

**EDACS® Trunked Mobile Radio Test Software**  
**HP 11807A,E Option 011 Software**  
*User's Guide*  
**for the HP 8920A,D**

**HP Part No. 11807-90126**  
**Printed in U. S. A.**  
**January 1995**

EDACS® is a U.S. Registered trademark of Ericsson GE Mobile Communications

**Rev A**

Copyright © Hewlett-Packard Company 1995

**RESTRICTED  
RIGHTS LEGEND**

Use, duplication or disclosure by the U.S. Government is subject to restrictions as set forth in subparagraph (c) (1) (ii) of the Rights in Technical Data and Computer Software clause in DFARS 252.227-7013.

Hewlett-Packard Company  
3000 Hanover Street  
Palo Alto, CA 94304  
U.S.A.

Rights for non- DOD U.S. Government Departments and Agencies are as set forth in FAR 52.227-19 (c) (1, 2).

---

## Contents

### **1 Getting Started with FW Above Rev. A.14.00**

What You Will Test 19

OVERVIEW 20

HOW TO USE THIS MANUAL 21

A. POWER-ON AND SET UP THE HP 8920A 22

B. DISPLAY AND SELECT FROM THE LIST OF TEST PROCEDURES AVAILABLE ON THE MEMORY CARD 24

Visual Reference Only: 25

C. RUN THE AUTOTEST PROCEDURE 26

C1. CONNECT THE CABLES AND POWER-UP THE RADIO 27

D. LOAD THE CHANNEL#s & FREQUENCIES  
Frequencies shown are for example only! 28

Visual Reference Only 29

E. SET THE AUDIO LEVEL AND IMPEDANCE  
Assumes 8 Ohms @ 2 Watts, for example only! 30

VISUAL REFERENCE ONLY 31

F. SET CHAN#s, GROUP ID, LOGICAL ID, SITE ID 32

Visual Reference Only 33

G. AUTOTESTING THE EDACS RADIO 34

AUTOTESTING THE RADIO 35

H. AUTOTESTING STOPPED ON A FAILURE 36

---

## Contents

J. IF YOU HAVE A PROBLEM 38

---

## Contents

### **2 Getting Started with FW Below Rev A.14.00**

What You Will Test 41

OVERVIEW 42

HOW TO USE THIS MANUAL 43

A. POWER-ON AND SET UP THE HP 8920A 44

B. DISPLAY AND SELECT FROM THE LIST OF TEST PROCEDURES AVAILABLE ON THE MEMORY CARD 46

Visual Reference Only: 47

C. RUN THE AUTOTEST PROCEDURE 48

C1. CONNECT THE CABLES AND POWER-UP THE RADIO 49

D. LOAD THE CHANNEL#s & FREQUENCIES Frequencies shown are for example only! 50

Visual Reference Only 51

E. SET THE AUDIO LEVEL AND IMPEDANCE Assumes 8 Ohms @ 2 Watts, for example only! 52

F. SET CHAN#s, GROUP ID, LOGICAL ID, SITE ID 54

Visual Reference Only 55

G. AUTOTESTING THE EDACS RADIO 56

AUTOTESTING THE RADIO 57

H. AUTOTESTING STOPPED ON A FAILURE 58

J. IF YOU HAVE A PROBLEM 60

---

## Contents

### **3 Product Description**

HP 11807A,E Software 62

Finding the Information You Need 66

Additional Services Available 67

---

## Contents

### **4 Making Connections**

What You Should Know Before Making Connections 70

---

## Contents

	<b>5</b>	<b>Using the Software/HP 8920B, or HP 8920A FW Above Rev.</b>	
<b>A.14.00</b>			
		Firmware Enhancements	76
		Testing Overview	79
		Customizing Testing	84



---

## Contents

### **6 Using the Software/HP 8920A FW Rev. Below A.14.00**

Firmware Enhancements 111

What You Should Know Before Using the Software 112

Testing Overview 113

Running Tests 115

Customizing Testing 120

<b>tions</b>	<b>7 Test, Parameter, and Pass/Fail Limit (Specification) Descriptions</b>
	148
	Test_01: TX and RX stand-by current drain 153
	Test_02: TX frequency error 155
	Test_03: TX output power 156
	Test_04: TX modulation limiting 158
	Test_05: TX audio frequency response 160
	Test_06: TX audio distortion 163
	Test_07: TX microphone sensitivity 165
	Test_08: TX FM hum and noise 167
	Test_09: TX residual AM hum and noise 169
	Test_10: TX signaling deviation & freq/code 171
	Test_11: RX hum and noise 173
	Test_12: RX audio distortion 175
	Test_13: RX frequency response 177
	Test_14: RX usable sensitivity 180
	Test_15: RX conv audio squelch sensitivity 182
	Test_16: RX conv squelch blocking 184
	Test_17: RX squelch opening with signaling 186
	Test_18: RX audio sensitivity 188

---

## Contents

Test_19: RX conv signal displacement bw	190
Test_20: RX quick test	192
Test_21: TX quick test	196
Test_22: RT manual test	200
Test_23: TX transient frequency behavior	204
Parameters	206
Pass/Fail Limits (Specifications)	214

### **8 Reference (Alphabetical)**

Conventions Used 222

Channel Information (Frequencies) 223

Copying Files 230

Data Collection (Saving and Retrieving Test Results) 232

Disks 241

Exiting a Program 244

HP-IB Control Annunciators 245

Memory Cards 246

Parameters 252

Pass/Fail Limits (specifications) 254

Pausing or Stopping a TEST 256

Printing 257

Procedures 269

RAM Disk 275

Saving Tests Results 278

Serial Port 279

Test Execution Conditions 281

USER Keys 283

---

## Contents

### **9 Problem Solving**

Data-Collection Function Does Not Work 287

Establishing a Trunked Transmit or Receive Channel 289

Memory Space Problems 290

Printing Problems 292

Program was Incorrectly Loaded 294

Radio Drastically Fails One or More Tests 296

Radio Fails CTCSS/CDCSS Tests 298

Radio Volume Can't Be Set When the Meter is Displayed 299

Test Procedure Doesn't Run on Your HP 8920A,D 300

Test Set Doesn't Power Up 301

Transmitter Isn't Keying 302

---

## Contents

Glossary 305

---

## Contents

**Index 309**

---

## Contents



---

**Getting Started with FW Above Rev.  
A.14.00**



---

## What You Will Test

**NOTE:**

The firmware revision A.14.00 in the HP 8920A,D had several enhancements, which are standard in the HP 8920B. This chapter applies to users with:

- **HP 8920A test sets with firmware revision above A.14.00**
- **All HP 8920B test sets.**

The test set's firmware revision is displayed on the top right corner of the configuration screen.

- Press SHIFT CONFIG to display the configuration screen and read the firmware revision.

If you have an HP 8920A test set with firmware revision below A.14.00, refer to [chapter 2, "Getting Started with FW Below Rev A.14.00," on page 39](#).

Contact Hewlett-Packard at 1-800-922-8920 for details on upgrading your firmware if desired.

---

Five minutes with the *Getting Started Guide* will steer you through autotesting the Ericsson GE EDACS radio. You will learn, hands-on, how to use the HP 8920A and the HP 11807A,E Option 011 software to align and test conventional and trunked mobile radios. This guide will prepare you to use the *HP 8920A User's Guide* and the remainder of the *HP 11807A,E Option 011 Software User's Guide* which provides detail. The *Getting Started Guide* includes a troubleshooting guide.

## OVERVIEW

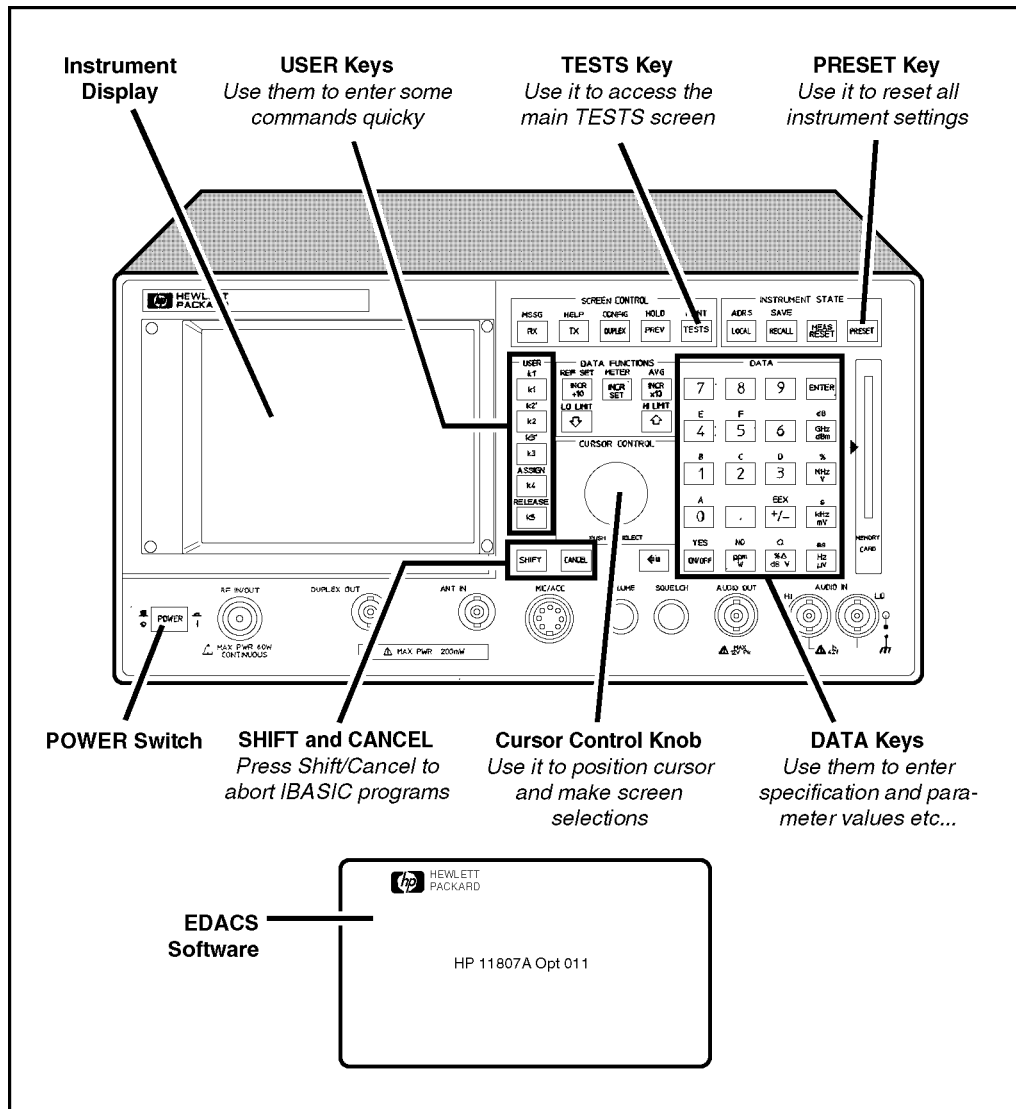

OVERVIEW1

## HOW TO USE THIS MANUAL

Most of the instructions in this guide are presented as two page modules each designed to guide you through a complete task. On some modules you need perform the steps on the left hand page only and use the right hand page for reference. In these cases the right hand page will be marked **For Visual Reference Only**. Other modules will require that you perform the steps on both pages.

<p><b>Step Number</b> Indicates the sequential order of the steps to be performed.</p>	<p><b>Step number locator</b> Points to the area on the screen where the step is performed.</p>	<p><b>Screen Name</b> Identifies the screen that is present on your display.</p>	<p><b>For Visual Reference Only</b> Indicates that the graphic in the box is to be used as a visual aid only.</p>
<div data-bbox="329 940 828 1619"> <p><b>Follow Numbered Steps</b> Use the cursor control knob on front panel to position the cursor and make selections.</p> <p><b>Use figure on opposite page for reference.</b></p> <p><b>1</b> Note: cursor is positioned at <b>Select Procedure Location.</b></p> <p>Select Procedure Location:</p> <p>(If previous entries appear disregard them)</p> <p><b>2</b> Press knob to select <b>Select Procedure Location.</b></p> <p><b>3</b> Position cursor at <b>Card</b> and select it.</p> <p><b>4</b> Position cursor at <b>Select Procedure File...</b> and select it.</p> <p><b>5</b> Position cursor at <b>Full</b> and select it.</p> <p>Next: Turn page to load software</p> <p><b>LEFT HAND PAGE</b></p> </div>		<div data-bbox="828 940 1352 1619"> <p><b>TESTS (Main Menu) Screen</b></p> <p><b>For Reference Only</b></p> <p>TESTS (Main Menu)</p> <p>Please select a procedure to load.</p> <p><b>2</b> <b>LOAD TEST PROCEDURE!</b></p> <p><b>4</b> Select Procedure Location:</p> <p>Select Procedure Filename: Library: Program:</p> <p>Description:</p> <p><b>3</b> Choice:</p> <p><b>5</b> Card ROM Disk</p> <p><b>CHANS</b></p> <p><b>FULL</b></p> <p><b>MANUAL</b></p> <p><b>NB_CHAN</b></p> <p><b>NB_FULL</b></p> <p><b>NB_MANL</b></p> <p><b>RIGHT HAND PAGE</b></p> </div>	

MANUSE1a

## A. POWER-ON AND SET UP THE HP 8920A

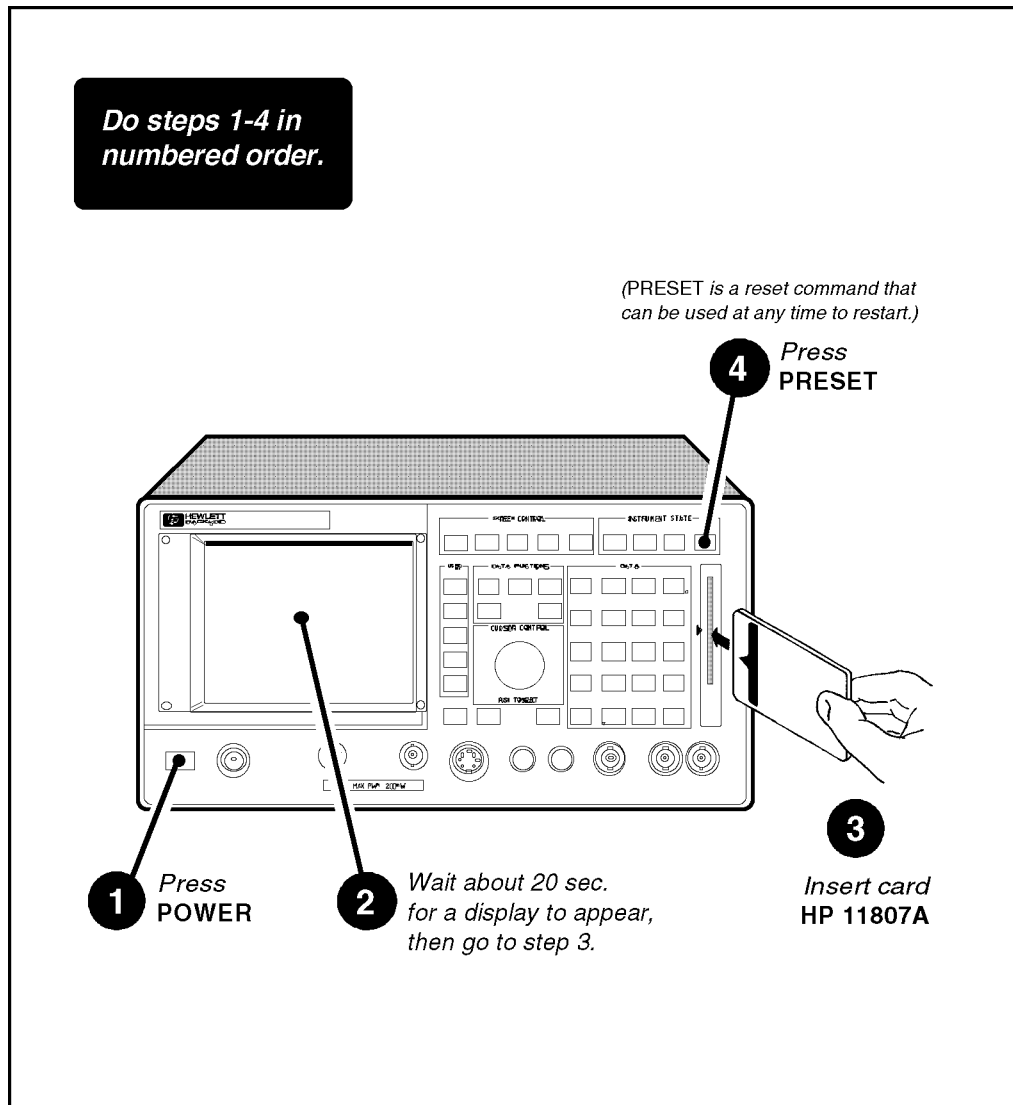

LOAD1

Continue on next page

When you see this screen, turn the page and continue.

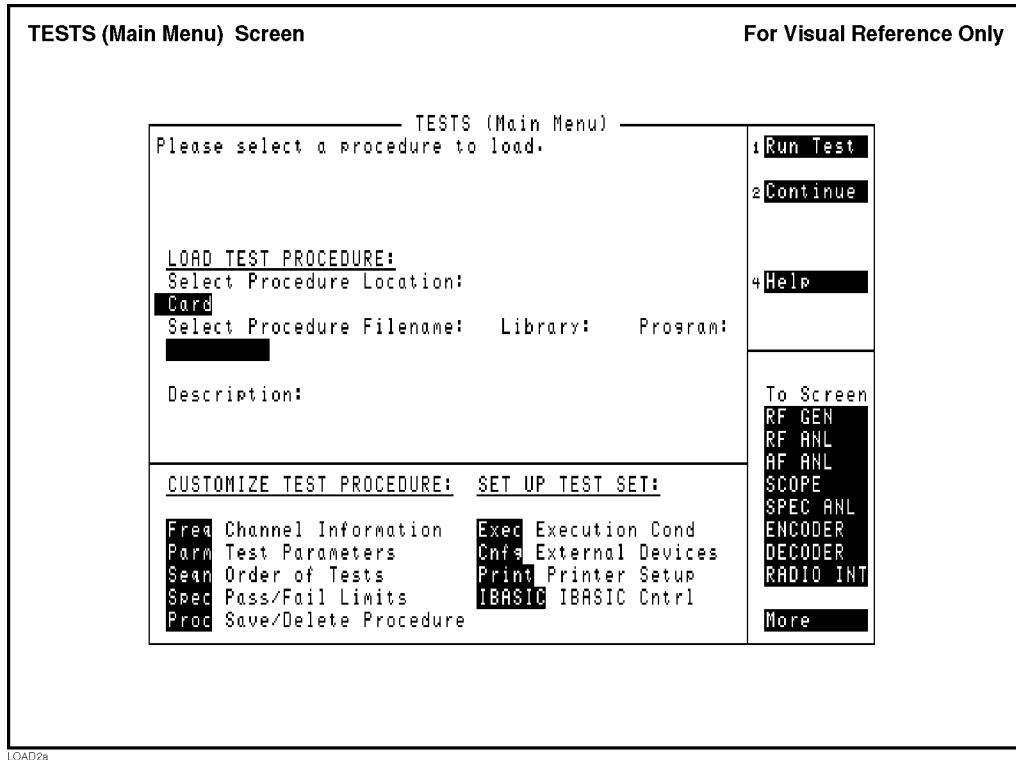

Figure 1

Chapter 1  
Getting Started with FW  
Above REV. A.14.00

**B. DISPLAY AND SELECT FROM THE LIST OF TEST PROCEDURES AVAILABLE ON THE MEMORY CARD**

**B. DISPLAY AND SELECT FROM THE LIST OF TEST PROCEDURES AVAILABLE ON THE MEMORY CARD**

**Follow Numbered Steps**

Use the cursor control knob on front panel to position the cursor and make selections.

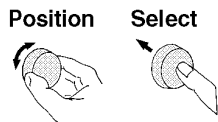

**Use figure on opposite page for reference.**

**1** Note; cursor is positioned at **Select Procedure Location.**

Select Procedure Location:

(If previous entries appear disregard them)

**2** Press knob to select **Select Procedure Location.**

**Select**

Select Procedure Location:

**3** Position cursor at **Card** and select it.

**Position**

**Select**

Choices :

- Card
- ROM
- RAM
- Disk

**4** Position cursor at **Select Procedure File...** and select it.

**Position**

**Select**

Select Procedure Filename:

**5** Position cursor at **FULL** and select it.

**Position**

**Select**

Choices :

- CHANS
- FULL
- MANUAL
- NB\_CHAN
- NB\_FULL
- NB\_MANL

PROCED1a

Next: Turn page to load FULL software





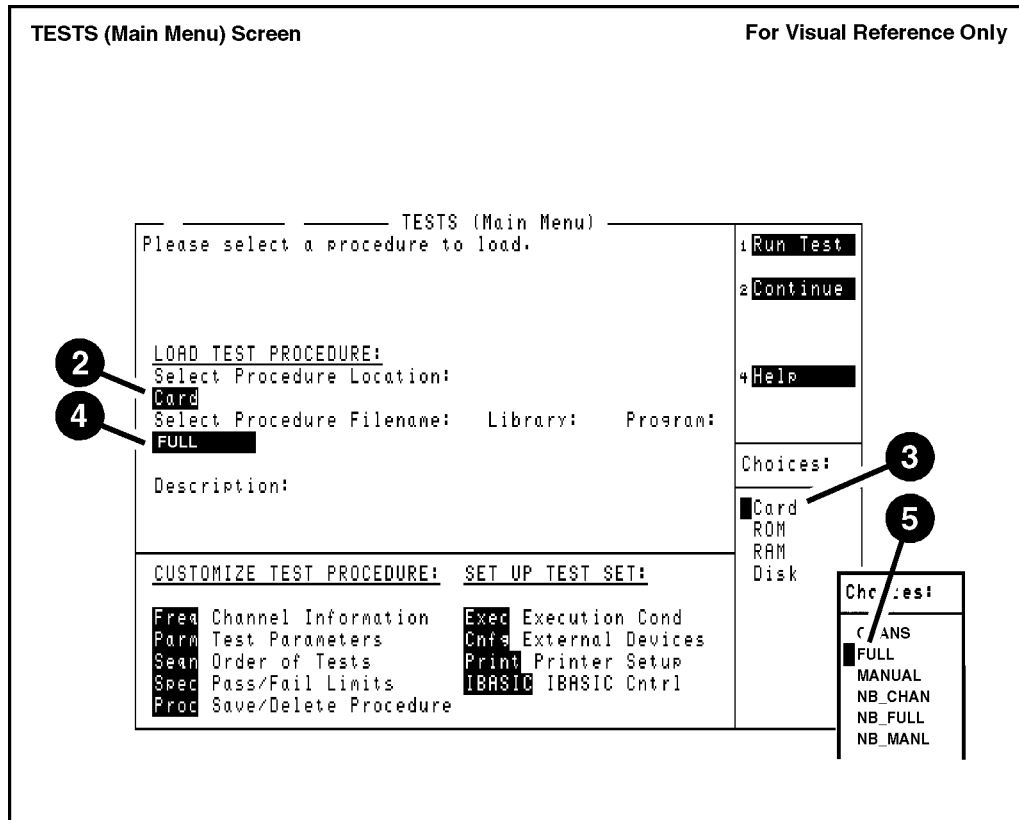



Visual Reference Only:



PROCEED 2a

Figure 2

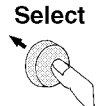
## C. RUN THE AUTOTEST PROCEDURE

<p><b>1</b> Position cursor at <b>Exec</b> Execution Cond and select it.</p> <p><b>Position</b></p>  <p><b>Select</b></p>  <table border="1" data-bbox="414 682 755 808"> <tr><td>Exec</td><td>Execution Cond</td></tr> <tr><td>Cnfg</td><td>External Devices</td></tr> <tr><td>Print</td><td>Printer Setup</td></tr> <tr><td>IBASIC</td><td>IBASIC Cntrl</td></tr> </table>	Exec	Execution Cond	Cnfg	External Devices	Print	Printer Setup	IBASIC	IBASIC Cntrl	<p><b>2</b> Position cursor at <b>If Unit Under Test ...</b> and select <b>Stop</b>.</p> <p><b>Position</b></p>  <p><b>Select</b></p>  <p>If Unit Under Test Fails:</p> <table border="1" data-bbox="950 703 1128 745"> <tr><td>Continue/Stop</td></tr> </table> <p>(The underline indicates which option is selected. Pressing the knob changes the selection.)</p>	Continue/Stop
Exec	Execution Cond									
Cnfg	External Devices									
Print	Printer Setup									
IBASIC	IBASIC Cntrl									
Continue/Stop										
<p>Selecting <b>Stop</b> sets the HP 8920A/E to stop on failures detected during testing. Selecting this option allows you to make adjustments as failures occur.</p>	<p><b>3</b> Position cursor at <b>Run Test</b> and select it.</p> <p><b>Position</b></p>  <p><b>Select</b></p>  <p>Loading software takes 2 min. using an HP 8920A and 15 sec. using a HP 8920B.</p>  <table border="1" data-bbox="1112 1018 1258 1228"> <tr><td>Run Test</td></tr> <tr><td>2 Continue</td></tr> <tr><td>4 Help</td></tr> </table>	Run Test	2 Continue	4 Help						
Run Test										
2 Continue										
4 Help										
<p><b>4</b> Make necessary connections to your radio.</p> <p>While <b>FULL</b> procedure is loading, use diagram on next page to make necessary connections to your radio.</p>	<p><b>5</b> When choices below appear, turn to next page.</p> <p>= =&gt; Trunked radio          Conventional Radio</p>									

RUN1a

Next: Turn page to Load the Channel#s and Frequencies

## C1. CONNECT THE CABLES AND POWER-UP THE RADIO

### Hardware Configuration

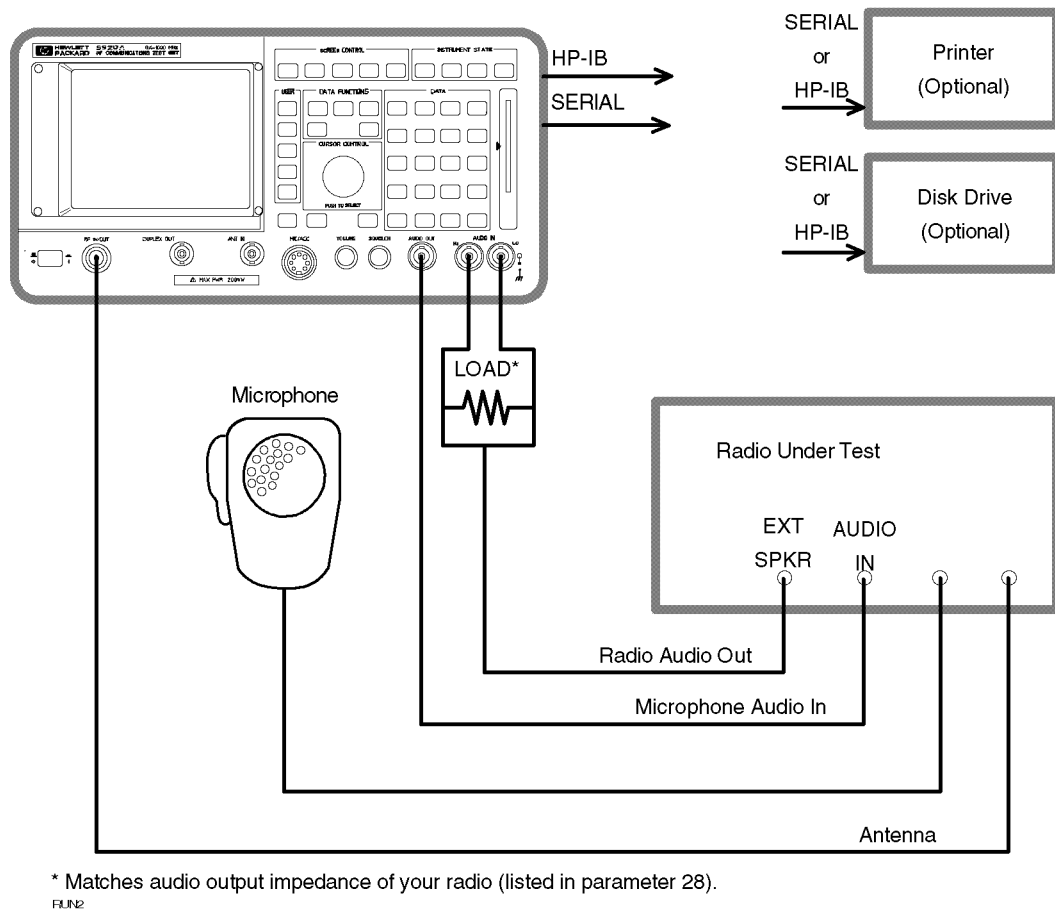
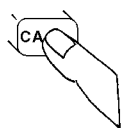
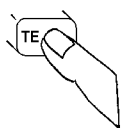



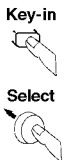
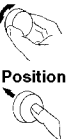

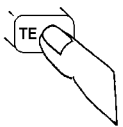

Figure 3

**D. LOAD THE CHANNEL#s & FREQUENCIES** Frequencies shown are for example only!

**D. LOAD THE CHANNEL#s & FREQUENCIES**  
Frequencies shown are for example only!

<p><b>1</b> Press <b>CANCEL</b> to pause any IBASIC code that is running.</p> 	<p><b>2</b> Press <b>TESTS</b> to display TESTS (Main Menu) screen.</p> 	<p><b>3</b> Position cursor at <b>Freq</b> Pass Fail Limits and select it.</p> <p><b>Position</b></p> <ul style="list-style-type: none"> <li><input checked="" type="checkbox"/> Freq Channel Information</li> <li><input type="checkbox"/> Parm Test Parameters</li> <li><input type="checkbox"/> Seqn Order of Tests</li> <li><input type="checkbox"/> Spec Pass Fail Limits</li> <li><input type="checkbox"/> Proc Save/Delete Procedure</li> </ul> <p><b>Select</b></p> 
<p><b>4</b> Note; new screen is present on your display.</p> <p>The Pass/Fail Limits screen is now present on your CRT.</p>	<p><b>5</b> Select, scroll to <b>Chan# 1</b>, then select again.</p> <p><b>Select</b></p> <p><b>Scroll</b></p>  <p>1 857.825000 8 (Control Channel)</p>	<p><b>6</b> Position cursor as shown, key-in correct RX Freq, then select it.</p> <p><b>Position</b></p> <p>(Use DATA keypad to key-in correct value)</p> <p><b>Key-in</b></p>  <p>1 123.456789 812</p>
<p><b>7</b> Position cursor as shown below.</p> <p><b>Select</b></p> <p><b>Position</b></p>  <p>123.456789 812.825000</p>	<p><b>8</b> Key-in correct TX frequency, then select it.</p> <p><b>Key-in</b></p> <p><b>Select</b></p>  <p>123.456789 123.456789 (Use DATA keypad to key-in correct value)</p>	<p><b>9</b> Position cursor at each field below and position underline to <b>No</b>.</p> <p><b>Position</b></p> <p><b>Position</b></p>  <p>Yes/No Yes/No (To position line, press knob)</p>
<p><b>10</b> Position cursor at <b>Chan#</b> field and repeat steps 5-8 for Chan# 2. Set Test? and Prime? to Yes.</p> <p><b>Position</b></p>  <p>2 857.825000 812.825000 Yes/No Yes/No (Working Channel)</p>	<p><b>11</b> Press <b>TESTS</b> to display the TESTS (Main Menu) screen.</p> 	

FRQCHN1a

Next: Turn page to Set the Audio Level and Impedance

Visual Reference Only

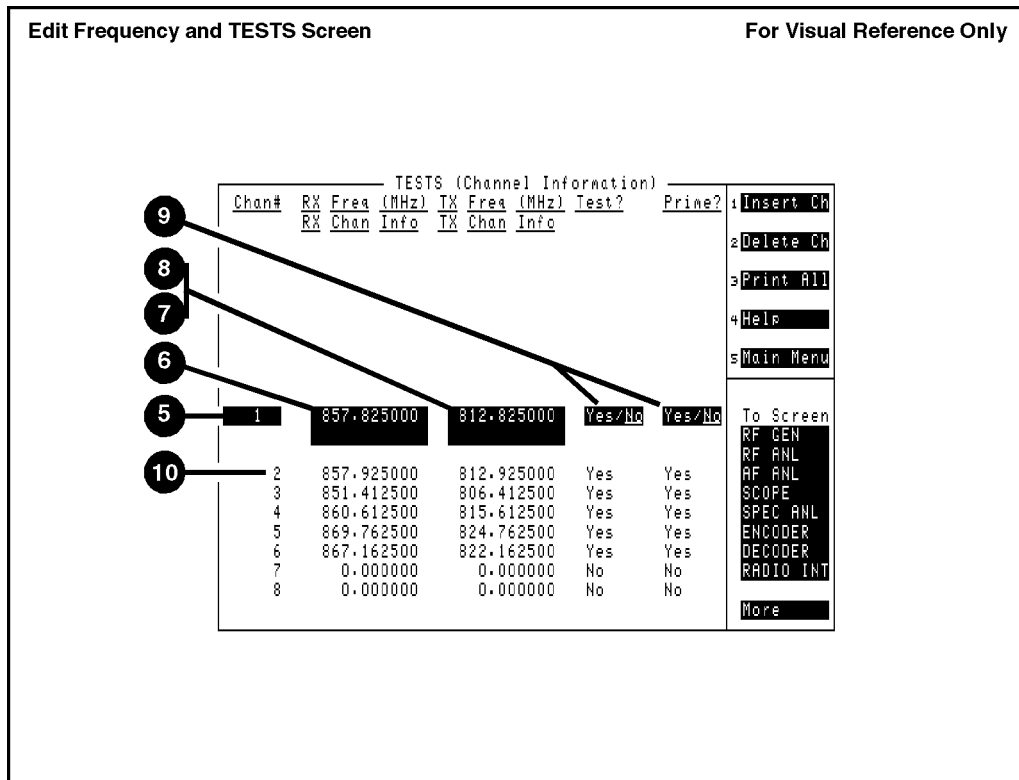
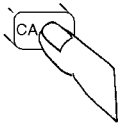
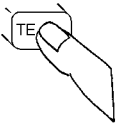













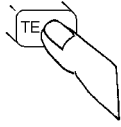



Figure 4

**E. SET THE AUDIO LEVEL AND IMPEDANCE Assumes 8 Ohms @ 2 Watts, for example only!**

**E. SET THE AUDIO LEVEL AND IMPEDANCE**  
**Assumes 8 Ohms @ 2 Watts, for example only!**

<p><b>1</b> Press <b>CANCEL</b> to pause any IBASIC code that is running.</p> 	<p><b>2</b> Press <b>TESTS</b> to display the TESTS (Main Menu) screen.</p> 	<p><b>3</b> Position cursor at <b>[Parm] Test Parameters</b> and select it.</p> <p><b>Position</b>   <ul style="list-style-type: none"> <li>Freq Channel Information</li> <li><b>Parm</b> Test Parameters</li> <li>Seqn Order of Tests</li> <li>Spec Pass Fail Limits</li> <li>Proc Save/Delete Procedure</li> </ul> <p><b>Select</b>  </p> </p>
<p><b>4</b> Note; new screen is present on your display.</p> <p>The Test Parameters screen is now present on your CRT.</p>	<p><b>5</b> Position cursor at <b>Parm#</b> field and select it.</p> <p><b>Position</b>   (Entries on your display may be different.)</p> <p><b>Select</b>   <b>1</b> AA use GN valu  <span style="border: 1px solid black; padding: 2px;">4.000000</span></p>	<p><b>6</b> Rotate knob to scroll to <b>RX audio load...</b>, and select it.</p> <p><b>Rotate</b>   (This parameter number is subject to change.)</p> <p><b>Select</b>   <b>30</b> RX audio load impe  <span style="border: 1px solid black; padding: 2px;">4.000000</span> Ohms</p>
<p><b>7</b> Position cursor at <b>Value</b> field, key in the value, then select it.</p> <p><b>Position</b>   (Use <b>DATA</b> keypad to key in new value.)</p> <p><b>key in</b>   <b>30</b> RX audio load impe  <span style="border: 1px solid black; padding: 2px;">8.000000</span> Ohms</p>	<p><b>8</b> Position cursor at <b>Parm#</b> field and select it.</p> <p><b>Position</b>   <b>30</b> RX audio load imp</p> <p><b>Select</b>   <span style="border: 1px solid black; padding: 2px;">8.000000</span> Ohms</p>	<p><b>9</b> Rotate knob to scroll to <b>RX audio maxim...</b>, and select it.</p> <p><b>Rotate</b>   <b>31</b> RX audio maximum</p> <p><b>Select</b>   <span style="border: 1px solid black; padding: 2px;">1.000000</span> Watts</p>
<p><b>10</b> Position cursor at <b>Value</b> field, key in the value, then select it.</p> <p><b>Position</b>   (Use <b>DATA</b> keypad to key in new value.)</p> <p><b>key in</b>   <b>31</b> RX audio maximum  <span style="border: 1px solid black; padding: 2px;">2.000000</span> Watts</p>	<p><b>11</b> Press <b>TESTS</b> to display the TESTS (Main Menu) screen.</p> 	<p><b>12</b> Position cursor at <b>Run Test</b> and select it.</p> <p><b>Position</b>   <b>Run Test</b></p> <p><b>Select</b>   <span style="border: 1px solid black; padding: 2px;">2 Continue</span></p> <p><span style="border: 1px solid black; padding: 2px;">4 Help</span></p>

GSPARM1a





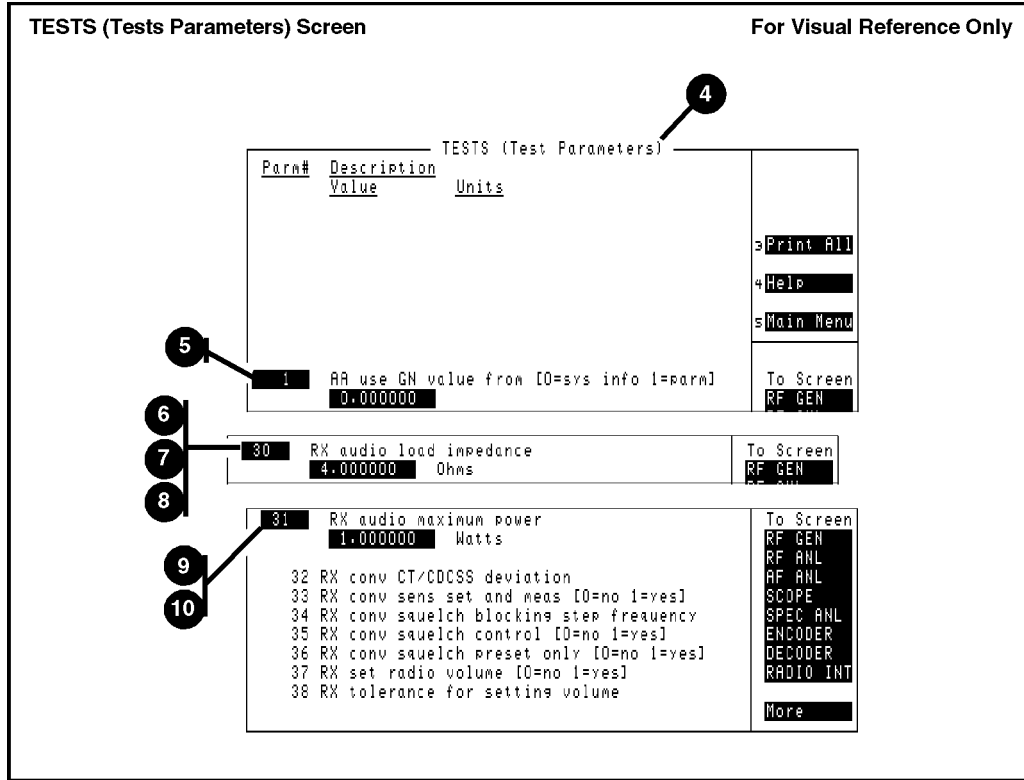





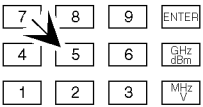

Next: Turn page to Set Chan #s, Group ID, Logical ID and Site ID.

**VISUAL REFERENCE ONLY**

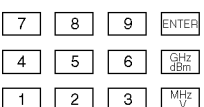

**Figure 5**

**F. SET CHAN#s, GROUP ID, LOGICAL ID, SITE ID**

<p><b>1</b> Position arrow at <b>Trunked radio</b> and select it.</p> <p><b>Position</b>            ==&gt;Trunked radio          Conventional Radio</p> <p><b>Select</b>  </p>	<p><b>2</b> Position arrow at <b>Working Channel</b> and select it.</p> <p><b>Position</b>            ==&gt;Working channel : 5          Control channel : 1          Group ID : 2035          Logical ID : 4095          Site ID : 1          Call Type :Group          Callee ID (Indv Call) :4093</p> <p><b>Select</b>  </p>	<p><b>3</b> Press 5 on <b>DATA</b> keypad, then select it.</p> <p><b>Press</b>            DATA  </p> <p><b>Select</b>  </p>
<p><b>4</b> Position arrow at <b>Group ID</b> and select it.</p> <p><b>Position</b>            Begin testing : 5          Working channel : 5          Control channel : 1          ==&gt; Group ID : 2035          Logical ID : 4095          Site ID : 1          Call Type :Group          Callee ID (Indv Call) :4093</p> <p><b>Select</b>  </p>	<p><b>5</b> Key-in appropriate <b>Group ID</b>, then select it.</p> <p><b>Key-in</b>            DATA  </p> <p><b>Select</b>  </p>	<p><b>6</b> If required, repeat steps 4 and 5 for other setting.</p> <p><b>Change if required</b>            Begin testing : 5          Working channel : 5          Control channel : 1          Group ID : 2035          Logical ID : 4095          Site ID : 1          Call Type :Group          Callee ID (Indv Call) :4093</p>
<p><b>7</b> Confirm all settings are correct, then go to step 8.</p> <p><b>Note</b>          If you need to make changes to frequency settings, go to <b>Task D. LOAD CHAN#s.</b></p>	<p><b>8</b> Position arrow at <b>Begin testing</b> and select it.</p> <p><b>Position</b>            ==&gt;Begin testing : 5          Working channel : 5          Control channel : 1          Group ID : 2035          Logical ID : 4095          Site ID : 1          Call Type :Group          Callee ID (Indv Call) :4093</p> <p><b>Select</b>  </p>	<p><b>Turn page to continue.</b></p>

SY5INF01

Next: Turn page to begin Autotesting the EDACS Radio



Visual Reference Only

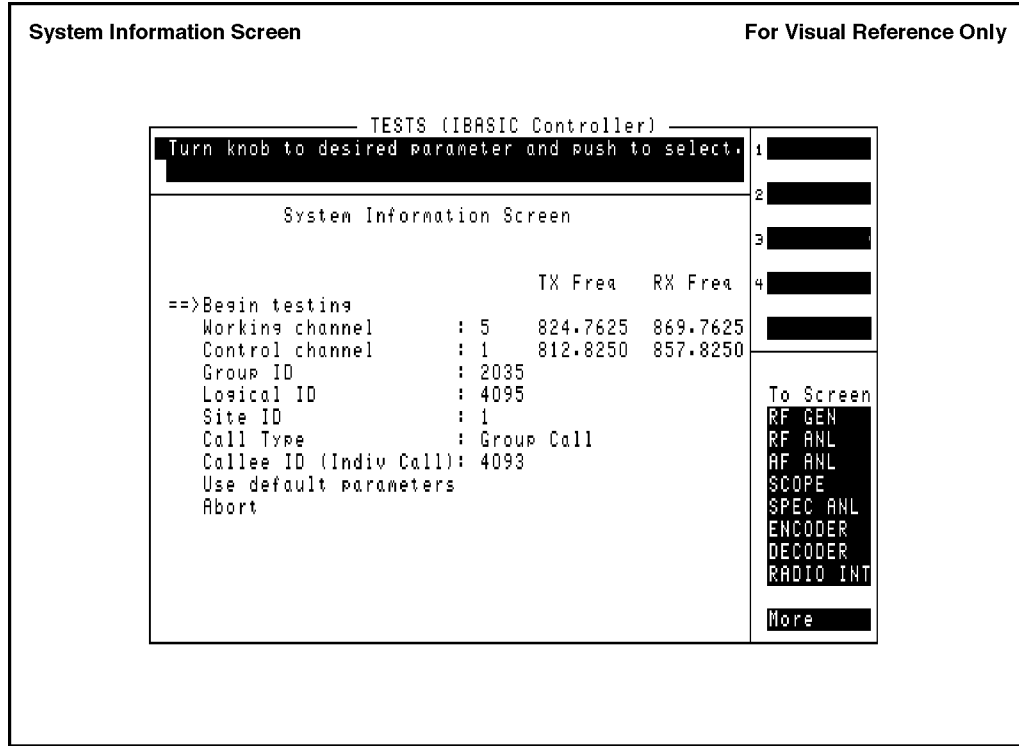



SY5INFO2

Figure 6

G. AUTOTESTING THE EDACS RADIO

G. AUTOTESTING THE EDACS RADIO

**1** On next three screens, do instructions in highlighted box at top of screen, then position cursor at **Continue** and select it.

**Position**  **Select** 

**1A** → **TESTS (IBASIC Controller)**  
 Verify transmitter is de-keyed. Press Continue.



**1B** → **TESTS (IBASIC Controller)**  
 Set radio to the system programmed with Trunked  
 Chan 2: RX=857.925 MHz; TX=812.925 MHz

**1C** → **TESTS (IBASIC Controller)**  
 Set radio VOLUME to maximum. Press Continue.

Performs quick tests on one channel for radios with EDACS trunked and/or conventional FM channels

Test conditions	Measured value	P/F
-----Chan=5: RX=869.7625 MHz; TX=824.7625 MHz-----		

**2** On next three screens, adjust volume until indicator resides between large graticules on meter; program will proceed automatically.

**Position**  **Select** 

**2A** → **TESTS (IBASIC Controller)**  
 \* \* \*Set radio\* \* \*  
 VOLUME

**2B** → **TESTS (IBASIC Controller)**  
 \* \* \*Set radio\* \* \*  
 VOLUME

**2C** → **TESTS (IBASIC Controller)**  
 \* \* \*Set radio\* \* \*  
 VOLUME

**Note**  
 If you are unable to set volume within graticules, adjust it as close as possible, then position cursor at **Take It** and select it.

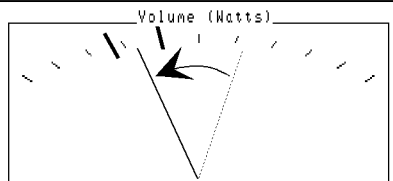

1 Take It
2 Not Set
3
4
5

To Screen  
 RF GEN  
 RF PAU

Next: Continue on the next page

## AUTOTESTING THE RADIO

- 3** To proceed through remaining test screens, follow instructions displayed in highlighted box at top of screen.

Follow instructions in this box

```

    TESTS (IBASIC Controller)
    -----
    Performs quick tests on one channel for radios
    with EDACS trunked and/or conventional FM channels
    =====
    Test conditions           Measured value   P/F
    =====
    -----Chan 5: RX=869.7625 MHz: TX=824.7625 MHz-----
    -----Call type = Group Call-----
    RX audio sen @40% rated dev   0.0 Watts
    RX audio distn 17 dB down     92.9 %
    RX audio distortion           96.9 %
    RX SINAD @ .2 uV             1.5 dB
    RX hum & noise unswelched    -5.5 dB
    RX audio resp @ .30 kHz      -10.7 dB error
    RX audio resp @ .80 kHz      -1.7 dB error
    RX audio resp @ 1.30 kHz     2.2 dB error
    RX audio resp @ 1.80 kHz     5.3 dB error
    RX audio resp @ 2.30 kHz     2.2 dB error
    =====
    
```

If F appears in this column, program has Stopped on Failure; go to Task H.

- 4** When test results are displayed at bottom of screen, testing has finished and cabling may be disconnected.

Verify test results here

```

    TESTS (IBASIC Controller)
    -----
    RX audio distn 17 dB down     4.6 %
    RX audio distortion           5.0 %
    RX SINAD @ .2 uV             11.4 dB
    RX hum & noise unswelched    29.6 dB
    RX audio resp @ .30 kHz      -2.0 dB error
    RX audio resp @ .80 kHz      .4 dB error
    RX audio resp @ 1.30 kHz     -.8 dB error
    RX audio resp @ 1.80 kHz     -2.1 dB error
    RX audio resp @ 2.30 kHz     -2.9 dB error
    RX audio resp @ 2.80 kHz     -4.3 dB error
    RX audio resp @ 3.00 kHz     -4.4 dB error
    RX trunking opening:
    RX SINAD @ .3 uV             20.3 dB
    -----
    Points passed= 13: Points failed= 1
    Test time= 250 secs.
    -----
    
```

1 Run  
 2 Continue  
 3 Sngl Step  
 4 Clr Scr

To Screen  
 RF GEN  
 RF ANL  
 AF ANL  
 SCOPE  
 SPEC ANL  
 ENCODER  
 DECODER  
 RADIO INT  
 More

FULLTST2

---

## H. AUTOTESTING STOPPED ON A FAILURE

*The program has stopped and you see an F in the P/F column. NOW WHAT?*

There are several ways to proceed:

- a. The screen will prompt “Press Continue when ready”. Position the cursor and select “Continue”. Troubleshooting to the component level may be necessary.
- b. Before repairing the radio consider these additional sources of the failure:
  - i. Are all cables connected properly?
  - ii. Have you followed all alignment, cabling, and setup procedures?
  - iii. Verify the pass/fail limits and parameters in **chapter 7**, in the *HP 11807A,E Opt 011 Software User’s Guide*.
  - iv. Confirm all frequencies, ID#,s, Channel#,s, and parameters in Tasks D, E, and F.
- c. Is the HP 8920A working properly? The HP 8920A has a self-test, see the *HP 8920A,B User’s Guide*.

## I. TROUBLE CHECK

Task	Symptom	Cause	Corrective Action	Ref
A	Power doesn't turn ON	Line cord not attached	Attach line cord	<sup>1</sup>
		HP 8920A warm-up delay	Wait 20 seconds	A
		AC/DC switch in wrong setting	Set AC/DC to AC	1
A-F	Wrong screen display	HP 8920A warm-up delay	Wait 20 secs; press PRESET	A
		Pressed knob while rotating	Repeat start-up sequence	A
		Rotated knob while pressing	Repeat start-up sequence	A
B-C	No Procedures, Error 80	Improperly inserted CARD	Orient & insert firmly	A
		Improper CARD	Verify HP 11807A,E Opt 011	A
G	'Audio level < 5% of max power	audio set too low	increase audio volume	6-11 <sup>2</sup>
		RX Handshake unsuccessful	Press K1: RX Hndshk	
		wrong frequencies	correct frequencies	task D
		improper ID #s	correct ID#s	task F
		improper cabling	correct cabling	Figure 3
G	Audio won't set	incorrect Parameters	Edit Parameters	6-11 <sup>2</sup>
A	Wrong screen on restart	Shows last screen until HP 8920A is finished thinking	Wait 20 seconds	1
		IBASIC is still running	Press CANCEL to pause IBASIC prior to TESTS or PRESET keys	1
G	Tests stopped, won't continue	Stopped on UUT failure	select Continue	H
G	Measurement failed spec	Incorrect p/f limit value	Edit p/f limit values	K & <sup>2</sup>
		Incorrect parameter value	Edit parameter values	L & <sup>2</sup>
		Faulty cabling	Repeat cabling instructions	Figure3
		Faulty radio	Repair/adjust radio	
G	Error message: 'No handshake with the UUT. Try again?'	Control Channel not responding	if you've gotten this far then it's probably radio insensitivity	2
		Control Chan drops out > 5 secs	restart Procedure: select CANCEL, TESTS, Run Test	A
		slight frequency inaccuracy	re-try several times	

1. HP 8920A User's Guide, Part Number 08920-90219; HP 8920B User's Guide, Part Number 08920-90221

2. HP 11807A,E Opt. 011 Software User's Guide, Part Number 11807-90126. See also [chapter 9](#) in the HP 11807A,E Software User's Guide.

**J. IF YOU HAVE A PROBLEM**

---

**J. IF YOU HAVE A PROBLEM**

**If you cannot find what you are looking for on the screen**

- Verify that the correct HP 8920A screen is displayed in each task.
- Corresponding correct reference screens are illustrated on the pages opposite tasks A, B, D, E, F, and G etc.
- The reference screens also indicate the position of required fields.
- , return to step #4, “PRESET” as shown in task A, and repeat all steps.
- Occasionally, displaying a final screen requires a 7 to 10 second wait for the screen to stabilize following a “select” function.
- Verify that the HP 11807A,E Option 011 memory card is inserted firmly and is in the proper orientation: task A.
- See also [chapter 9](#) in the *HP 11807A,E Option 011 Software User's Guide*

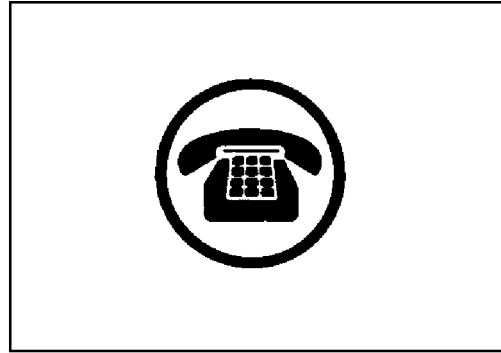
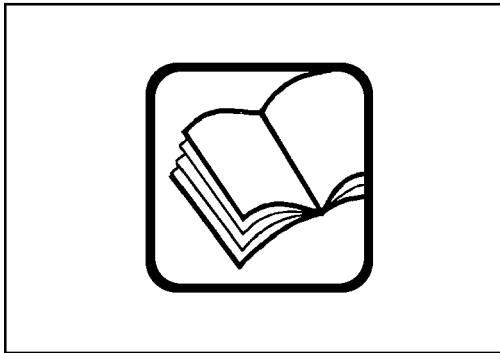

**IF YOU NEED ADDITIONAL HELP...**

Consult the HP 11807A,E Option 011 Software User's Guide or call the HP 8920A Hotline 1-800-922-8920 and give your software model number.

---

**Getting Started with FW Below Rev  
A.14.00**





---

## What You Will Test

**NOTE:** The firmware revision A.14.00 in the HP 8920A,D had several enhancements, which are standard in the HP 8920B. This chapter applies to users with:

- **HP 8920A test sets with firmware revision below A.14.00**

The test set's firmware revision is displayed on the top right corner of the configuration screen.

- Press SHIFT CONFIG to display the configuration screen and read the firmware revision.

If you have an HP 8920B or an HP 8920A with firmware revision above A.14.00, refer to . Contact Hewlett-Packard at 1-800-922-8920 for details on upgrading your firmware if desired.

---

Five minutes with the *Getting Started Guide* will steer you through autotesting the Ericsson GE EDACS radio. You will learn, hands-on, how to use the *HP 8920A* and the *HP 11807A Option 011* software to align and test conventional and trunked mobile radios. This guide will prepare you to use the *HP 8920A User's Guide* (HP Part Number 08920-90203) and the remainder of the *HP 11807A Option 011 Software User's Guide* (HP Part Number 11807-90126) which provide detail. The *Getting Started Guide* includes a troubleshooting guide.

**OVERVIEW**

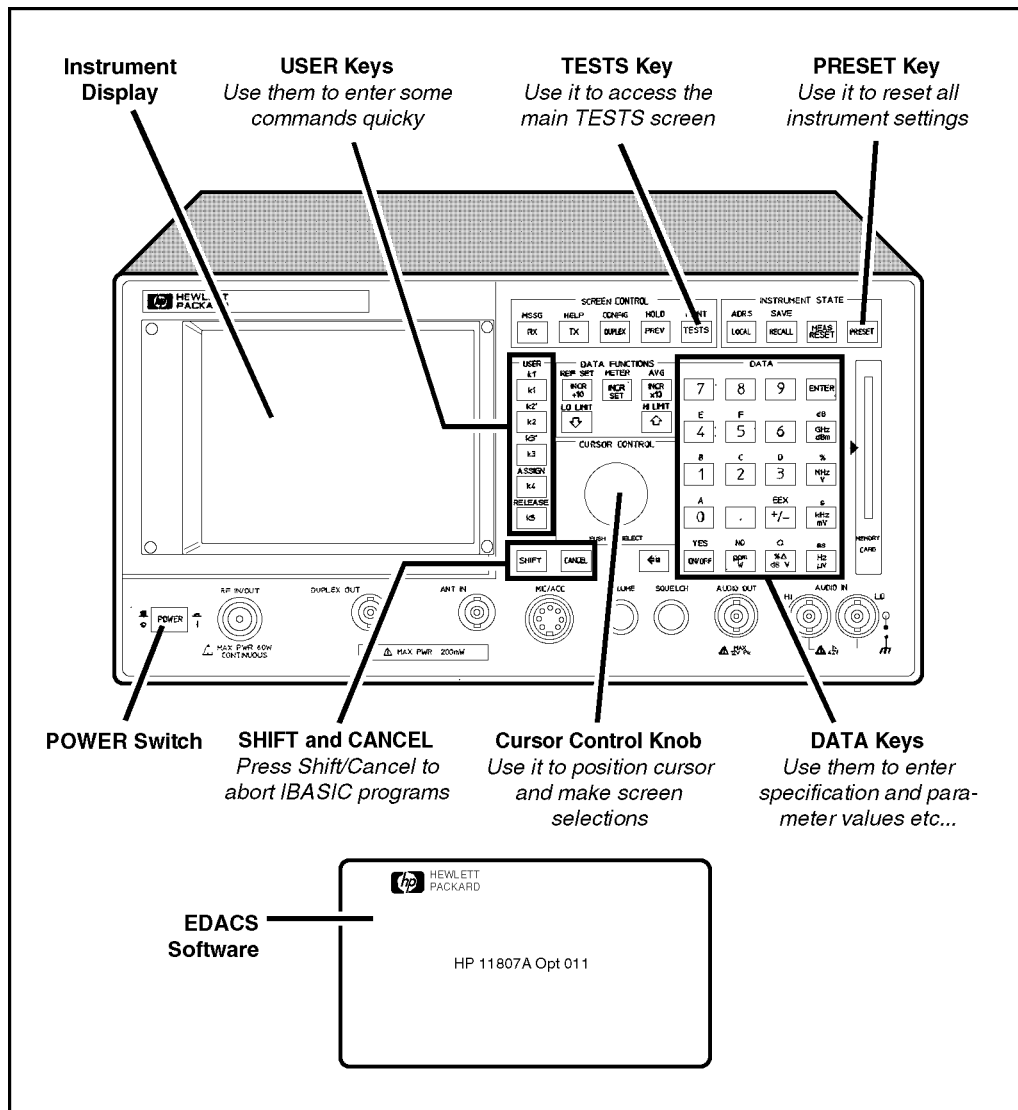

OVERVIEW1

## HOW TO USE THIS MANUAL

Most of the instructions in this guide are presented as two page modules each designed to guide you through a complete task. On some modules you need perform the steps on the left hand page only and use the right hand page for reference. In these cases the right hand page will be marked **For Visual Reference Only**. Other modules will require that you perform the steps on both pages.

**Step Number**  
Indicates the sequential order of the steps to be performed.

**Step number locator**  
Points to the area on the screen where the step is performed.

**Screen Name**  
Identifies the screen that should be present on your display.

**For Visual Reference Only**  
Indicates that the graphic in the box is to be used as a visual aid only.

**Follow Numbered Steps**  
Use the cursor control knob on front panel to position the cursor and make selections.

**Use figure on opposite page for reference.**

**1** Note cursor is positioned at Procedure.

Procedure: Location

(If previous entries appear disregard them)

**2** Position cursor at Location and select it.

Procedure: Location

**3** Position cursor at Card and select it.

Chooses:

Card  
ROM  
RAM  
Disk

**4** Position cursor at Procedure and select it.

Procedure: Location

Card

**5** Position cursor at FULL and select it.

Chooses:

CHANS  
FULL  
MANUAL  
NB\_CHAN  
NB\_FULL  
NB\_MANL

Next: Turn page to load FULL software

**LEFT HAND PAGE**

**For Visual Reference Only**

CSSTS Screen

**RIGHT HAND PAGE**

Chapter 2  
 Getting Started with FW Below  
 Rev. A.14.00

MANUSE1

A. POWER-ON AND SET UP THE HP 8920A

A. POWER-ON AND SET UP THE HP 8920A

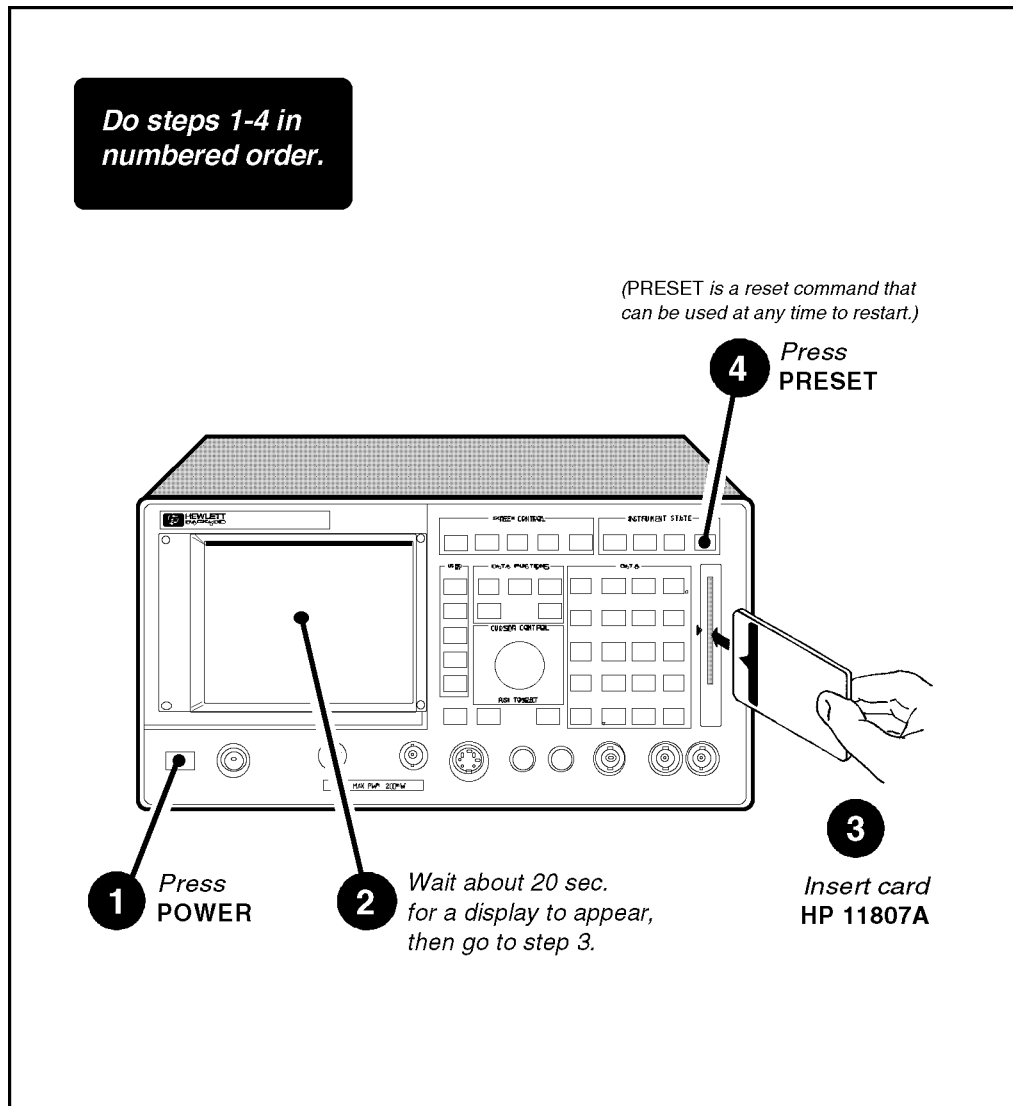

Continue on next page

When you see this screen, turn the page and continue.

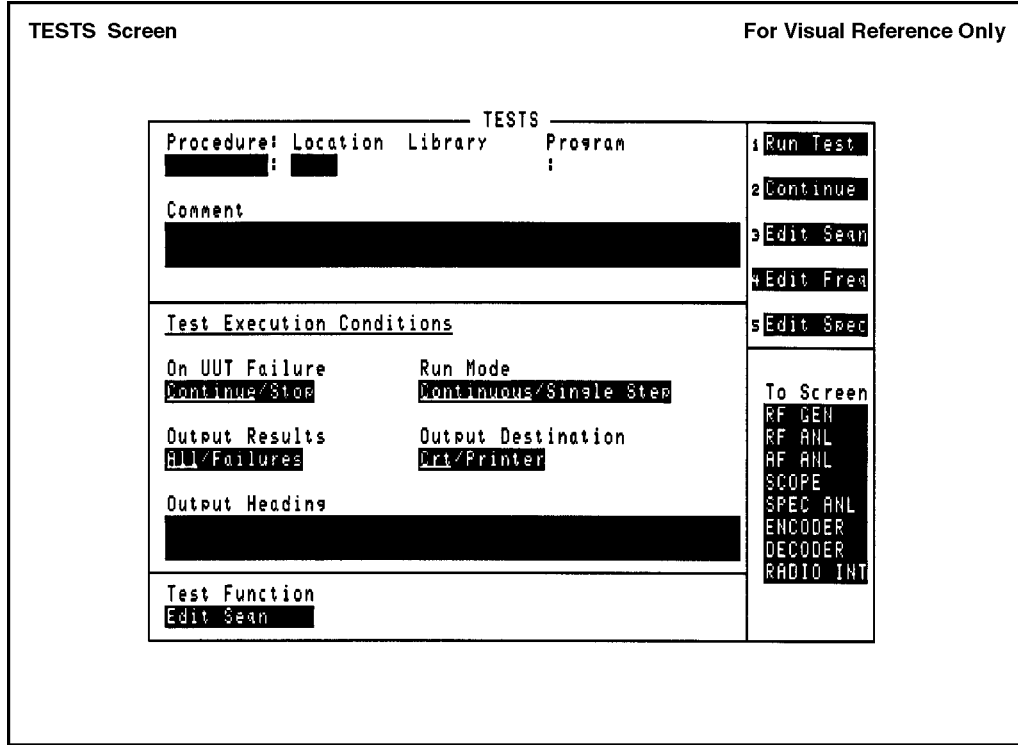
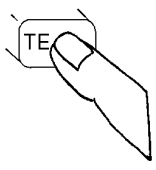
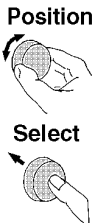
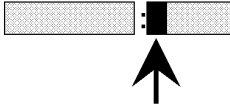
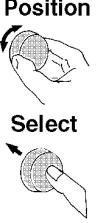

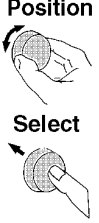

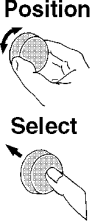

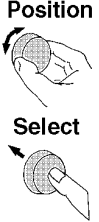



Figure 7

**B. DISPLAY AND SELECT FROM THE LIST OF TEST PROCEDURES AVAILABLE ON THE MEMORY CARD**

**B. DISPLAY AND SELECT FROM THE LIST OF TEST PROCEDURES AVAILABLE ON THE MEMORY CARD**

<p><b>5</b> Press <b>TESTS</b> to display the <b>TESTS</b> screen.</p> <p><i>If you are in <b>IBASIC</b>, press <b>SHIFT, CANCEL</b> before pressing <b>TESTS</b>.</i></p> 	<p><b>6</b> Position cursor at <b>Location</b> and select it.</p> <p><b>Position</b></p>  <p><b>Select</b></p> <p>Procedure: Location</p> 
<p><b>7</b> Position cursor at <b>Card</b> and select it.</p> <p><b>Position</b></p>  <p><b>Select</b></p>  <p>Choices :</p> <ul style="list-style-type: none"> <li>■ Card</li> <li>ROM</li> <li>RAM</li> <li>Disk</li> </ul>	<p><b>8</b> Position cursor at <b>Procedure</b> and select it.</p> <p><b>Position</b></p>  <p><b>Select</b></p>  <p>Procedure: Location</p> <p>■ : Card</p>
<p><b>9</b> Position cursor at the desired <b>Procedure</b> and select it.</p> <p><b>Position</b></p>  <p><b>Select</b></p>  <p>Choices :</p> <ul style="list-style-type: none"> <li>■ CHANS</li> <li>FULL</li> <li>MANUAL</li> <li>NB_CHAN</li> <li>NB_MANL</li> </ul>	<p><b>10</b> Position cursor at <b>RUN TEST</b> and select it.</p> <p><b>Position</b></p>  <p><b>Select</b></p>  <p>Procedures take approx. 2 min. to load.</p> <ul style="list-style-type: none"> <li>■ Run Test</li> <li>2 Continue</li> <li>3 Edit Seqn</li> <li>4 Edit Freq</li> <li>5 Edit Spec</li> </ul>

Visual Reference Only:

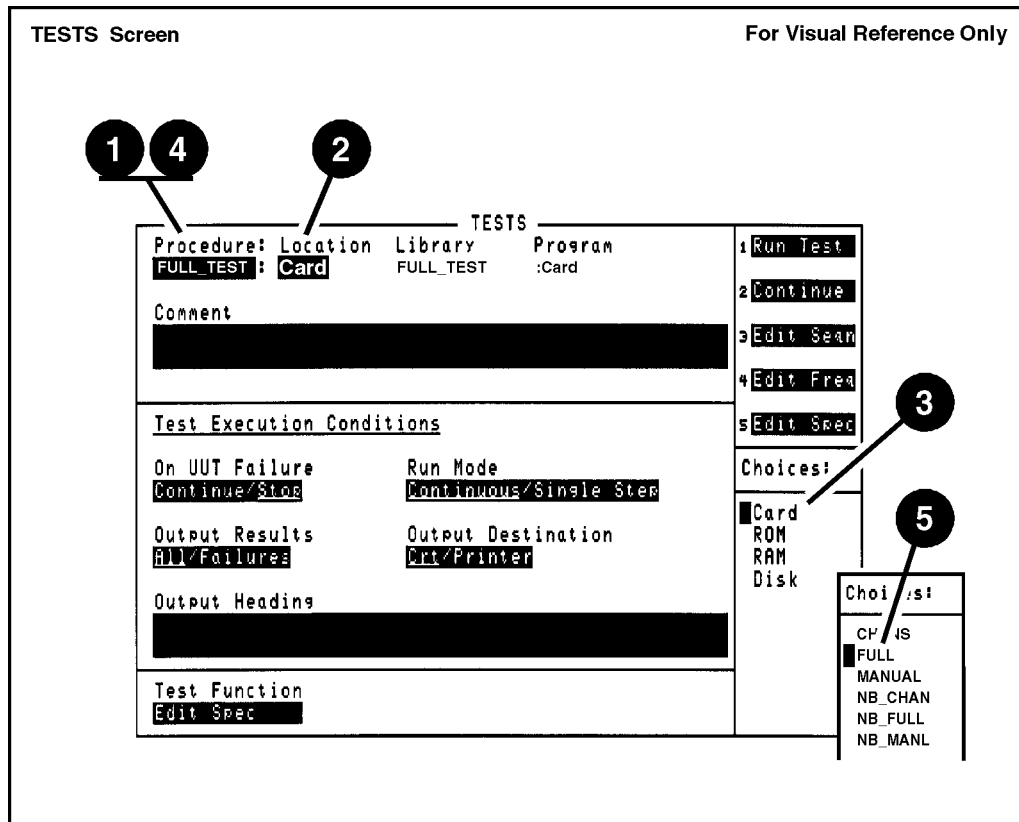



PROCED2

Chapter 2  
Getting Started with FW Below  
Rev. A.14.00

Figure 8

**C. RUN THE AUTOTEST PROCEDURE**

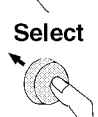
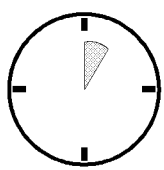
<p><b>1</b> Position cursor at <b>On UUT Failure</b> and select <b>Stop</b>.</p> <div style="display: flex; align-items: center;"> <div style="margin-right: 10px;"> <p><b>Position</b></p>  <p><b>Select</b></p>  </div> <div> <p style="text-align: center;">On UUT Failure</p> <div style="border: 1px solid black; padding: 2px; display: inline-block;">Continue/Stop</div> <p style="text-align: center;">(Underline indicates selected option. Pressing knob changes selection.)</p> </div> </div>	<p>Selecting <b>Stop</b> sets the HP 8920A to stop on failures detected during testing. Selecting this option allows you to make adjustments as failures occur.</p>
<p><b>2</b> Position cursor at <b>Run Test</b> and select it.</p> <div style="display: flex; align-items: center;"> <div style="margin-right: 10px;"> <p><b>Position</b></p>  <p><b>Select</b></p>  </div> <div> <p style="text-align: center;">Run Test</p> <ul style="list-style-type: none"> <li>2 Continue</li> <li>3 Edit Seqn</li> <li>4 Edit Freq</li> <li>5 Edit Spec</li> </ul> </div> </div>	<p><b>3</b> The <b>FULL_TEST</b> software takes approx. 2 min. to load.</p> <div style="text-align: center;">  </div>
<p><b>4</b> Make necessary connections to your radio.</p> <p>While <b>FULL_TEST</b> procedure is loading, use diagram on next page to make necessary connections to your radio.</p>	<p><b>5</b> When choices below appear, turn to next page.</p> <p style="text-align: center;">=&gt;Trunked radio Conventional Radio</p>

RUN1

Next: Turn page to Load the Channel#s and Frequencies



## C1. CONNECT THE CABLES AND POWER-UP THE RADIO

### Hardware Configuration

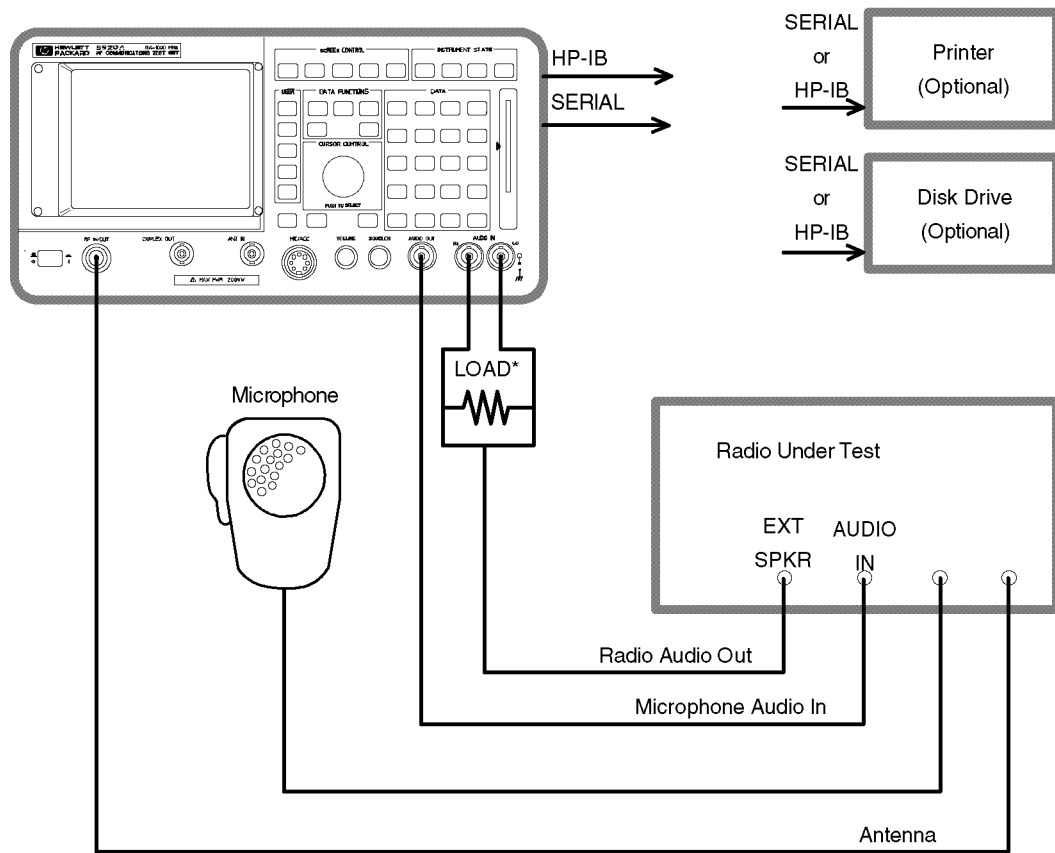











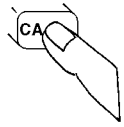
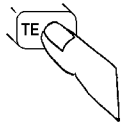





\* Matches audio output impedance of your radio (listed in parameter 28).

FJUN2

Figure 9

**D. LOAD THE CHANNEL#s & FREQUENCIES** Frequencies shown are for example only!

**D. LOAD THE CHANNEL#s & FREQUENCIES** Frequencies shown are for example only!

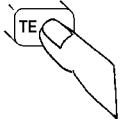
<p><b>1</b> Press <b>CANCEL</b> to pause any IBASIC code that is running.</p> 	<p><b>2</b> Press <b>TESTS</b> to display TESTS screen.</p> 	<p><b>3</b> Position cursor at <b>Test Function</b> and select it.</p> <p>Position </p> <p>Select </p> <p>Test Function</p>
<p><b>4</b> Position cursor at <b>Edit Freq</b> and select it.</p> <p>Position </p> <p>Select </p> <p>Choices :</p> <ul style="list-style-type: none"> <li>■ Edit Seqn</li> <li>■ Edit Freq</li> <li>■ Edit Spec</li> <li>■ Edit Parm</li> <li>■ Edit Cnfg</li> <li>■ Edit Mngr</li> <li>■ IBASIC</li> </ul>	<p><b>5</b> Select, scroll to <b>Chan# 1</b>, then select again.</p> <p>Select </p> <p>Scroll </p> <p>1 857.825000 8</p> <p>(Control Channel)</p>	<p><b>6</b> Position cursor as shown, key-in correct RX Freq, then select it.</p> <p>Position (Use DATA keypad to key-in correct value) </p> <p>Key-in 1 123.456789 812 </p>
<p><b>7</b> Position cursor as shown below.</p> <p>Select </p> <p>Position </p> <p>123.456789 812.825000</p>	<p><b>8</b> Key-in correct TX frequency, then select it.</p> <p>Key-in </p> <p>Select </p> <p>123.456789 123.456789</p> <p>(Use DATA keypad to key-in correct value)</p>	<p><b>9</b> Position cursor at each field below and position underline to <b>No</b>.</p> <p>Position </p> <p>Position </p> <p>Yes/No Yes/No</p> <p>(To position line, press knob)</p>
<p><b>10</b> Position cursor at <b>Chan#</b> field and repeat steps 5-8 for <b>Chan# 2</b>. Set <b>Test?</b> and <b>Prime?</b> to <b>Yes</b>.</p> <p>Position </p> <p>2 857.825000 812.825000 Yes/No Yes/No</p> <p>(Working Channel)</p>		<p><b>11</b> Press <b>TESTS</b> to display the TESTS screen.</p> 

FRQCHN1

Next: Turn page to Set the Audio Level and Impedance

Visual Reference Only

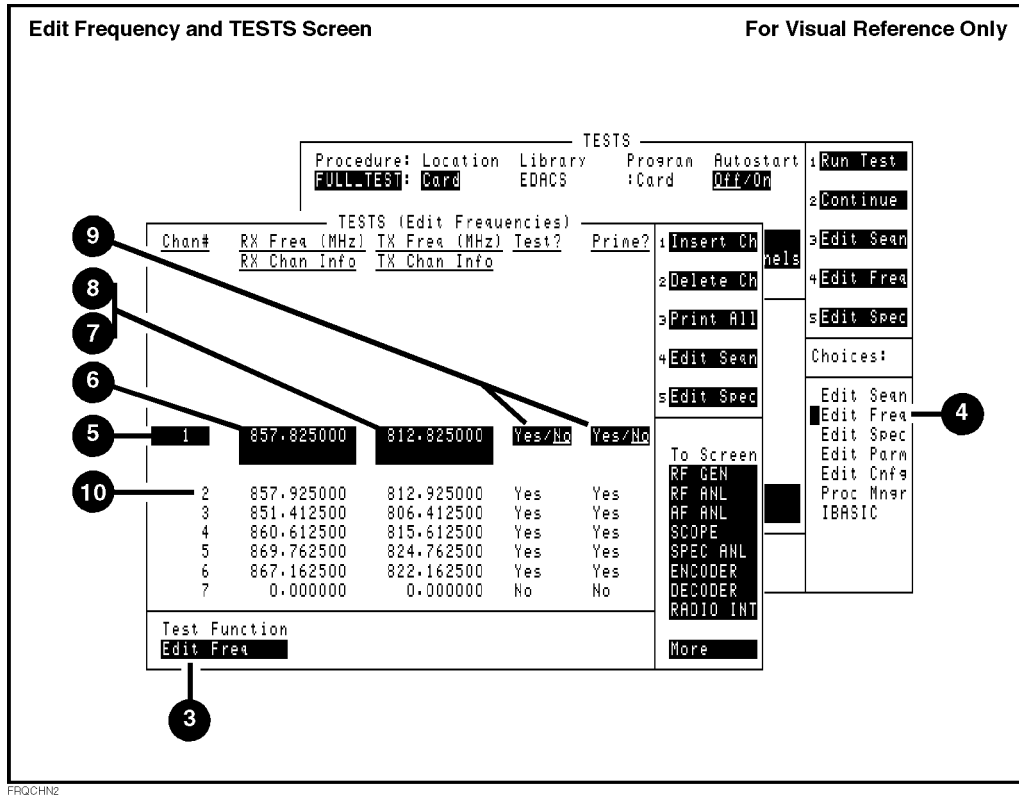
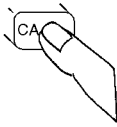
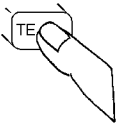















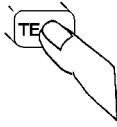



Figure 10

Chapter 2  
 Getting Started with FW Below  
 Rev. A.14.00

**E. SET THE AUDIO LEVEL AND IMPEDANCE Assumes 8 Ohms @ 2 Watts, for example only!**

**E. SET THE AUDIO LEVEL AND IMPEDANCE  
Assumes 8 Ohms @ 2 Watts, for example only!**

<p><b>1</b> Press <b>CANCEL</b> to pause any IBASIC code that is running.</p> 	<p><b>2</b> Press <b>TESTS</b> to display TESTS screen.</p> 	<p><b>3</b> Position cursor at <b>Test Function</b> and select it.</p> <p>Position</p>  <p>Select</p> 
<p><b>4</b> Position cursor at <b>Edit Parm</b> and select it.</p> <p>Position</p>  <p>Select</p>  <p>Choices :</p> <ul style="list-style-type: none"> <li>Edit Seqn</li> <li>Edit Freq</li> <li>Edit Spec</li> <li>Edit Parm</li> <li>Edit Cnfg</li> <li>Edit Mngr</li> <li>IBASIC</li> </ul>	<p><b>5</b> Position cursor at <b>Parm#</b> field and select it.</p> <p>Position</p>  <p>Select</p>  <p>(Entries on your display may be different)</p> <p>1 AA use GN valu 4.000000</p>	<p><b>6</b> Rotate knob to scroll to <b>RX audio load.....</b>, and select it.</p> <p>Rotate</p>  <p>Select</p>  <p>(This parameter number is subject to change)</p> <p>30 RX audio load impe 4.000000 Ohms</p>
<p><b>7</b> Position cursor at <b>Value</b> field, key-in the value, then select it..</p> <p>Key-in</p>  <p>Select</p>  <p>(Use <b>DATA</b> keypad to key-in new value)</p> <p>30 RX audio load imp 8.000000 Ohm</p>	<p><b>8</b> Position cursor at <b>Parm#</b> field and select it.</p> <p>Position</p>  <p>Select</p>  <p>30 RX audio load in 8.000000 Ohm</p>	<p><b>9</b> Rotate knob to scroll to <b>RX audio maxim.....</b>, and select it.</p> <p>Position</p>  <p>Select</p>  <p>31 RX audio maximu 1.000000 Watts</p>
<p><b>10</b> Position cursor at <b>Value</b> field, key-in the value, then select it.</p> <p>Key-in</p>  <p>Select</p>  <p>(Use <b>DATA</b> keypad to key-in new value)</p> <p>30 RX audio maximu 2.000000 Watts</p>	<p><b>11</b> Press <b>TESTS</b> to display TESTS screen.</p> 	<p><b>12</b> Position cursor at <b>Run Test</b> and select it.</p> <p>Position</p>  <p>Select</p>  <ul style="list-style-type: none"> <li>Run Test</li> <li>2 Continue</li> <li>3 Edit Seqn</li> <li>4 Edit Freq</li> <li>5 Edit Spec</li> </ul>

PARM1

Next: Turn page to Set Chan#, Group ID, Logical ID and Site ID

**VISUAL REFERENCE ONLY**

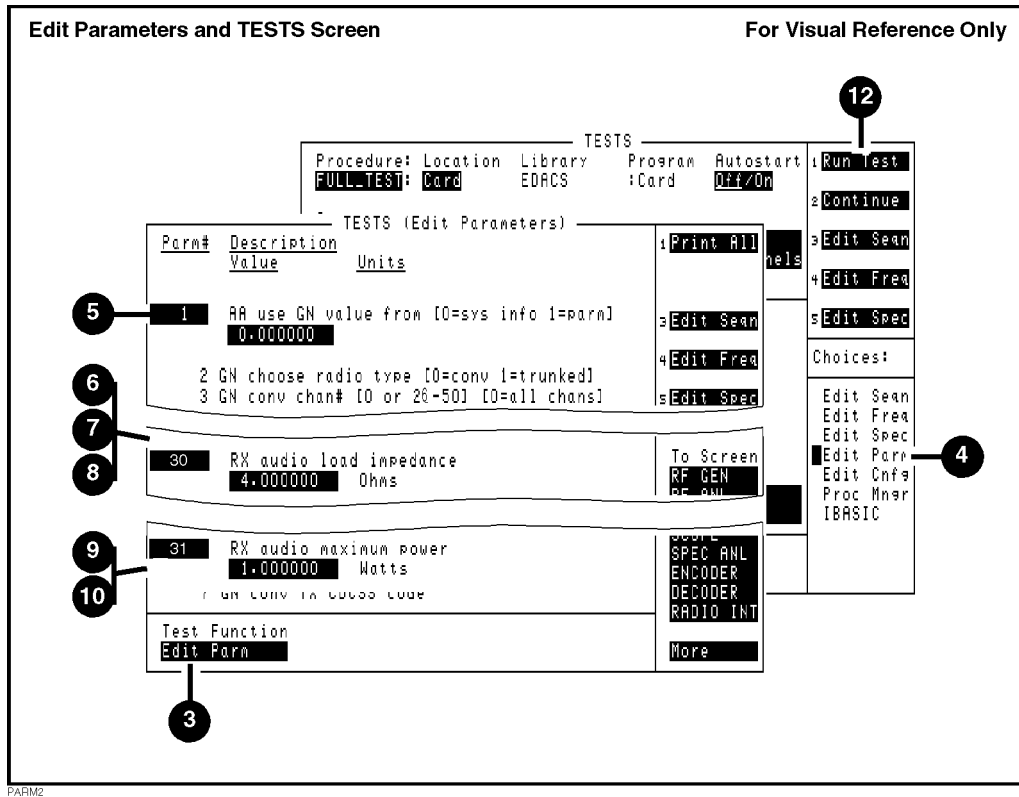













Figure 11

## F. SET CHAN#s, GROUP ID, LOGICAL ID, SITE ID

<p><b>1</b> Position arrow at <b>Trunked radio</b> and select it.</p> <p><b>Position</b>   ==&gt;Trunked radio          Conventional Radio</p> <p><b>Select</b>  </p>	<p><b>2</b> Position arrow at <b>Working Channel</b> and select it.</p> <p><b>Position</b>   ==&gt;Working channel : 5          Control channel : 1          Group ID : 2035          Logical ID : 4095          Site ID : 1          Call Type :Group          Callee ID (Indv Call) :4093</p> <p><b>Select</b>  </p>	<p><b>3</b> Press 5 on <b>DATA</b> keypad, then select it.</p> <p><b>Press</b>  </p> <p><b>Select</b>  </p> <p style="text-align: center;">DATA</p> <table border="1" style="margin-left: auto; margin-right: auto;"> <tr> <td>7</td> <td>8</td> <td>9</td> <td>ENTER</td> </tr> <tr> <td>4</td> <td>5</td> <td>6</td> <td>GHz dBm</td> </tr> <tr> <td>1</td> <td>2</td> <td>3</td> <td>MHz V</td> </tr> </table>	7	8	9	ENTER	4	5	6	GHz dBm	1	2	3	MHz V																
7	8	9	ENTER																											
4	5	6	GHz dBm																											
1	2	3	MHz V																											
<p><b>4</b> Position arrow at <b>Group ID</b> and select it.</p> <p><b>Position</b>   Begin testing : 5          Working channel : 1          Control channel : 1          ==&gt; Group ID : 2035          Logical ID : 4095          Site ID : 1          Call Type :Group          Callee ID (Indv Call) :4093</p> <p><b>Select</b>  </p>	<p><b>5</b> Key-in appropriate <b>Group ID</b>, then select it.</p> <p><b>Key-in</b>  </p> <p><b>Select</b>  </p> <p style="text-align: center;">DATA</p> <table border="1" style="margin-left: auto; margin-right: auto;"> <tr> <td>7</td> <td>8</td> <td>9</td> <td>ENTER</td> </tr> <tr> <td>4</td> <td>5</td> <td>6</td> <td>GHz dBm</td> </tr> <tr> <td>1</td> <td>2</td> <td>3</td> <td>MHz V</td> </tr> </table>	7	8	9	ENTER	4	5	6	GHz dBm	1	2	3	MHz V	<p><b>6</b> If required, repeat steps 4 and 5 for other setting.</p> <p><b>Change if required</b></p> <table border="1" style="margin-left: auto; margin-right: auto;"> <tr> <td>Begin testing</td> <td>: 5</td> </tr> <tr> <td>Working channel</td> <td>: 1</td> </tr> <tr> <td>Control channel</td> <td>: 1</td> </tr> <tr> <td>Group ID</td> <td>: 2035</td> </tr> <tr> <td>Logical ID</td> <td>: 4095</td> </tr> <tr> <td>Site ID</td> <td>: 1</td> </tr> <tr> <td>Call Type</td> <td>:Group</td> </tr> <tr> <td>Callee ID (Indv Call)</td> <td>:4093</td> </tr> </table>	Begin testing	: 5	Working channel	: 1	Control channel	: 1	Group ID	: 2035	Logical ID	: 4095	Site ID	: 1	Call Type	:Group	Callee ID (Indv Call)	:4093
7	8	9	ENTER																											
4	5	6	GHz dBm																											
1	2	3	MHz V																											
Begin testing	: 5																													
Working channel	: 1																													
Control channel	: 1																													
Group ID	: 2035																													
Logical ID	: 4095																													
Site ID	: 1																													
Call Type	:Group																													
Callee ID (Indv Call)	:4093																													
<p><b>7</b> Confirm all settings are correct, then go to step 8.</p> <p style="text-align: center;"><b>Note</b></p> <p>If you need to make changes to frequency settings, go to <b>Task D. LOAD CHAN#s.</b></p>	<p><b>8</b> Position arrow at <b>Begin testing</b> and select it.</p> <p><b>Position</b>   ==&gt;Begin testing          Working channel : 5          Control channel : 1          Group ID : 2035          Logical ID : 4095          Site ID : 1          Call Type :Group          Callee ID (Indv Call) :4093</p> <p><b>Select</b>  </p>	<p style="text-align: center;"><b>Turn page to continue.</b></p>																												

SY5INFO1

Next: Turn page to begin Autotesting the EDACS Radio

## Visual Reference Only

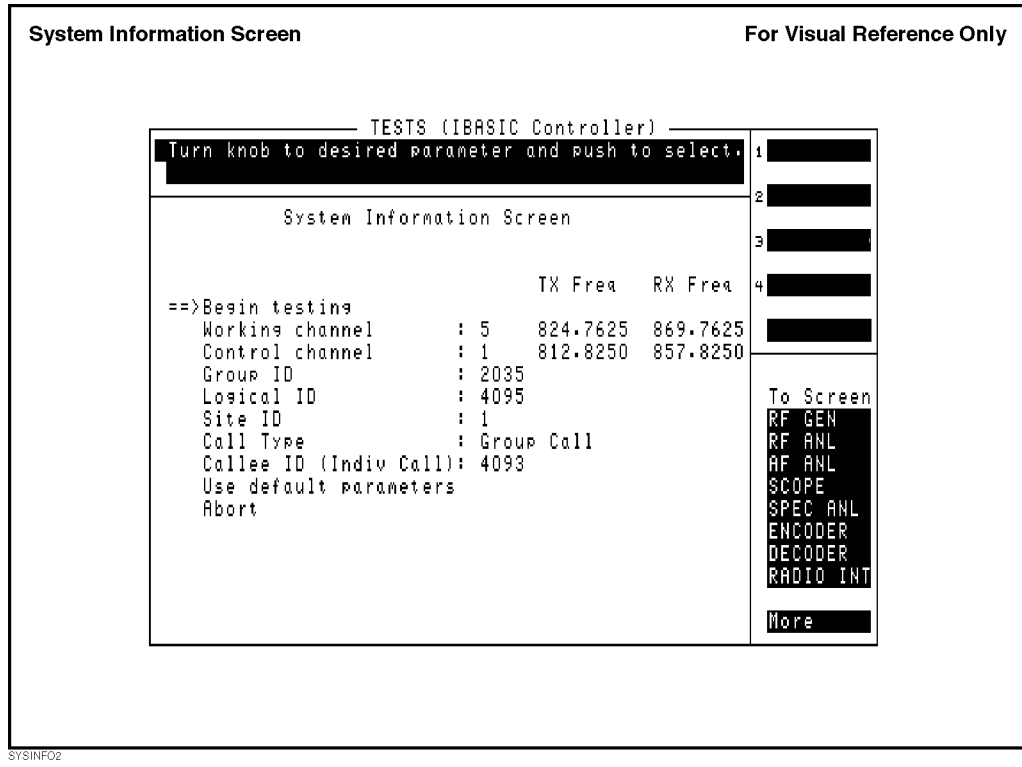

Figure 12

G. AUTOTESTING THE EDACS RADIO

G. AUTOTESTING THE EDACS RADIO

**1** On next three screens, do instructions in highlighted box at top of screen, then position cursor at **Continue** and select it.

**Position** (1A) →

```

TESTS (IBASIC Controller)
Verify transmitter is de-keyed. Press Continue.
-----
Performs quick tests on one channel for radios
with EDACS trunked and/or conventional FM channels
-----
TESTS (IBASIC Controller)
Set radio to the system programmed with Trunked
Chan 2: RX=897.925 MHz: TX=812.925 MHz
-----
Performs quick tests on one channel for radios
with EDACS trunked and/or conventional FM channels
-----
TESTS (IBASIC Controller)
* * #Set radio# * *
Set radio VOLUME to maximum. Press Continue.
-----
Performs quick tests on one channel for radios
with EDACS trunked and/or conventional FM channels
-----
Test conditions           Measured value   P/F
-----
-----Chan=5: RX=869.7625 MHz: TX=824.7625 MHz-----
    
```

**Select** (1B) → (1C) →

**2** On next three screens, adjust volume until indicator resides between large graticules on meter; program will proceed automatically.

**Position** (2A) →

```

TESTS (IBASIC Controller)
* * #Set radio# * *
VOLUME
-----
Volume (Watts)
TESTS (IBASIC Controller)
* * #Set radio# * *
VOLUME
-----
Volume (Watts)
TESTS (IBASIC Controller)
* * #Set radio# * *
VOLUME
-----
Volume (Watts)
    
```

**Select** (2B) → (2C) →

**Note**  
If you are unable to set volume within graticules, adjust it as close as possible, then position cursor at **Take It** and select it.

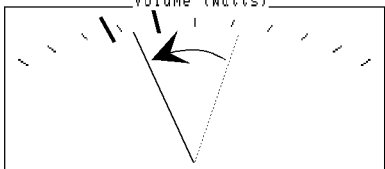

To Screen  
RF GEN  
RF SW

Next: Continue on the next page



## AUTOTESTING THE RADIO

**3** To proceed through remaining test screens, follow instructions displayed in highlighted box at top of screen.

Follow instructions in this box

TESTS (IBASIC Controller)

---

Performs quick tests on one channel for radios with EDACS trunked and/or conventional FM channels

-----

Test conditions	Measured value	P/F
-----		
_____Chan 5: RX=869.7625 MHz: TX=824.7625 MHz_____		
-----		
_____Call type = Group Call_____		
RX audio sen @40% rated dev	0.0 Watts	F
RX audio distn 17 dB down	92.9 %	F
RX audio distortion	96.9 %	F
RX SINAD @ .2 uV	1.5 dB	F
RX hum & noise unsquelched	-5 dB	F
RX audio resp @ .30 kHz	-10.7 dB error	F
RX audio resp @ .80 kHz	-1.7 dB error	F
RX audio resp @ 1.30 kHz	2.2 dB error	F
RX audio resp @ 1.80 kHz	5.3 dB error	F
RX audio resp @ 2.30 kHz	7.2 dB error	F

If F appears in this column, program has Stopped on Failure; go to Task H.

**4** When test results are displayed at bottom of screen, testing has finished and cabling may be disconnected.

Verify test results here

TESTS (IBASIC Controller)

---

RX audio distn 17 dB down	4.6 %
RX audio distortion	5.0 %
RX SINAD @ .2 uV	11.4 dB
RX hum & noise unsquelched	29.6 dB
RX audio resp @ .30 kHz	-2.0 dB error
RX audio resp @ .80 kHz	-.4 dB error
RX audio resp @ 1.30 kHz	-.8 dB error
RX audio resp @ 1.80 kHz	-2.1 dB error
RX audio resp @ 2.30 kHz	-2.9 dB error
RX audio resp @ 2.80 kHz	-4.3 dB error
RX audio resp @ 3.00 kHz	-4.4 dB error
RX trunking opening:	
RX SINAD @ .3 uV	20.3 dB

Points passed= 13: Points failed= 1

Test time= 250 secs.

FULLTST2

---

## H. AUTOTESTING STOPPED ON A FAILURE

*The program has stopped and you see an F in the P/F column. NOW WHAT?*

There are several ways to proceed:

- a. The screen will prompt “Press Continue when ready”. Position the cursor and select “Continue”. Troubleshooting to the component level may be necessary.
- b. Before repairing the radio consider these additional sources of the failure:
  - i. Are all cables connected properly?
  - ii. Have you followed all alignment, cabling, and setup procedures?
  - iii. Verify the specifications and parameters in **chapter 7, "Test, Parameter, and Pass/Fail Limit (Specification) Descriptions"**, in the *HP 11807A,E Opt 011 Software User's Guide*.
  - iv. Confirm all frequencies, ID#,s, Channel#,s, and parameters in Tasks D, E, & F.
- c. Is the HP 8920A working properly? The HP 8920A has a self-test, see the *HP 8920A User's Guide*.

## I. TROUBLE CHECK

Task	Symptom	Cause	Corrective Action	Ref
A	Power doesn't turn ON	Line cord not attached	Attach line cord	1
		HP 8920A warm-up delay	Wait 20 seconds	A
		AC/DC switch in wrong setting	Set AC/DC to AC	1
A-F	Wrong screen display	HP 8920A warm-up delay	Wait 20 secs; press PRESET	A
		Pressed knob while rotating	Repeat start-up sequence	A
		Rotated knob while pressing	Repeat start-up sequence	A
B-C	No Procedures, Error 80	Improperly inserted CARD	Orient & insert firmly	A
		Improper CARD	Verify HP 11807A Opt 011	A
G	'Audio level < 5% of max power	audio set too low	increase audio volume	6-11 <sup>2</sup>
		RX Handshake unsuccessful	Press K1: RX Hndshk	
		wrong frequencies	correct frequencies	task D
		improper ID #s	correct ID#s	task F
		improper cabling	correct cabling	Figure 3
G	Audio won't set	incorrect Parameters	Edit Parameters	6-11 <sup>2</sup>
A	Wrong screen on restart	Shows last screen until HP 8920A is finished thinking	Wait 20 seconds	1
		IBASIC is still running	Press CANCEL to pause IBASIC prior to TESTS or PRESET keys	1
G	Tests stopped, won't continue	Stopped on UUT failure	select Continue	H
G	Measurement failed spec	Incorrect spec value	Edit spec values	K & <sup>2</sup>
		Incorrect parameter value	Edit parameter values	L & <sup>2</sup>
		Faulty cabling	Repeat cabling instructions	Figure3
		Faulty radio	Repair/adjust radio	
G	Error message: 'No handshake with the UUT. Try again?'	Control Channel not responding	if you've gotten this far then it's probably radio insensitivity	2
		Control Chan drops out > 5secs	restart Procedure: select CANCEL, TESTS, Run Test	A
		slight frequency inaccuracy	re-try several times	

1. HP 8920A,B User's Guide, Part Number 08920-90203
2. HP 11807A,E Opt 011 Software User's Guide, Part Number 11807-90126. See also [chapter 9](#) in the HP 11807A,E Option 011 Software User's Guide.

---

## J. IF YOU HAVE A PROBLEM

### If you cannot find what you are looking for on the screen

- Verify that the correct HP 8920A screen is displayed in each task.
- Corresponding correct reference screens are illustrated on the pages opposite tasks A, B, D, E, F, and G etc.
- The reference screens also indicate the position of required fields.
- *If you do not see the illustrated screen on your HP 8920A display then, return to step #4, “PRESET” as shown in task A, and repeat all steps.*
- Occasionally, displaying a final screen requires a 7 to 10 second wait for the screen to stabilize following a “select” function.
- Verify that the HP 11807A Option 011 memory card is inserted firmly and is in the proper orientation: task A.
- See also [chapter 9](#) the *HP 11807A Option 011 Software User’s Guide*

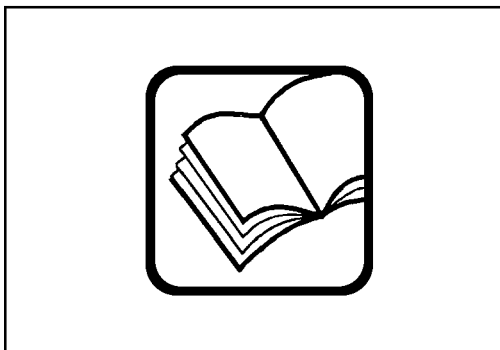

TROUBLE1



### IF YOU NEED ADDITIONAL HELP...

Consult the HP 11807A Option 011 Software User’s Guide or call the HP 8920A Hotline 1-800-922-8920 and give your software model number.

---

## Product Description

## HP 11807A,E Software

The HP 11807A,E Software performs fast, accurate, automated tests that determine the RF and audio performance of conventional and trunked mobile radios using the Ericsson GE EDACS standard. The measurement methods and specifications used for these tests are based on methods and values derived from the following industry standards:

- EIA/TIA-204-D (RX)
- EIA-152-C (TX)
- EIA RS-220 (CTCSS)
- TIA/EIA-603 (RX, TX, Subaudible signaling)

### Materials Included in This Package

This materials. Verify that all the materials are present and inspect them for damage. If a part is missing or appears to be damaged, contact your nearest Hewlett-Packard sales or service office.

- HP 11807A Option 011 Test Software (part number 11807-10023) or HP 11807E Option 011 Test Software (part number 11807-10030).
- SRAM memory card (uninitialized), for saving your own test procedures and results.
  - For HP 11807A, 32 Kbyte SRAM (part number HP 85700A).
  - For HP 11807E, 64 Kbyte SRAM (part number HP 83230A).
- HP 11807A,E Option 011 Software Reference Guide (part number 11807-90126)
- HP software product license agreement

## Additional Equipment Required

- HP 8920A RF Communications Test Set or 8920D Dual Mode Cellular Test System, equipped as follows -
  - 8920A serial prefix greater than or equal to 3344 (SER 3344AXXXXX, displayed on the rear panel).
  - HP 8920A Option 004: Tone/Digital Signaling
  - HP 8920A Option 005: 512k RAM expansion.
  - HP 8920A firmware revision *A.10.07* or above. The revision is displayed in the upper-right corner of the I/O CONFIGURE screen. To access this screen, select the **More** field (located at the bottom-right corner of the TESTS screen), then select **IO CONFIG**.

## Recommended Equipment

- HP 8920A Option 001: High-Stability Timebase
- HP 8920A Option 003: HP-IB/Serial Communications/Current Measurement - only *required* for current measurements.
- HP 8920A Option 010: 400 Hz High-Pass Filter (HPF) (for tests 04-09)
- Programmable power supply - only *required* when making transmitter power measurements at high and low power supply settings. This must be an IEEE 488.2 SCPI-compatible supply, such as the HP 6651A through HP 6655A series.

## Ordering Upgrades

If your HP 8920A does not contain all of the required options, or has an earlier firmware revision or serial number, you must update your instrument accordingly. Order the necessary upgrade kit(s) from your local Hewlett-Packard sales office. Regional sales offices are listed at front of this manual.

### Required Upgrades

- For instruments with serial prefix less than 3248A, order the Tone/Digital Signaling retrofit kit (HP 8920A Option 004): part number 08920-61052
- HP 8920A Option 004: Tone/Digital Signaling retrofit kit: part number 08920-61052
- HP 8920A Option 005: 512 k RAM expansion retrofit kit: part number 08920-61053
- For firmware revisions prior to *A.10.07*, order Firmware Upgrade kit: part number 08920-61058

### Recommended Upgrades

- HP 8920A Option 001: High Stability Timebase retrofit kit: part number 08920-61835
- HP 8920A Option 003: HP-IB/Serial Communications/Current Measurement retrofit kit: part number 08920-61818
- HP 8920A Option 010: 400 Hz High Pass Filter (HPF) retrofit kit: part number 08920-61054. (A maximum of two optional filters can be installed in your HP 8920A. If you already have two optional filters installed, one of them must be removed before installing this kit.)

### Available Tests:

The following tests can be performed with this software.

1. Transmitter and Receiver stand-by current drain
2. Transmitter frequency error
3. Transmitter output power
4. Transmitter modulation limiting
5. Transmitter audio frequency response
6. Transmitter audio distortion
7. Transmitter microphone sensitivity
8. Transmitter FM hum and noise
9. Transmitter residual AM hum and noise
10. Transmitter signaling deviation & frequency/code
11. Receiver hum and noise
12. Receiver audio distortion
13. Receiver frequency response
14. Receiver usable sensitivity
15. Receiver (conventional) audio squelch sensitivity
16. Receiver (conventional) squelch blocking
17. Receiver squelch opening with signaling
18. Receiver audio sensitivity
19. Receiver (conventional) signal displacement bw



Combinations of these tests are pre-configured under the following test names:

20. Receiver quick test: This test performs tests 11 through 18 listed above.
21. Transmitter quick test: This test performs tests 2 through 10 listed above.
22. RT manual test: This test allows you to do some basic transmitter and receiver tests. This test differs in operation from the other tests by continually displaying updated measurement results as long as a measurement is selected: the other tests make a single measurement for each data point, and then display the result.
23. TX transient frequency behavior

For test, parameter, and pass/fail limit descriptions, see [chapter 7](#).

## Software Features

The following features simplify testing:

- While adjustments are being made, a large meter display and auditory feedback are provided.
- Results of tests and pass/fail indications are displayed on the Test Set CRT, and can be printed, or collected in a disk drive, memory card, PC, or HP Palmtop computer.
- The software allows the operator to change testing order, pass/fail limits, parameters and external device configurations.

---

## Finding the Information You Need

This manual describes the setup and use of the HP 11807A,E Software with the HP 8920A,D Test Set. The book is arranged in self-contained chapters to provide the following information:

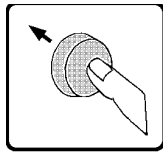

### GETTING STARTED

- Fast-paced, hands on tutorial.
- Basic test set/software operation.
- First-time or occasional users.

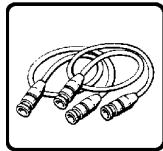

### MAKING CONNECTIONS-CHAPTER 4

- Instructions for cabling test set.

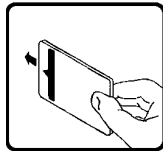

### USING THE SOFTWARE-CHAPTERS 5 & 6

- How to load
- How to run
- How to customize
- Conceptual overview



### TEST, PARAMETER, AND SPECIFICATION DESCRIPTIONS-CHAPTER 7

Definitions, special conditions, and restrictions for:

- Tests
- Specifications-Pass/fail limits
- Parameters-Test conditions



### REFERENCE-CHAPTER 8

- Detailed descriptions of all the features and functions of the HP 11807A software. (alphabetically listed)
- For the advanced level user.



### PROBLEM SOLVING-CHAPTER 9

- Symptoms and possible corrections to frequent problems. (alphabetically listed)

MANUAL1

---

## Additional Services Available

Consult the *HP 8920A User's Guide* or call the HP 8920A,D Hotline 1-800-922-8920 (in the USA and Canada only) and give your software model number.

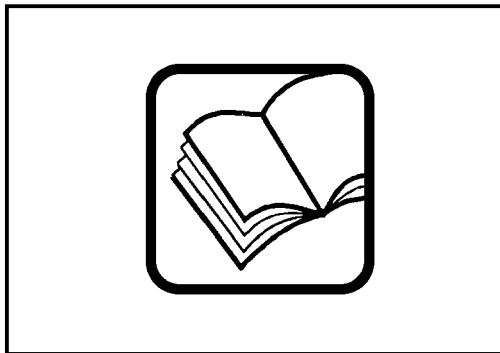

TROUBLE1-1

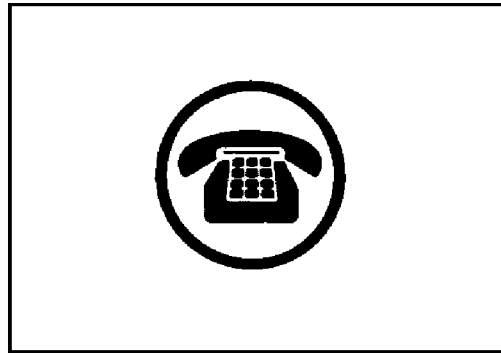



---

## Making Connections

---

## What You Should Know Before Making Connections

Although this manual provides instructions for connecting the test set, it is helpful to understand the basic operation of the HP 8920A,D. Refer to the *HP 8920A User's Guide* for information concerning:

- Safety considerations.
- Providing power to the HP 8920A,D.
- Maximum signal levels for all connectors.

---

### **TRANSMITTER CURRENT LIMITING**

If a programmable power supply is listed on the External Devices (or Edit Configuration) screen, maximum power supply current is limited to  $1.1 \times$  pass/fail limit *TX current drain*. For example, if this pass/fail limit's value is set to 10 Amps, power supply current will be limited to 11 Amps.

Before testing, make sure this value is set high enough to allow proper operation of the radio under test.

---

**Hardware Configuration**

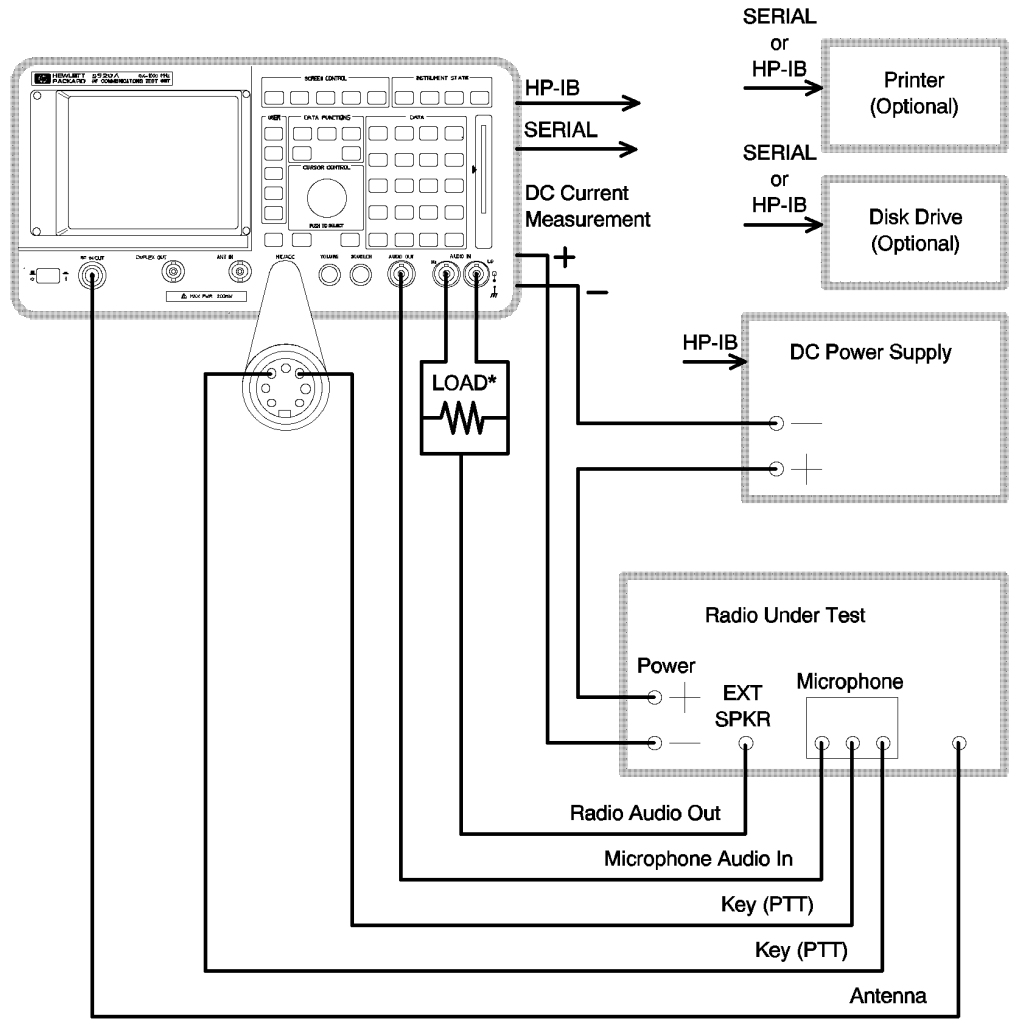

\* Matches audio output impedance of your radio (listed in parameter 28).

TESTC1

## Required and Optional Connections

The Hardware Configuration drawing on the previous page indicates the connections required to perform all tests under *automatic control* (although the software may still prompt you to make some manual radio adjustments). Some connections can be deleted, but may limit the tests that can be performed or change the way the test is performed when run.

The following tables indicate which connections are required and which connections are optional for each test.

**Table 1 Required Connections for Tests 1-12**

HP 8920A to Radio Connections X = Required O = Optional	Test Number											
	1	2	3	4	5	6	7	8	9	10	11	12
RF IN/OUT ⇒ Antenna	<sup>1</sup> X	X	X	X	X	X	X	X	X	X	X	X
DC CURRENT MEAS ⇒ Pwr Supply	<sup>2</sup> X	O	O	O	O	O	O	O	O	O	O	O
MIC/ACC ⇒ Microphone Key	O	O	O	O	O	O	O	O	O	O	O	O
AUDIO OUT ⇒ Microphone In	O	O	O	X	X	X	X	X	O	X	X	X
AUDIO IN ⇒ Ext. Speaker	O	O	O	O	O	O	O	O	O	O	X	X
Audio Load Across AUDIO IN	O	O	O	O	O	O	O	O	O	O	X	X
HP-IB ⇒ Programmable Pwr Supply <sup>3</sup>	X	X	X	X	X	X	X	X	X	X	X	X

1. Not “required” for this measurement but provides an external load for the transmitter when keyed.
2. Not required if a programmable power supply with current measuring is used.
3. Required any time an optional programmable power supply is used.



**Table 2** Required Connections for Tests 13 - 23

HP 8920A to Radio Connections X = Required 0 = Optional	Test Number										
	13	14	15	16	17	18	19	20	21	22	23
RF IN/OUT ⇒ Antenna	X	X	X	X	X	X	X	X	X	X	X
DC CURRENT MEAS ⇒ Pwr Supply	O	O	O	O	O	O	O	O	O	O	O
MIC/ACC ⇒ Microphone Key	O	O	O	O	O	O	O	O	O	O	O
AUDIO OUT ⇒ Microphone In	O	O	O	O	O	O	O	O	X	X	X
AUDIO IN ⇒ Ext. Speaker	X	X	X	X	X	X	X	X	O	X	O
Audio Load Across AUDIO IN	X	X	X	X	X	X	X	X	O	X	O
HP-IB ⇒ Programmable Pwr Supply	X	X	X	X	X	X	X	X	X	X	X

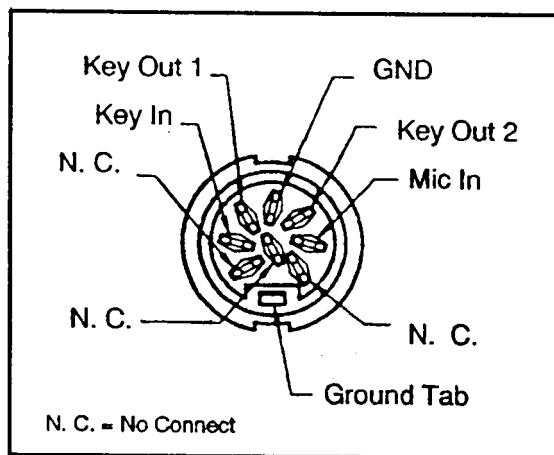

**Figure 13** Exploded View of MIC/ACC Connections



---

**5**

---

**Using the Software/HP 8920B, or HP  
8920A FW Above Rev. A.14.00**

## Firmware Enhancements

**NOTE:** The firmware revision A.14.00 in the HP 8920A,D had several enhancements, which are standard in the HP 8920B. This chapter applies to users with:

- **HP 8920A test sets with firmware revision above A.14.00**
- **All HP 8920B test sets.**

The test set's firmware revision is displayed on the top right corner of the configuration screen.

- Press SHIFT CONFIG to display the configuration screen and read the firmware revision.

If you have an HP 8920A test set with firmware revision below A.14.00, refer to [chapter 2, "Getting Started with FW Below Rev A.14.00"](#). Contact Hewlett-Packard at 1-800-922-8920 for details on upgrading your firmware if desired.

---

The software can be run on the factory default settings or customized to your individual needs and specific requirements. This chapter provides detailed information on how to load, run, and customize the software.

The test set has two methods of accessing on-line help. In each of the screens in the test environment, k4 (**He1p**) accesses specific information about how to set up/use the current screen. SHIFT HELP accesses the master help file, with an alphabetical listing of help topics.

## What You Should Know Before Using the Software

To properly operate this software, you must understand the manual operation of your radio, and the various configuration information programmed into it. Operating information should be provided in the radio's manual. Programmed information must be provided by the programmer, or by reading the information over a data bus.

To be able to test your radio, you must know:

- Which channels are conventional and which are trunked.
- The transmit and receive frequencies for each channel.
- Conventional radio settings:
  - Squelch type.
  - Squelch tone frequency for CTCSS radios.
  - Squelch code for CDCSS radios.
- Trunked radio settings:
  - Control channel number.
  - Working channel numbers.
  - Site ID.
  - Logical ID (*may instead be read by software in Test\_22, Read UUT*)
  - Group ID (*may instead be read by software in Test\_22, Read UUT*)
  - Call Type
  - Caller ID for individual calls (*may instead be read by software in Test\_22, Read UUT*)

---

## Testing Overview

Pressing TESTS will display what is called the TESTS (Main Menu) screen. To begin testing, you must first load the software and make connections. From this screen you have the option to:

### Begin running tests:

- The factory default settings are acceptable for your application or
- The software has already been customized and saved to a memory card

### Customize the software:

- Decide which tests you desire to run (Order of Tests)
  - you may want to run all, some, or just one of the tests.
- Specify which channels to test (Channel Information)
  - the FCC RX and TX frequencies will vary from radio to radio, as well as channel to channel.
  - you may want to test one, some, or all of the channels on your radio.
- Change the pass/fail limits for specific measurements (Pass/Fail Limits)
  - you may want the pass/fail limits to have tighter or looser specifications than the default settings.
- Change the test environment and conditions (Test Parameters)
  - decide output format.
  - enter specific information about radio equipment and/or environment.
- Save any or all of the above customized changes to a memory card (Save/Delete Procedure)

### Set up Test Set:

- Print test results or certain screens.
- Decide when and where test results are displayed (**Execution Conditions/Printer Setup**)

## To Run Tests

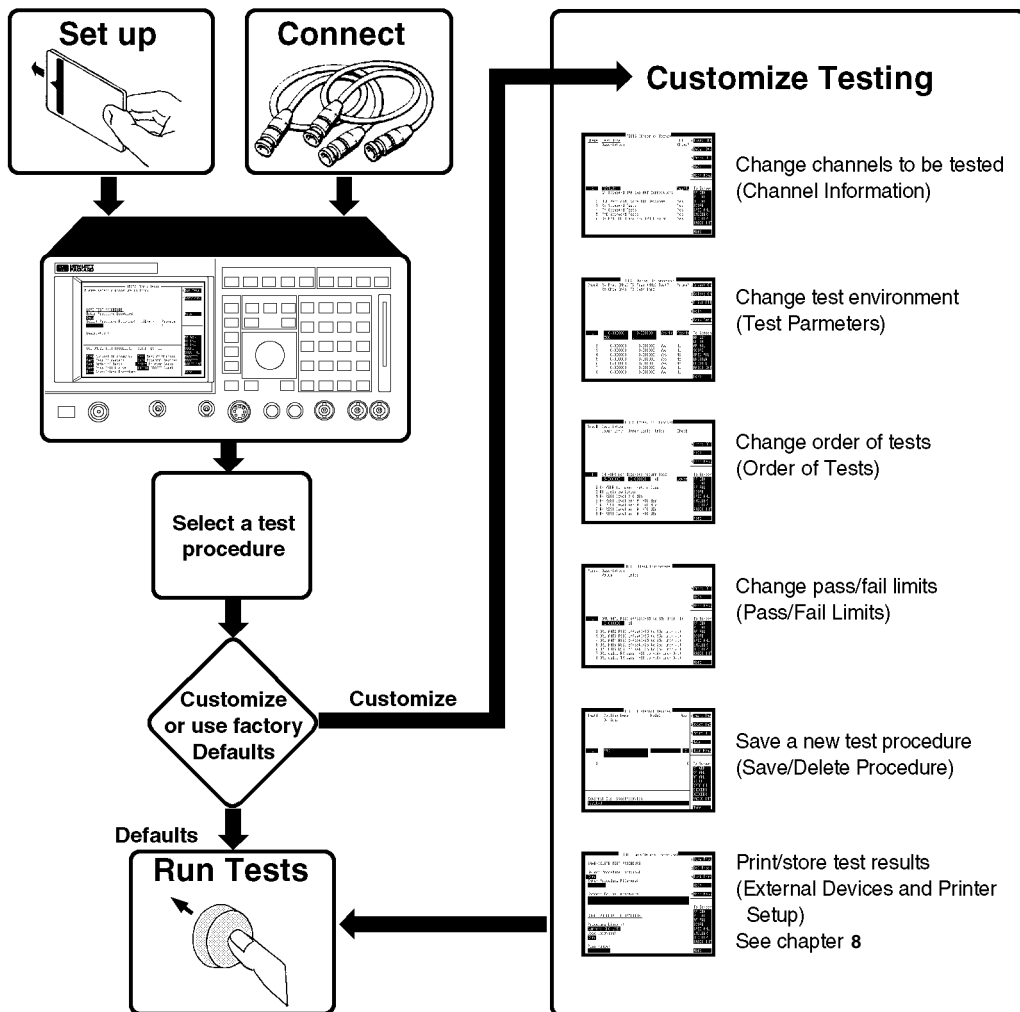

OVERVIEW1



## Setting Up the Test Set and Making Connections

Before you begin testing, you must set up the test set and make the appropriate hardware connections. See [chapter 4, "Making Connections"](#).

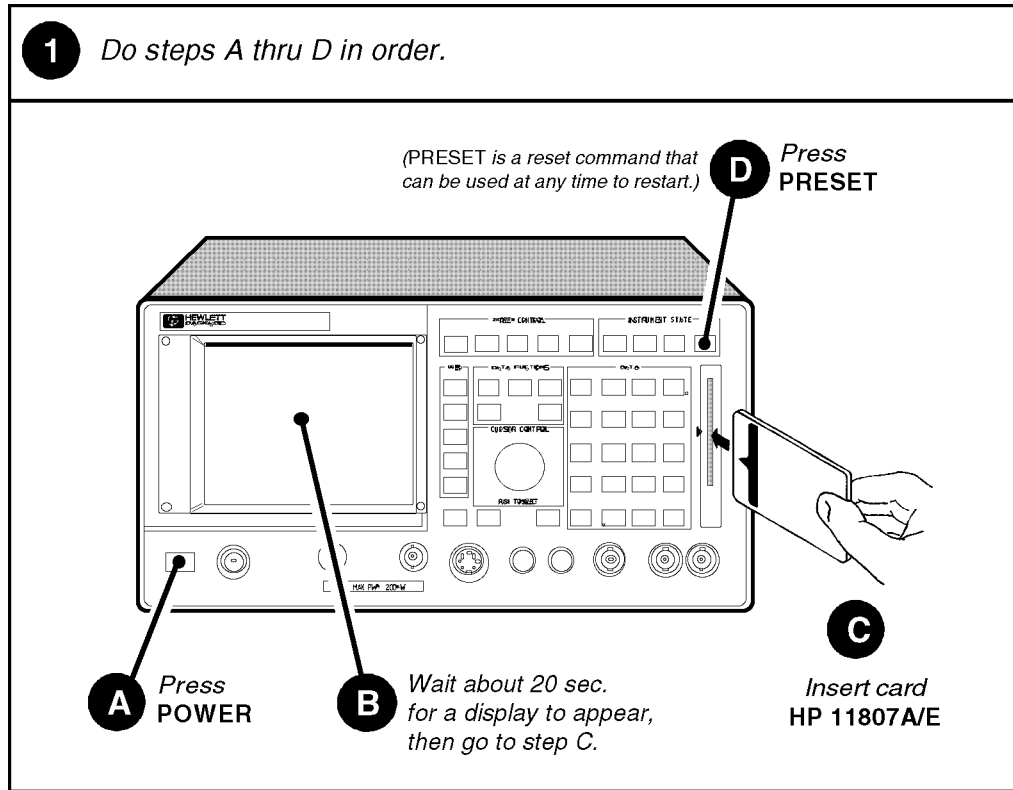

## Selecting a Test Procedure











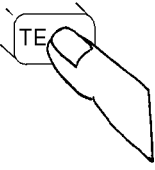

To load the software, you must first select the location to load from (in this case, it will be **Card**) and a procedure filename. Your card comes pre-programmed with at least one procedure. The actual software program does not get loaded into the test set's memory until **k1 (Run Test)** is selected. It will take approximately 15 seconds to load the software in an HP 8920B, and approximately two minutes in an HP 8920A,D.

The software memory card can be removed after the program is loaded into the test set's memory. The program will remain in memory after a power-down/power-up cycle, unless it is manually deleted or a new program is loaded.

When tests begin to run, they are executed in the order in which they were entered into the Test Procedure.

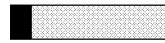
Pressing **CANCEL** will pause the current test (press **k2** to continue the test.)

## Selecting A Test Procedure

<p><b>1</b> Press <b>TESTS</b> to display the <b>TESTS</b> screen.</p>	<p><b>2</b> Position cursor and select <b>Select Procedure Location:</b>.</p>
<p>If you are in <b>IBASIC</b>, press <b>SHIFT, CANCEL</b> before pressing <b>TESTS</b>.</p> 	<p><b>Position</b></p>  <p><b>Select</b></p>  <p>Select Procedure Location:</p> 
<p><b>3</b> Position cursor and select <b>Card</b>.</p>	<p><b>4</b> Position cursor and select <b>Select Procedure Filename:</b>.</p>
<p><b>Position</b></p>  <p><b>Select</b></p>  <p>Choices :</p> <ul style="list-style-type: none"> <li><input checked="" type="checkbox"/> Card</li> <li>ROM</li> <li>RAM</li> <li>Disk</li> </ul>	<p><b>Position</b></p>  <p><b>Select</b></p>  <p>Select Procedure Filename:</p> 
<p><b>5</b> Position cursor and select desired <b>Procedure</b>.</p>	<p><b>6</b> Position cursor and select <b>Run Test</b>.</p>
<p><b>Position</b></p>  <p><b>Select</b></p>  <p>Choices :</p> <ul style="list-style-type: none"> <li><input checked="" type="checkbox"/> XXXXXX</li> <li>XXXXXX</li> <li>XXXXXX</li> <li>XXXXXX</li> </ul>	<p><b>Position</b></p>  <p><b>Select</b></p>  <p>8920A,D ≈ 2 min.          8920B ≈ 15 sec.</p> <p>Run Test</p> <ul style="list-style-type: none"> <li>2 Continue</li> <li>4 Help</li> </ul>

PROCE01

## Customizing Testing

Because of the diversity of individual testing needs, the software has been designed so that changes may be easily made from the test set's front panel. You may store these changes on a memory card so that you may skip these steps in the future. See ["Saving a Test Procedure" on page 102](#).

Because your needs change, the software allows changes to its default settings whenever you need to make them. For example, tests may be inserted or deleted, and later after running the tests you can change the pass/fail limits or decide to test different channels.

Most testing customization is accomplished through the customization screens. These customization screens are accessed from the main TESTS (Main Menu) screen as shown in the following figure. Customizing procedures is explained later in this chapter.

---

**NOTE:** External Devices, Printer Setup, and IBASIC will not be explained in this customizing section.

- External Devices and Printer Setup are used when setting up printers and external disk drives which is explained in ["Disks" on page 241](#) and ["Printing" on page 257](#) in [chapter 8](#).
- IBASIC is used when writing your own programs and is not explained in this manual. If you need to write your own IBASIC programs you may acquire the following manuals:
  - HP 8920A,D
    - *HP Instrument Basic User's Handbook* HP part number E2083-90601.
    - *HP 8920A Programming Manual* HP part number 08920-90220.
  - HP 8920B
    - *HP Instrument Basic User's Handbook Version 2.0* HP part number E2083-90005.
    - *HP 8920B Programming Manual* HP part number 08920-90222.

## How to Customize Testing

**TESTS (Main Menu) Screen**

TESTS (Main Menu)  
 Please select a procedure to load.

1 Run Test  
 2 Continue  
 4 Help

LOAD TEST PROCEDURE:  
 Select Procedure Location:  
 Card  
 Select Procedure Filename: Library: Program:  
 Description:

CUSTOMIZE TEST PROCEDURE:    SET UP TEST SET:

Freq Channel Information	Exec Execution Cond
Param Test Parameters	Cnfg External Devices
Seam Order of Tests	Print Printer Setup
Spec Pass/Fail Limits	IBASIC IBASIC Cntrl
Proc Save/Delete Procedure	

To Screen  
 RF GEN  
 RF ANL  
 AF ANL  
 SCOPE  
 SPEC ANL  
 ENCODER  
 DECODER  
 RADIO INT  
 More

Selecting a Test Function  
 opens a Customization Screen.

CUSTOM1a

## Changing the Order of Tests











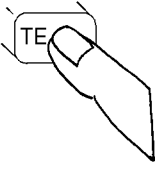









You may define the order of tests to include all, some, or just one of the tests available. When the first test is finished, the next will run. The test sequence will remain in the test set's battery backed-up memory until another test sequence is loaded or set up. For information on saving a customized test sequence, see ["Saving a Test Procedure" on page 102](#).

Defining the order of tests is accomplished by inserting or deleting tests from the list of tests that come with the software package. See [chapter 7, "Test, Parameter, and Pass/Fail Limit \(Specification\) Descriptions," on page 147](#), for descriptions of tests included in this package.

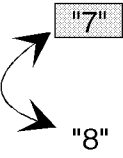
The **All Chans?** field allows the user to decide to run the test on all channels entered in the **Channel Information** table, or just the channels which are selected as **Prime** in the **Channel Information** screen. This feature allows the user the flexibility to use channels that are selected as **Prime** in all the tests in the sequence, and those indicated as non-prime in a subset of tests (those tests with a **Yes** response in **All Chans**). For more information, see ["Specifying Channel Information" on page 90](#).

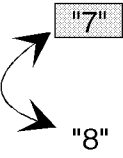

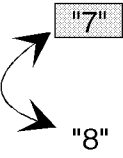





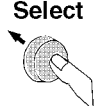
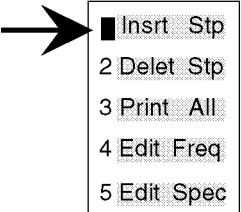

The following describes how to create a new test sequence and enter a response to the **All Chans?** field.

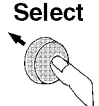
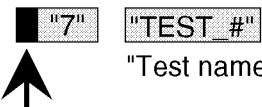
## How to Change the Order of Tests

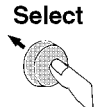
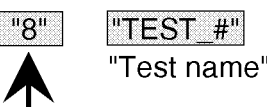
<p><b>1</b> Press <b>TESTS</b> to display the <b>TESTS (Main Menu)</b> screen.</p> <p><i>If you are in IBASIC, press <b>SHIFT, CANCEL</b> before pressing <b>TESTS</b>.</i></p> 	<p><b>2</b> Position cursor and select <b>Seqn Order of Tests</b>.</p> <table border="1"> <tr> <td><b>Position</b></td> <td></td> </tr> <tr> <td></td> <td>Freq Channel Information</td> </tr> <tr> <td></td> <td>Parm Test Parameters</td> </tr> <tr> <td><b>Select</b></td> <td>Seqn Order of Tests</td> </tr> <tr> <td></td> <td>Spec Pass Fail Limits</td> </tr> <tr> <td></td> <td>Proc Save/Delete Procedure</td> </tr> </table>	<b>Position</b>			Freq Channel Information		Parm Test Parameters	<b>Select</b>	Seqn Order of Tests		Spec Pass Fail Limits		Proc Save/Delete Procedure	
<b>Position</b>														
	Freq Channel Information													
	Parm Test Parameters													
<b>Select</b>	Seqn Order of Tests													
	Spec Pass Fail Limits													
	Proc Save/Delete Procedure													
<p>The Order of Tests screen is now present on your CRT.</p>	<p><b>3</b> Position cursor and select <b>Step #</b> field.</p> <table border="1"> <tr> <td><b>Position</b></td> <td></td> </tr> <tr> <td></td> <td>Example</td> </tr> <tr> <td><b>Select</b></td> <td> "1" "TEST 5" "Test name"</td> </tr> </table>	<b>Position</b>			Example	<b>Select</b>	 "1" "TEST 5" "Test name"							
<b>Position</b>														
	Example													
<b>Select</b>	 "1" "TEST 5" "Test name"													
<p><b>4</b> Rotate knob until <b>Step #</b> which precedes the insertion point of the new test you are adding is highlighted, then select it.</p> <table border="1"> <tr> <td><b>Rotate</b></td> <td></td> </tr> <tr> <td></td> <td rowspan="2"> <p>For example, select step 7 if you want to insert the new test as step 8.</p>  </td> </tr> <tr> <td><b>Select</b></td> </tr> <tr> <td></td> <td> <table border="1"> <tr> <td>"7"</td> <td>"TEST #"</td> </tr> <tr> <td></td> <td>"Test name"</td> </tr> <tr> <td>"8"</td> <td>"New test"</td> </tr> </table> </td> </tr> </table>	<b>Rotate</b>			<p>For example, select step 7 if you want to insert the new test as step 8.</p> 	<b>Select</b>		<table border="1"> <tr> <td>"7"</td> <td>"TEST #"</td> </tr> <tr> <td></td> <td>"Test name"</td> </tr> <tr> <td>"8"</td> <td>"New test"</td> </tr> </table>	"7"	"TEST #"		"Test name"	"8"	"New test"	
<b>Rotate</b>														
	<p>For example, select step 7 if you want to insert the new test as step 8.</p> 													
<b>Select</b>														
	<table border="1"> <tr> <td>"7"</td> <td>"TEST #"</td> </tr> <tr> <td></td> <td>"Test name"</td> </tr> <tr> <td>"8"</td> <td>"New test"</td> </tr> </table>	"7"	"TEST #"		"Test name"	"8"	"New test"							
"7"	"TEST #"													
	"Test name"													
"8"	"New test"													

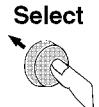
SEQ1

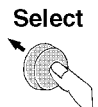
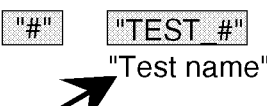
Continue on next page

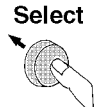
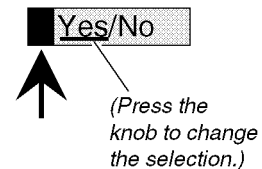
<p><b>5</b> <i>Position cursor and select <b>Insrt Stp.</b></i></p>	<p><b>6</b> <i>Position cursor back at <b>Step #</b> field and select it.</i></p>
<p><b>Position</b></p>  <p><b>Select</b></p>  	<p><b>Position</b></p>  <p><b>Select</b></p>  
<p><b>7</b> <i>Highlight and select <b>Step #</b> field of newly inserted test.</i></p>	<p><b>8</b> <i>Position cursor and select <b>Test Name</b> field.</i></p>
<p><b>Highlight</b></p>  <p><b>Select</b></p>  	<p><b>Position</b></p>  <p><b>Select</b></p>  
<p><b>9</b> <i>Rotate knob and select desired <b>Test Name</b> when it appears.</i></p>	<p><b>10</b> <i>Position cursor at <b>All Chans?</b> field and select <b>Yes</b> or <b>No</b>.</i></p>
<p><b>Rotate</b></p>  <p><b>Select</b></p>  	<p><b>Position</b></p>  <p><b>Select</b></p>  

SEQ2

**Continue on next page**



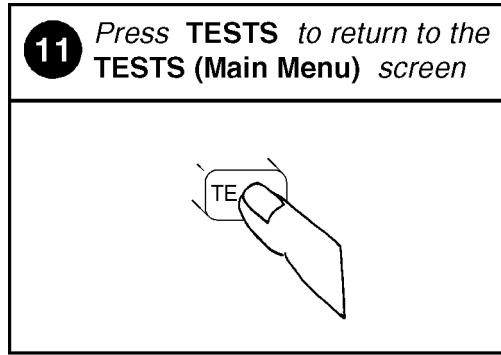

SEQ3

## Specifying Channel Information

For each channel that you wish to specify, you must enter the following information into the **Channel Information** screen: For each channel that you wish to specify, you must enter the following information into the **Channel Information** screen:

- RX Freq (MHz)
  - Enter the receive frequency of your radio in (MHz).
- TX Freq (MHz)
  - Enter the transmit frequency of your radio in (MHz).

---

**NOTE:** Enter a -1 in the RX or TX test frequency fields to have all subsequent frequencies ignored when testing is started.

---

- Sq Freq/Code (for RX Freq) (optional, for testing multiple conventional channels only)
  - enter squelch type and tones/codes.
  - examples: CTFR100 CD023 CT1Z
- Sq Freq/Code (for TX Freq) (optional, for testing multiple conventional channels only)
  - enter squelch type and tones/codes.
  - examples: CTFR100 CD023 CT1Z
- **Test?** (yes/no) specifies whether you want to test the UUT at this channel. If set to “No” then the UUT will not be tested at that channel, but you may retain the channel information in the table for later use. If set to “Yes” then the channel will be used as defined by settings of **Prime?** and **All Chans?** fields.
- **Prime?** (yes/no) specifies which channels are “prime”. Select “Yes” if you want to test the UUT at this channel on all the tests in the procedure. Select **No** if you want to test the UUT at this channel on just a subset of tests, which are designated by selecting **Yes** in the **All Chans** field of the **Order of Tests** screen. See **All Chans?** in **"Changing the Order of Tests" on page 86** for more information.

For information on saving the channel information table, see **"Saving a Test Procedure" on page 102**.

The first 25 channel numbers (1-25) on this screen correspond to the control and working channel numbers for your *trunked* system. You select the control or working channel number (**Chan#**) on this screen, and then enter the *mobile's* corresponding channel receive and transmit frequencies.

Channel numbers 26-50 (**Chan#**) shown on this screen correspond to conventional channels, but are *not* the same as the official FCC assigned channel numbers used to program your radio. They are arbitrary numbers which you define, and should keep record of.

The **All Chans** field in the **Order of Tests** screen interacts closely with the **Prime?** field on the **Channel Information** screen. When the software runs, it begins by retrieving the first channel entered into the **Channel Information** screen. It then checks the response in the **Test?** field to determine if the UUT should be tested at that channel at this time. If there is a **No** response in the **Test?** field, the software will go to the next channel in the table. If there is a **Yes** response in the **Test?** field, the software will check if the channel is **Prime**.

A **Yes** response in the **Prime?** field indicates to test the UUT at that channel on the entire sequence of tests in the procedure. A **No** response in the **Prime?** field indicates to test the UUT at that channel on a subset of tests in the procedure. The subset of tests is determined by a **Yes** response in the **All Chans?** field. Therefore, tests with a **No** response in the **All Chans?** field will be run on *prime* channels only.

Below is an example of how the software would run if you had a procedure set up as follows:

<b>Chan #</b>	<b>Test?</b>	<b>Prime?</b>
Chan 01	Yes	Yes
Chan 02	Yes	No
Chan 03	No	No

<b>Test Number</b>	<b>All Chan? Setting</b>
Test 01	No
Test 02	Yes
Test 03	Yes
Test 04	No











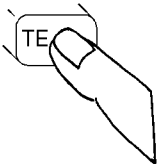

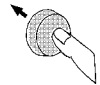

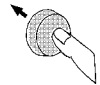

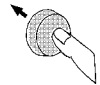

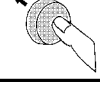

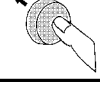

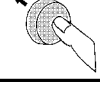



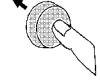

The result would be:

- Chan 01 is used in Test 01, Test 02, Test 03, and Test 04.
- Chan 02 is used in Test 02, and Test 03 only.
- Chan 03 is not used.

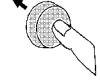
The following table shows how to properly configure these settings according to your testing needs.

<b>Testing Need</b>	<b>Necessary Field Settings</b>		
	<b>Test?</b>	<b>Prime?</b>	<b>All Chan?</b>
Test channel on all tests in sequence	Yes	Yes	Don't Care
Test channel on a subset of tests in sequence	Yes	No	Yes on tests you want included in the testing subset
Do not test this channel now, but retain information for later use	No	Don't Care	Don't Care

## How to Specify Channel Information

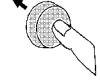
<p><b>1</b> Press <b>TESTS</b> to display the <b>TESTS (Main Menu)</b> screen.</p> <p><i>IF you are in IBASIC, press <b>SHIFT, CANCEL</b> before pressing <b>TESTS</b>.</i></p> 	<p><b>2</b> Position cursor and select <b>Freq Channel Information</b>.</p> <table border="1"> <tr> <td><b>Position</b></td> <td></td> </tr> <tr> <td></td> <td><b>Freq</b> Channel Information</td> </tr> <tr> <td></td> <td><b>Parm</b> Test Parameters</td> </tr> <tr> <td></td> <td><b>Seqn</b> Order of Tests</td> </tr> <tr> <td></td> <td><b>Spec</b> Pass Fail Limits</td> </tr> <tr> <td><b>Select</b></td> <td><b>Proc</b> Save/Delete Procedure</td> </tr> <tr> <td></td> <td></td> </tr> </table>	<b>Position</b>			<b>Freq</b> Channel Information		<b>Parm</b> Test Parameters		<b>Seqn</b> Order of Tests		<b>Spec</b> Pass Fail Limits	<b>Select</b>	<b>Proc</b> Save/Delete Procedure						
<b>Position</b>																			
	<b>Freq</b> Channel Information																		
	<b>Parm</b> Test Parameters																		
	<b>Seqn</b> Order of Tests																		
	<b>Spec</b> Pass Fail Limits																		
<b>Select</b>	<b>Proc</b> Save/Delete Procedure																		
																			
<p>The Channel Information screen is now present on your CRT.</p>	<p><b>3</b> Position cursor and select <b>Chan #</b> field.</p> <table border="1"> <tr> <td><b>Position</b></td> <td></td> </tr> <tr> <td></td> <td>(Disregard this number.)</td> </tr> <tr> <td></td> <td><b>1</b></td> </tr> <tr> <td><b>Select</b></td> <td></td> </tr> <tr> <td></td> <td></td> </tr> </table>	<b>Position</b>			(Disregard this number.)		<b>1</b>	<b>Select</b>											
<b>Position</b>																			
	(Disregard this number.)																		
	<b>1</b>																		
<b>Select</b>																			
																			
<p><b>4</b> Scroll to and select desired <b>Chan #</b>.</p> <table border="1"> <tr> <td><b>Scroll</b></td> <td></td> </tr> <tr> <td></td> <td>(This numbers are examples.)</td> </tr> <tr> <td></td> <td><b>6</b> 0.00000000</td> </tr> <tr> <td><b>Select</b></td> <td></td> </tr> <tr> <td></td> <td></td> </tr> </table>	<b>Scroll</b>			(This numbers are examples.)		<b>6</b> 0.00000000	<b>Select</b>				<p><b>5</b> Position cursor and select <b>RX Freq (MHz)</b> field.</p> <table border="1"> <tr> <td><b>Position</b></td> <td></td> </tr> <tr> <td></td> <td><b>6</b> 0.000000</td> </tr> <tr> <td><b>Select</b></td> <td></td> </tr> <tr> <td></td> <td></td> </tr> </table>	<b>Position</b>			<b>6</b> 0.000000	<b>Select</b>			
<b>Scroll</b>																			
	(This numbers are examples.)																		
	<b>6</b> 0.00000000																		
<b>Select</b>																			
																			
<b>Position</b>																			
	<b>6</b> 0.000000																		
<b>Select</b>																			
																			



FREQ1

Continue on next page

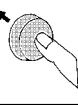

**6** Use **DATA** keys to enter new RX Freq, then select it.

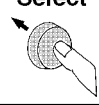
<p><b>Enter</b></p>  <p><b>Select</b></p> 	<div style="border: 1px solid black; padding: 2px; display: inline-block;">6</div> <div style="border: 1px solid black; padding: 2px; display: inline-block; margin-left: 20px;">"New #"</div> <p>(Enter your desired RX Freq)</p>
--	--

**7** Position cursor and select TX Freq (MHz) field.



<p><b>Position</b></p>  <p><b>Select</b></p> 	<div style="border: 1px solid black; padding: 2px; display: inline-block;">#####</div> <div style="border: 1px solid black; padding: 2px; display: inline-block; margin-left: 20px;">0.000000</div> 
---	---

**8** Use **DATA** keys to enter new TX Freq, then select it.

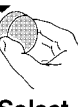

<p><b>Enter</b></p>  <p><b>Select</b></p> 	<div style="border: 1px solid black; padding: 2px; display: inline-block;">#####</div> <div style="border: 1px solid black; padding: 2px; display: inline-block; margin-left: 20px;">"New #"</div> <p>(Enter your desired TX Freq)</p>
---	--

If you are testing receiver/transmitter CTCSS or CDCSS do steps 9 - 12 to enter the receive/transmitt squelch frequency or codes, otherwise continue instructions at step 13.

**9** Position cursor and select Sq Freq/Code field.











<p><b>Position</b></p>  <p><b>Select</b></p> 	<div style="border: 1px solid black; padding: 2px; display: inline-block;">6</div> <div style="border: 1px solid black; padding: 2px; display: inline-block; margin-left: 20px;">#.#####</div> 
---	--

**10** Use **DATA** keys to enter new Sq Freq/Code, then select it.

<p><b>Enter</b></p>  <p><b>Select</b></p> 	<div style="border: 1px solid black; padding: 2px; display: inline-block;">6</div> <div style="border: 1px solid black; padding: 2px; display: inline-block; margin-left: 20px;">#.##### "New #"</div> <p>(Enter your desired Sq Freq/Code)</p>
--	---

Continue on next page

FREQ2

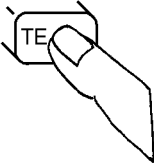
<p><b>11</b> Position cursor and select Sq Freq/Code field.</p>	<p><b>12</b> Use <b>DATA</b> keys to enter new Sq Freq/Code, then select it.</p>
<p><b>Position</b></p>  <p><b>Select</b></p>  <p>##### #.#####</p> 	<p><b>Enter</b></p>  <p><b>Select</b></p>  <p>##### #.##### "New #"</p> <p>(Enter your desired Sq Freq/Code.)</p>
<p><b>13</b> Position cursor at <b>Test?</b> field and select <b>Yes</b> or <b>No</b>.</p>	<p><b>14</b> Position cursor at <b>Prime?</b> field and select <b>Yes</b> or <b>No</b>.</p>
<p><b>Position</b></p>  <p><b>Select</b></p>  <p>Yes/No</p>  <p>(Press knob to change the selection.)</p>	<p><b>Position</b></p>  <p><b>Select</b></p>  <p>Yes/No</p>  <p>(Press knob to change the selection.)</p>
<p><b>15</b> Press <b>TESTS</b> to return to the <b>TESTS (Main Menu)</b> screen.</p>	
	

FREQ3



## Changing Pass/Fail Limits

Pass/Fail limits define the values a measurement's result is compared against to determine if the UUT meets its specified standards. Default values are set in the test software. These default values may be changed to suit your particular requirements.





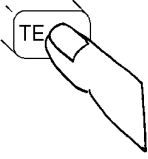
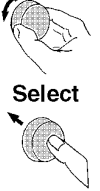
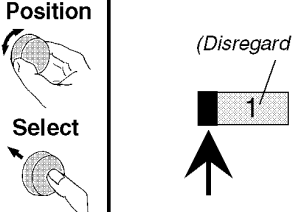











The following describes how to change the pass/fail (upper and lower) limits. See "[Pass/Fail Limit \(Specification\) Descriptions](#)" on page 214 in [chapter 7](#) for descriptions of each pass/fail limit. For information on saving customized pass/fail limits, see "[Saving a Test Procedure](#)" on page 102.

### How to Change Pass/Fail Limits

<p><b>1</b> Press <b>TESTS</b> to display the <b>TESTS</b> screen.</p> <p><i>IF you are in IBASIC, press SHIFT, CANCEL before pressing TESTS.</i></p> 	<p><b>2</b> Position cursor and select <b>Spec Pass Fail Limits</b>.</p> <table border="1"> <tr> <td>Position</td> <td>Freq</td> <td>Channel Information</td> </tr> <tr> <td></td> <td>Parm</td> <td>Test Parameters</td> </tr> <tr> <td></td> <td>Seqn</td> <td>Order of Tests</td> </tr> <tr> <td>Select</td> <td>Spec</td> <td>Pass Fail Limits</td> </tr> <tr> <td></td> <td>Proc</td> <td>Save/Delete Procedure</td> </tr> </table> 	Position	Freq	Channel Information		Parm	Test Parameters		Seqn	Order of Tests	Select	Spec	Pass Fail Limits		Proc	Save/Delete Procedure
Position	Freq	Channel Information														
	Parm	Test Parameters														
	Seqn	Order of Tests														
Select	Spec	Pass Fail Limits														
	Proc	Save/Delete Procedure														
<p>The Pass Fail Limits screen is now present on your CRT.</p>	<p><b>3</b> Position cursor and select <b>Spec #</b> field.</p> <p>(Disregard this number.)</p> 															



SPEC1

Continue on next page

<p><b>4</b> Scroll to and select desired Spec #.</p>	<p><b>5</b> Position cursor and select Lower limit field.</p>
<p><b>Scroll</b>    <b>Select</b>  </p> <p>(This Spec # is an example.)</p> <p>6 FCC TX output p          -1.000000 1.</p> <p></p>	<p><b>Position</b>    <b>Select</b>  </p> <p>6 FCC TX output p          -1.000000 1.</p> <p></p>
<p><b>6</b> Use DATA keys to enter new value, then select it.</p>	<p><b>7</b> Position cursor and select Upper Limit field.</p>
<p><b>Enter</b>    <b>Select</b>  </p> <p>6 FCC TX output p          -0.500000 1.</p> <p>(Enter your desired value.)</p>	<p><b>Position</b>    <b>Select</b>  </p> <p>C TX output power adjustme          .500000 1.000000 dB</p> <p></p>
<p><b>8</b> Use DATA keys to enter new value, then select it.</p>	<p><b>9</b> Position cursor and select Check field.</p>
<p><b>Enter</b>    <b>Select</b>  </p> <p>C TX output power adjustme          500000 0.500000 dB</p> <p>(Enter your desired value.)</p>	<p><b>Position</b>    <b>Select</b>  </p> <p>Both</p> <p></p>

SPEC2

Continue on next page

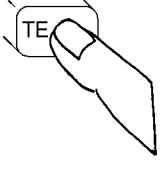
<b>10</b> <i>Position cursor and select Both .</i>		<b>11</b> <i>Press TESTS to return to the TESTS (Main Menu) screen.</i>	
<p><b>Position</b></p> 		<p><b>Select</b></p> 	<p>Choices :</p> <ul style="list-style-type: none"><li>Upper</li><li>Lower</li><li><input checked="" type="checkbox"/> Both</li><li>None</li></ul>
			







SPEC3

## Changing the Test Parameters

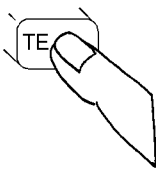
The software uses parameters to optimize the test environment and conditions for your testing situation. Many of the test parameters are determined by examining your test needs. The software comes with default settings for test parameters. Review the defaults for your particular needs. See "[Parameters Descriptions](#)" on [page 207](#) in [chapter 7](#) for descriptions of each test parameter. For information on saving customized test parameters, see "[Saving a Test Procedure](#)" on [page 102](#).

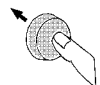

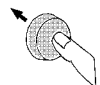

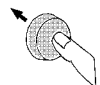







The following describes how you can change test parameters through the Test Parameter screen to optimize your testing conditions.

### How to Change the Test Environment and Conditions

<p><b>1</b> Press <b>TESTS</b> to display the <b>TESTS (Main Menu)</b> screen.</p>	<p><b>2</b> Position cursor and select <b>Parm</b> Test Parameters.</p>														
<p>If you are in IBASIC, press <b>SHIFT, CANCEL</b> before pressing <b>TESTS</b>.</p> 	<table border="1"><tr><td data-bbox="803 955 917 1060"><p><b>Position</b></p></td><td data-bbox="950 997 1274 1144"><table border="1"><tr><td>Freq</td><td>Channel Information</td></tr><tr><td><b>Parm</b></td><td>Test Parameters</td></tr><tr><td>Seqn</td><td>Order of Tests</td></tr><tr><td>Spec</td><td>Pass Fail Limits</td></tr><tr><td>Proc</td><td>Save/Delete Procedure</td></tr></table></td></tr><tr><td data-bbox="803 1071 917 1186"><p><b>Select</b></p></td><td></td></tr></table>	<p><b>Position</b></p> 	<table border="1"><tr><td>Freq</td><td>Channel Information</td></tr><tr><td><b>Parm</b></td><td>Test Parameters</td></tr><tr><td>Seqn</td><td>Order of Tests</td></tr><tr><td>Spec</td><td>Pass Fail Limits</td></tr><tr><td>Proc</td><td>Save/Delete Procedure</td></tr></table>	Freq	Channel Information	<b>Parm</b>	Test Parameters	Seqn	Order of Tests	Spec	Pass Fail Limits	Proc	Save/Delete Procedure	<p><b>Select</b></p> 	
<p><b>Position</b></p> 	<table border="1"><tr><td>Freq</td><td>Channel Information</td></tr><tr><td><b>Parm</b></td><td>Test Parameters</td></tr><tr><td>Seqn</td><td>Order of Tests</td></tr><tr><td>Spec</td><td>Pass Fail Limits</td></tr><tr><td>Proc</td><td>Save/Delete Procedure</td></tr></table>	Freq	Channel Information	<b>Parm</b>	Test Parameters	Seqn	Order of Tests	Spec	Pass Fail Limits	Proc	Save/Delete Procedure				
Freq	Channel Information														
<b>Parm</b>	Test Parameters														
Seqn	Order of Tests														
Spec	Pass Fail Limits														
Proc	Save/Delete Procedure														
<p><b>Select</b></p> 															

PARM1

Continue on next page

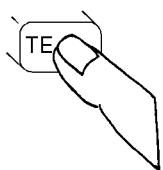
<p>The Tests Parameters screen is now present on your CRT.</p>	
<p><b>3</b> Position cursor and select <b>Parm #</b> field.</p>	
<p><b>Position</b></p>  <p><b>Select</b></p> 	<p>(Entries on your display may be different.)</p> <p>█ 1 RT audio test to          0.000000</p> 
<p><b>4</b> Scroll to and select <b>Parm #</b> to be changed.</p>	
<p><b>Scroll</b></p>  <p><b>Select</b></p> 	<p>(This parameter number and description are examples.)</p> <p>█ 15 TX cable loss</p> 
<p><b>5</b> Position cursor and select <b>Value</b> field.</p>	
<p><b>Position</b></p>  <p><b>Select</b></p> 	<p>█ 15 TX cable loss</p> <p>█ 0.000000</p> 
<p><b>6</b> Use <b>DATA</b> keys to enter new value, then select it.</p>	
<p><b>Enter</b></p>  <p><b>Select</b></p> 	<p>█ 15 TX cable loss</p> <p>█ 1.000000</p>  <p>(Enter your desired value.)</p>
<p><b>7</b> Press <b>TESTS</b> to return to the <b>TESTS (Main Menu)</b> screen.</p>	
	

PAPM2











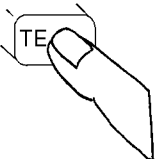







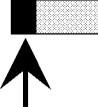

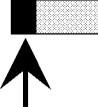
## Saving a Test Procedure

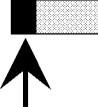
A Test Procedure is a collection of channel information, test parameters, testing order, and pass/fail limits saved in a file that customizes the test software to a specific application. You may save the file to a memory card or disk.

When you save a procedure you will be saving channel information, test parameters, pass/fail limits, and testing order, plus a library that contains the names of all test parameters, pass/fail limits, and tests that are resident in the software. The library file comes from the software and cannot be modified. The library file will be automatically saved on the card or disk that is being used to store the new test procedure.

The following example shows how to save a new procedure to a memory card. For more information concerning procedures, see "[Procedures](#)" on page 269 in [chapter 8, "Reference \(Alphabetical\)"](#).

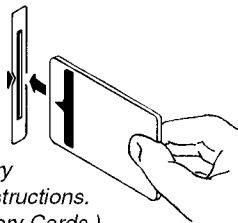

## How to Save a Test Procedure



<p><b>1</b> Press <b>TESTS</b> to display the <b>TESTS (Main Menu)</b> screen.</p>	<p><b>2</b> Position cursor and select <b>Proc Save/Delete Prodedure.</b></p>															
<p>If you are in <b>IBASIC</b>, press <b>SHIFT, CANCEL</b> before pressing <b>TESTS</b>.</p> 	<table border="1"> <tr> <td><b>Position</b></td> <td></td> <td><b>Freq</b> Channel Information</td> </tr> <tr> <td></td> <td></td> <td><b>Parm</b> Test Parameters</td> </tr> <tr> <td></td> <td></td> <td><b>Seqn</b> Order of Tests</td> </tr> <tr> <td></td> <td></td> <td><b>Spec</b> Pass Fail Limits</td> </tr> <tr> <td><b>Select</b></td> <td></td> <td><b>Proc</b> Save/Delete Procedure</td> </tr> </table>	<b>Position</b>		<b>Freq</b> Channel Information			<b>Parm</b> Test Parameters			<b>Seqn</b> Order of Tests			<b>Spec</b> Pass Fail Limits	<b>Select</b>		<b>Proc</b> Save/Delete Procedure
<b>Position</b>		<b>Freq</b> Channel Information														
		<b>Parm</b> Test Parameters														
		<b>Seqn</b> Order of Tests														
		<b>Spec</b> Pass Fail Limits														
<b>Select</b>		<b>Proc</b> Save/Delete Procedure														
<p>The <b>Save/Delete Procedure</b> screen is now present on your CRT.</p>	<p><b>3</b> Position cursor and select <b>Select Procedure Location.</b></p> <table border="1"> <tr> <td><b>Position</b></td> <td></td> <td>Select Procedure Location:</td> </tr> <tr> <td></td> <td></td> <td></td> </tr> <tr> <td><b>Select</b></td> <td></td> <td></td> </tr> </table>	<b>Position</b>		Select Procedure Location:				<b>Select</b>								
<b>Position</b>		Select Procedure Location:														
																
<b>Select</b>																
<p><b>4</b> Position cursor and select <b>Card.</b></p>	<p><b>5</b> Insert an initialized <b>SRAM</b> memory card.</p>															
<table border="1"> <tr> <td><b>Position</b></td> <td></td> <td>Choices :</td> </tr> <tr> <td></td> <td></td> <td><input checked="" type="checkbox"/> Card</td> </tr> <tr> <td></td> <td></td> <td><input type="checkbox"/> RAM</td> </tr> <tr> <td></td> <td></td> <td><input type="checkbox"/> Disk</td> </tr> <tr> <td><b>Select</b></td> <td></td> <td></td> </tr> </table> <p>(You can also save procedures to an internal RAM disk or external disk drive. See chapter 4-Disks.)</p>	<b>Position</b>		Choices :			<input checked="" type="checkbox"/> Card			<input type="checkbox"/> RAM			<input type="checkbox"/> Disk	<b>Select</b>			 <p>(For detailed memory card initialization instructions. see chapter 8 -Memory Cards.)</p>
<b>Position</b>		Choices :														
		<input checked="" type="checkbox"/> Card														
		<input type="checkbox"/> RAM														
		<input type="checkbox"/> Disk														
<b>Select</b>																

PROCMA11



Continue on next page

**6** *Position cursor and select*  
**Enter Procedure Filename:.**

**Position**  
  
**Select**  



Enter Procedure Filename:  
  



**7** *Select characters to name the procedure, then select Done.*

**Position**  
  
**Select**  



Choices :  
 Done  
 Position  
 Over/Ins  
 Delete  
 Del End  
 Bk space  
 A  
 B  
 C

**8** *Position cursor and select*  
**Enter Description for new ... .**

**Position**  
  
**Select**  



Enter Description for new ... :  
  



**9** *Select characters for the description, then select Done.*

**Position**  
  
**Select**  



Choices :  
 Done  
 Position  
 Over/Ins  
 Delete  
 Del End  
 Bk space  
 A  
 B  
 C

**10** *Position cursor at Procedure Library: and select Current.*

**Position**  
  
**Select**  





Procedure Library:  
 Current / [NO LIB]  
  
 (The underline indicates which option is selected. Pressing knob changes the selection.)

**11** *Position cursor and select Code Location:.*

Code Location:  
 Card  

Continue on next page



<b>12</b> <i>Position cursor and select Card.</i>	<b>13</b> <i>Position cursor and select Save Proc .</i>
<p><b>Position</b></p>  <p><b>Select</b></p> 	<p><b>Position</b></p>  <p><b>Select</b></p> 
<p>Choices :</p> <ul style="list-style-type: none"><li>■ Card</li><li>RAM</li><li>Disk</li></ul>	<ul style="list-style-type: none"><li>■ Save Proc</li><li>2 Del Proc</li><li>3 Init Card</li><li>4 Help</li><li>5 Main Menu</li></ul>

**14** *Press TESTS to return to the TESTS (Main Tests) screen.*

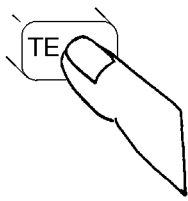

**15** *To run the saved procedure, follow the instructions below.*

- 1) Insert the RAM card with your saved procedure.
- 2) On the **TESTS (Main Menu)** screen, a) position cursor and select **Select Procedure Location:**, then select **Card**. b) position cursor and select **Select Procedure Filename:**, then select your saved file name.)
- 3) Remove your RAM card and insert the original HP 11807A/E ROM memory card.
- 4) Press **Run Test** .

*The original card contains the full program needed to run your procedure.*

PROCMA3a

## Changing Test Execution Conditions

**Test Execution Conditions** define where and when test output occurs. You may decide to:

- Display output on CRT only, or display on CRT and print hardcopy (**Output Results To**).

---

### **NOTE:**

If printing test results is desired, after selecting **Printer**, additional steps are necessary to connect and configure the printer. See "**Printing**" on page 257 in **chapter 8**.

- Display (or print) only measurements that fail, or display (or print) all measurements that pass or fail (**Output Results For**).
- Enter a title for an output heading for the displayed or printed results (**Output Heading**).
- Stop testing when a measurement fails or continue through all of the tests without stopping (**If Unit-Under-Test-Fails**).
- Pause between each measurement, or run through entire test (**Test Procedure Run Mode**).
- Start the program automatically when the Test System is powered on. (**Autostart Test Procedure on Power-up**)

**Test Execution Conditions** is accessed from the **SETUP TEST SET:** list. To change a default setting, position the cursor to the desired field. Pressing the knob ("selecting") will toggle the underlined selection.

**Test Execution Conditions** settings are not retained after a power-down/power-up cycle, and will return to their default settings.

## How to Change Test Execution Conditions

**1** Press **TESTS** to display the **TESTS (Main Menu)** screen.

*If you are in IBASIC, press SHIFT, CANCEL before pressing TESTS.*

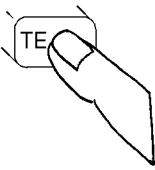

**2** Position cursor at **Exec** **Execution Cond** and select it.

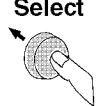
<b>Position</b>		<b>Exec</b> Execution Cond	
		<b>Cnfg</b> External Devices	
		<b>Print</b> Printer Setup	
<b>Select</b>		<b>IBASIC</b> IBASIC Cntrl	

**3**

*Select Printer to output test procedure results to the CRT and a printer.*

*Select Failures to display only the CRT and printer measurements that fail.*

*Select Stop to stop a Test Procedure when a failure occurs.*

*Select Single Step to stop a Test Procedure at the end of each measurement.*

TESTS (Execution Conditions)	
Output Results To:	1 Run Test
<b>Crt/Printer</b>	2 Continue
Output Results For:	4 Help
<b>All/Failures</b>	5 Main Menu
Output Heading:	
	To Screen
	RF GEN
	RF ANL
	AF ANL
	SCOPE
	SPEC ANL
	ENCODER
	DECODER
	RADIO INT
	More
If Unit-Under-Test Fails:	
<b>Continue/Stop</b>	
Test Procedure Run Mode:	
<b>Continuous/Single Step</b>	
Autostart Test Procedure on Power-Up:	
<b>Off/On</b>	

TESTEXEa

107

## Printing and Saving Test Results

Printing and saving test results are features of the software which require additional equipment and configuration. See "[Printing](#)" on page 257 in [chapter 8](#) for detailed descriptions and instructions for these features.

---

**Using the Software/HP 8920A FW Rev.  
Below A.14.00**



---

## Firmware Enhancements

**NOTE:** The firmware revision A.14.00 in the HP 8920A,D had several enhancements, which are standard in the HP 8920B. This chapter applies to users with:

- **HP 8920A test sets with firmware revision below A.14.00**

The test set's firmware revision is displayed on the top right corner of the configuration screen.

- Press SHIFT CONFIG to display the configuration screen and read the firmware revision.

If you have an HP 8920B or an HP 8920A with firmware revision above A.14.00, refer to [chapter 5, "Using the Software/HP 8920B, or HP 8920A FW Above Rev. A.14.00"](#). Contact Hewlett-Packard at 1-800-922-8920 for details on upgrading your firmware if desired.

---

The HP 11807A,E Software can be run on the factory default settings, but usually should be customized to your individual needs and the specific requirements of the radio under test. This chapter provides detailed information on how to load, run, and customize the software.

## What You Should Know Before Using the Software

To properly operate this software, you must understand the manual operation of your radio, and the various configuration information programmed into it. Operating information should be provided in the radio's manual. Programmed information must be provided by the programmer, or by reading the information over a data bus.

To be able to test your radio, you must know:

- Which channels are conventional and which are trunked.
- The transmit and receive frequencies for each channel.
- Conventional radio settings:
  - Squelch type.
  - Squelch tone frequency for CTCSS radios.
  - Squelch code for CDCSS radios.
- Trunked radio settings:
  - Control channel number.
  - Working channel numbers.
  - Site ID.
  - Logical ID (*may instead be read by software in Test\_22, Read UUT*)
  - Group ID (*may instead be read by software in Test\_22, Read UUT*)
  - Call Type
  - Callee ID for individual calls (*may instead be read by software in Test\_22, Read UUT*)



---

## Testing Overview

Pressing TESTS will display what is called the TESTS screen. From this TESTS screen you have the option to:

### Begin running tests:

- The factory default settings are acceptable for your application or
- The software has already been customized for your radio, and saved to an SRAM card

or

### Customize the software:

- Decide which tests you desire to run (Test Sequence)
  - you may want to run all, some, or just one of the tests.
- Specify which channels to test, and enter frequency information (Frequency)
  - the FCC RX and TX frequencies will vary from radio to radio, as well as channel to channel.
  - you may want to test one, some, or all of the channels on your radio.
- Change the pass/fail limits for specific measurements (Specifications)
  - you may want the pass/fail limits to have tighter or looser specifications than the default settings.
- Change the test environment and conditions (Parameters)
  - define if certain values should be measured or calculated.
  - decide output format.
  - enter specific information about the radio and/or test environment.
- Save any or all of the above customized changes (to an SRAM card)
- Select options:
  - Print test results or certain screens.
  - Decide when and where test results are displayed (**Test Execution Conditions**)

## To Run Tests

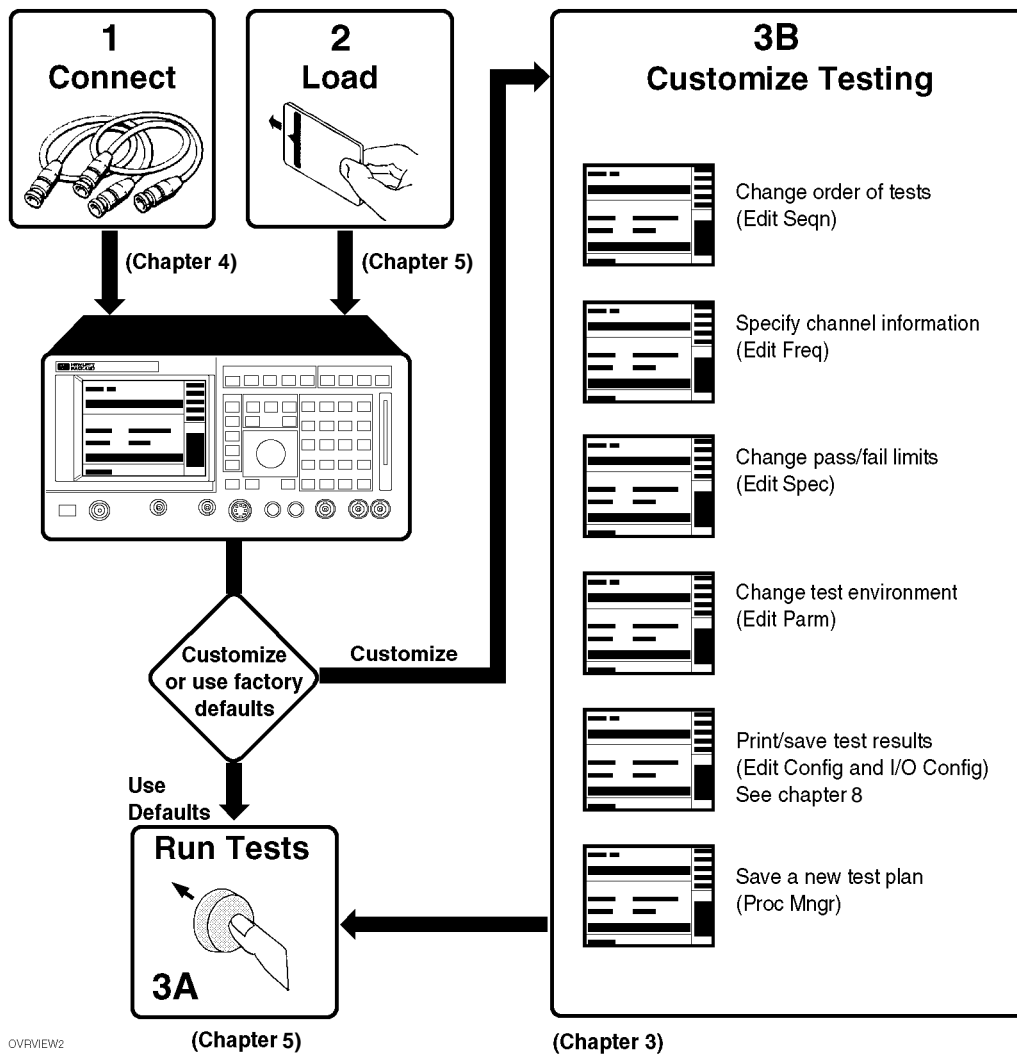

---

## Running Tests

Before you begin to load the software and run tests, you should have made the appropriate hardware connections. See [chapter 4, "Making Connections"](#) if you have not done so already.

The HP 11807A,E Software may be run with its factory default settings, or it may be customized to your specific radio requirements (see ["Customizing Testing" on page 120](#)).

When TESTs begin to run, they are executed in the order in which they were entered into the Test Procedure.

- Pressing CANCEL will pause the current test (press k2 (**Continue**) to continue the test).

## Loading the Software

Before you begin testing, you must load the software into the test set memory. To load the software, you must first select the location to load from (in this case, it will be **Card**) and a procedure filename. Your card comes pre-programmed with at least one procedure. The actual software program does not get loaded into the test set memory until k1 (**Run Test**) is selected. It will take approximately two minutes for the software program to be loaded at that time.

The software memory card can be removed after the program is loaded into the HP 8920A,D memory. The program will remain in memory after a power-down/power-up cycle, unless it is manually deleted or a new program is loaded.

### **Loading a Software Upgrade, FW below rev A.12.04 only**

If you have purchased a software upgrade from the factory and are loading it for the first time, you must clear the old revision software from the test set memory before running the new revision software. If you do not, the new revision will not be loaded, and the old revision will be used. This is for FW below revision A.12.04 only. For firmware revision A.12.04 and above, the test set will check for differences in the code, and automatically load the most updated version.

The easiest way to clear the old revision software is to load a different software program. The LIST\_OPTS program that is stored in internal ROM can be used for this purpose.

**To Load the  
LIST\_OPTS Program:**

1. Press TESTS.
2. Position the cursor to **Select Procedure Location** and select it.
3. From the **Choices** menu, select **ROM**.
4. Position the cursor to **Select Procedure Filename** and select it.
5. From the **Choices** menu, select **LIST\_OPTS**.
6. Press k1 (**Run Test**).

The new revision software can now be loaded.

## Starting Up

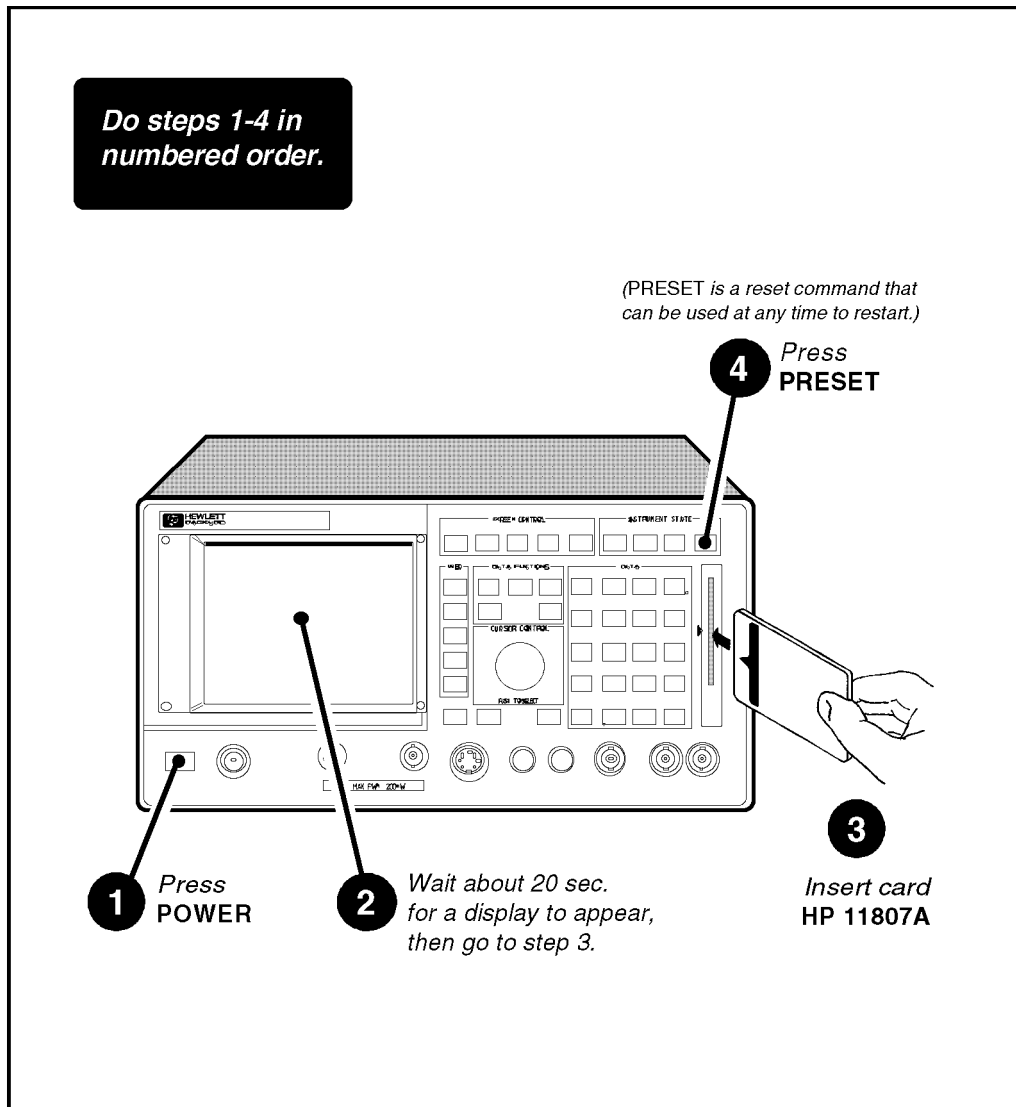

Continue on next page

**5** Press **TESTS** to display the **TESTS** screen.

If you are in **IBASIC**, press **SHIFT, CANCEL** before pressing **TESTS**.

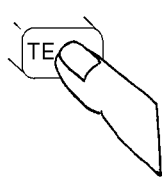

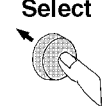
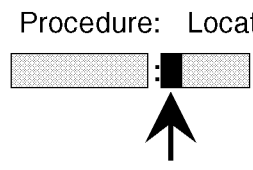

**6** Position cursor at **Location** and select it.

**Position**  Procedure: Location

**Select**  

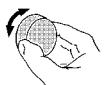
**7** Position cursor at **Card** and select it.

**Position**  Choices :

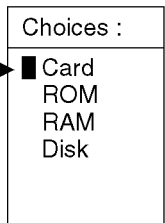
**Select**  

**8** Position cursor at **Procedure** and select it.

**Position**  Procedure: Location

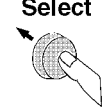
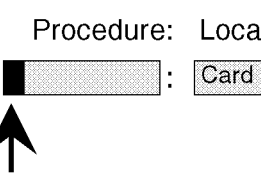

**Select**  

**9** Position cursor at the desired **Procedure** and select it.

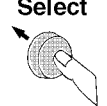
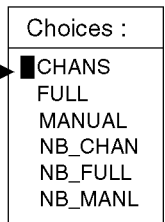
**Position**  Choices :

**Select**  

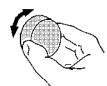
**10** Position cursor at **RUN TEST** and select it.

**Position**  

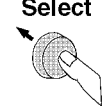
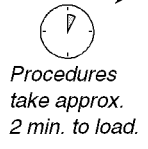
**Select**  

PRO1

---

## Customizing Testing

The HP 11807A,E Software may need some customizing before it performs in a way that is necessary for your testing needs. Because of the diversity of individual testing needs, the HP 11807A,E Software has been designed so that changes may be easily made from the HP 8920A,D front panel. You may store these changes on an SRAM card so that you may skip these steps in the future. See "[Saving a Test Procedure \(Procedure Manager\)](#)" on page 140.

You may customize your software at any time. Because your needs change, the software allows changes to its default settings when you need to make them and in any order that you choose. For example, tests may be inserted or deleted, and later after running the tests you can change the pass/fail limits or decide to test different channels.

Most screens. These Test Function screens are accessed from the main TESTS screen as shown in the following figure. All Test Functions are explained in this chapter by function.

---

**NOTE:**

Edit Configuration (Edit Cnfg) and IBASIC will not be explained in this customizing section.

- Edit Configuration is used when setting up printers and external disk drives which is explained in "[Disks](#)" on page 241 and "[Printing](#)" on page 257 in chapter 8.
- IBASIC is used when writing your own programs and is not explained in this manual. If you need to write your own IBASIC programs you may acquire the following manuals:
  - HP 8920A,D
    - *HP Instrument Basic User's Handbook* HP part number E2083-90601.
    - *HP 8920A Programming Manual* HP part number 08920-90220.
  - HP 8920B
    - *HP Instrument Basic User's Handbook Version 2.0* HP part number E2083-90005.
  - *HP 8920B Programming Manual* HP part number 08920-90222.



## How to Customize Testing

**TESTS Screen**

Procedure:	Location	Library	Program
██████████	: Card		:Card

Comment  
██

---

**Test Execution Conditions**

On UUT Failure	Run Mode
Continue/Stop	Continuous/Single Step
Output Results	Output Destination
All/Failures	Art/Printer

Output Heading  
██

Test Function  
Edit Parm

1 Run Test  
2 Continue  
3 Edit Sean  
4 Edit Freq  
5 Edit Spec

Choices:  
Edit Sean  
Edit Freq  
Edit Spec  
Edit Parm  
Edit Cnfg  
Proc Mngr  
IBASIC

Selecting Test Function opens the Test Function Choices menu.

Test Function choices.

CUSTOM1

## Changing a Sequence of Tests (Edit Sequence)







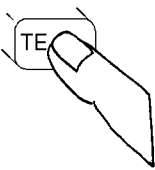

You may define a test sequence to include all, some, or just one of the tests available. When the first test is finished, the next will run. The test sequence will remain in the Test Set's battery backed-up memory until another test sequence is loaded or set up. For information on saving a customized test sequence, see "[Saving a Test Procedure \(Procedure Manager\)](#)" on page 140.

Creation of a test sequence is accomplished by inserting or deleting tests from the list of tests that come with the HP 11807A,E Software package. See [chapter 7, "Test, Parameter, and Pass/Fail Limit \(Specification\) Descriptions"](#) for a tests list and descriptions.

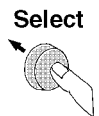
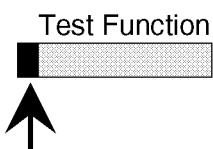
The **All Chans?** field allows the user to decide to run the test on all channels entered in the **Frequency** table, or just the channels which are selected as **Prime** in the **Edit Frequency** screen. This feature allows the user the flexibility to use channels that are selected as **Prime** in all the tests in the sequence, and those indicated as non-prime in a subset of tests (those tests with a **Yes** response in **All Chans**). For more information, see "[Specifying Channel Information \(Edit Frequency\)](#)" on page 126.

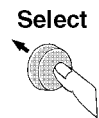
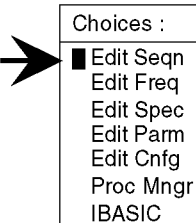

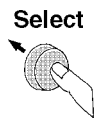
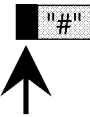

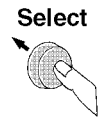
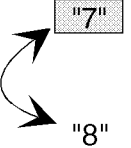





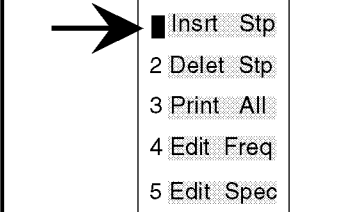

The following describes how to create a new test sequence and enter a response to **All Chans**.

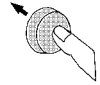
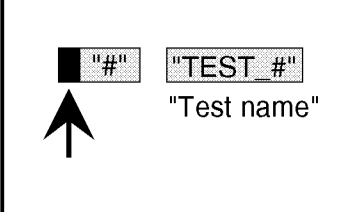
## How to Change a Sequence of Tests

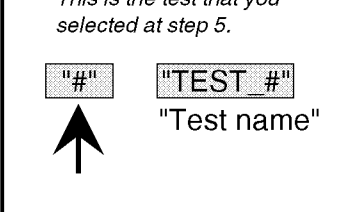
<p><b>1</b> Press <b>TESTS</b> to display the <b>TESTS</b> screen.</p>	<p><b>2</b> Position cursor at <b>Test Function</b> and select it.</p>
<p>If you are in <b>IBASIC</b>, press <b>SHIFT, CANCEL</b> before pressing <b>TESTS</b>.</p> 	<p><b>Position</b></p>  <p><b>Select</b></p>  
<p><b>3</b> Position cursor at <b>Edit Seqn</b> and select it.</p>	<p><b>4</b> Position cursor at <b>Step #</b> field and select it.</p>
<p><b>Position</b></p>  <p><b>Select</b></p>  	<p><b>Position</b></p>  <p><b>Select</b></p>  <p><i>Example</i></p>  <p>"#"</p> <p>"TEST_#"</p> <p>"Test name"</p>
<p><b>5</b> By rotating knob, highlight the <b>Step #</b> which precedes the insertion point of the new test that you are adding, then select it.</p>	
<p><b>Position</b></p>  <p><b>Select</b></p> 	<p><i>For example, select step 7 if you want to insert the new test as step 8.</i></p>  <p>"7"</p> <p>"TEST_#"</p> <p>"Test name"</p> <p>"8"</p> <p>"New test"</p>

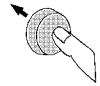
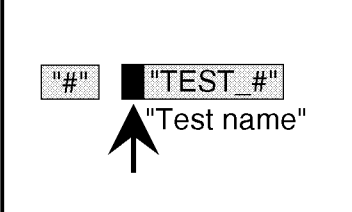
SEQ3-1

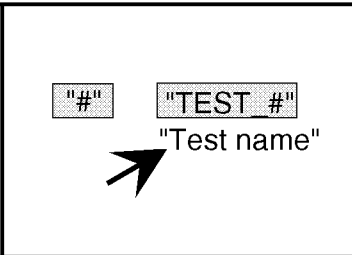
Continue on next page

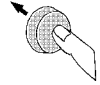
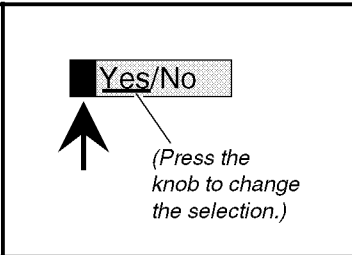
<p><b>6</b> Position cursor at <b>Insrt Stp</b> and select it.</p>	<p><b>7</b> Position cursor back at <b>Step #</b> field and select it.</p>
<p><b>Position</b></p>  <p><b>Select</b></p>  	<p><b>Position</b></p>  <p><b>Select</b></p>  
<p><b>8</b> Highlight <b>Step #</b> of the newly inserted test, then select it.</p>	<p><b>9</b> Position cursor at <b>Test name</b> field and select it.</p>
<p><b>Position</b></p>  <p><b>Select</b></p>  <p>This is the test that you selected at step 5.</p> 	<p><b>Position</b></p>  <p><b>Select</b></p>  
<p><b>10</b> Rotate knob until desired <b>Test Name</b> appears, then select it</p>	<p><b>11</b> Position cursor at <b>All Chans?</b> field and select <b>Yes</b> or <b>No</b>.</p>
<p><b>Rotate</b></p>  <p><b>Select</b></p>  	<p><b>Position</b></p>  <p><b>Select</b></p>  

SEC9-2

Continue on next page

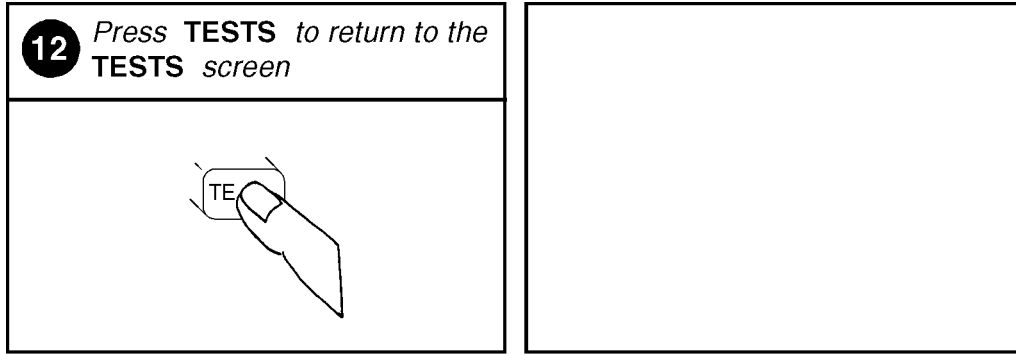

SEQ3

## Specifying Channel Information (Edit Frequency)

For each channel number, you must enter the following information:

- RX frequency
  - enter the channel receive frequency in MHz
- TX frequency
  - enter the channel transmit frequency in MHz
- **Test?** (yes/no) specifies whether you want to test the UUT at this channel. If set to “No” then the UUT will not be tested at that channel, but you may retain the channel information in the table for later use. If set to “Yes” then the channel will be used as defined by settings of **Prime?** and **All Chans?** fields.
- **Prime?** (yes/no) specifies which channels are “prime”. Select “Yes” if you want to test the UUT at this channel on all the tests in the procedure. Select **No** if you want to test the UUT at this channel on just a subset of tests, which are designated by selecting **Yes** in the **All Chans** field of the **Order of Tests** screen. See **All Chans?** in "[Changing a Sequence of Tests \(Edit Sequence\)](#)" on page 122 for more information.

\*Channel Info (optional, for testing multiple conventional channels only)

- enter squelch type and tones/codes.
- examples: CTFR100 CD023 CT1Z

The first 25 channel numbers (1-25) on this screen correspond to the control and working channel numbers for your **trunked** system. You select the control or working channel number (**Chan#**) on this screen, and then enter the *mobile's* corresponding channel receive and transmit frequencies.

Channel numbers 26-50 (**Chan#**) shown on this screen correspond to conventional channels, but are *not* the same as the official FCC assigned channel numbers used to program your radio. They are arbitrary numbers which you define, and should keep record of.

For information on saving the frequency table, see "[Saving a Test Procedure \(Procedure Manager\)](#)" on page 140.

The **All Chans** field in the Edit Sequence screen interacts closely with the **Prime?** field on the Edit Frequency screen. When the software runs, it begins by retrieving the first channel entered into the Edit Frequency screen. It then checks the response in the **Test?** field to determine if the UUT should be tested at that channel at this time. If there is a **No** response in the **Test?** field, the software will go to the next channel in the table. If there is a **Yes** response in the **Test?** field, the software will check if the channel is **Prime**.

A **Yes** response in the **Prime?** field indicates to test the UUT at that channel on the entire sequence of tests in the procedure. A **No** response in the **Prime?** field indicates to test the UUT at that channel on a subset of tests in the procedure. The subset of tests is determined by a **Yes** response in the **All Chans?** field. Therefore, tests with a **No** response in the **All Chans?** field will be run on *prime* channels only.

Below is an example of how the software would run if you had a procedure set up as follows:

<b>Chan #</b>	<b>Test?</b>	<b>Prime?</b>
Chan 01	Yes	Yes
Chan 02	Yes	No
Chan 03	No	No

<b>Test Number</b>	<b>All Chan? Setting</b>
Test 01	No
Test 02	Yes
Test 03	Yes
Test 04	No

The result would be:







- Chan 01 is used in Test 01, Test 02, Test 03, and Test 04.
- Chan 02 is used in Test 02, and Test 03 only.
- Chan 03 is not used.

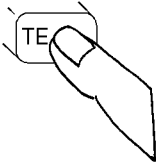

The following table shows how to properly configure these settings according to your testing needs.

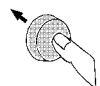
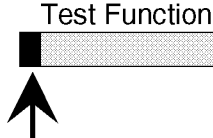
Testing Need	Necessary Field Settings		
	Test?	Prime?	All Chan?
Test channel on all tests in sequence	Yes	Yes	Don't Care
Test channel on a subset of tests in sequence	Yes	No	Yes on tests you want included in the testing subset
Do not test this channel now, but retain information for later use	No	Don't Care	Don't Care

### How to Specify Channel Information

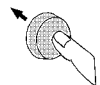
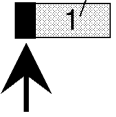
<p><b>1</b> Press <b>TESTS</b> to display the <b>TESTS</b> screen.</p>	<p><b>2</b> Position cursor at <b>Test Function</b> and select it.</p>
<p><i>IF you're in IBASIC, press <b>SHIFT, CANCEL</b> before pressing <b>TESTS</b>.</i></p> 	<p><b>Position</b></p>  <p><b>Select</b></p>  <p>Test Function</p> 
<p><b>3</b> Position cursor at <b>Edit Freq</b> and select it.</p>	<p><b>4</b> Position cursor at <b>Chan #</b> field and select it.</p>
<p><b>Position</b></p>  <p><b>Select</b></p>  <p>Choices :</p> <ul style="list-style-type: none"> <li>■ Edit Seqn</li> <li>■ Edit Freq</li> <li>■ Edit Spec</li> <li>■ Edit Parm</li> <li>■ Edit Cnfg</li> <li>■ Proc Mngr</li> <li>■ IBASIC</li> </ul>	<p><b>Position</b></p>  <p><b>Select</b></p>  <p>(Disregard this number)</p> 

FREQ01

Continue on next page

**5** Scroll to the desired **Chan #** and select it.

**Position**  (This **Chan #** is an example)

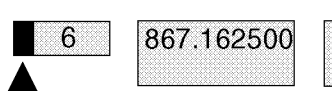

**Select**  

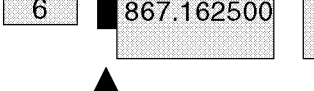
**6** Position cursor at **RX Freq** field and select it.

**Position**  

**Select** 

**7** Use **DATA** keys to enter new value, then select it.

**Position**  

**Select**  (enter your desired value)

**8** Position cursor at **TX Freq** field and select it.

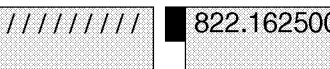
**Position**  

**Select** 

**9** Use **DATA** keys to enter new value, then select it.

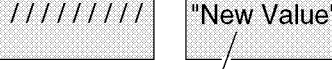
**Position**  

**Select**  (enter your desired value)



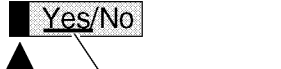







**10** Position cursor at **Test?** field and select **Yes** or **No**.

**Position**  

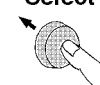
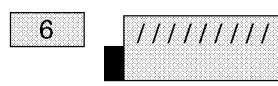
**Select**  (Pressing the knob changes the selection.)

FREC2

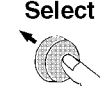
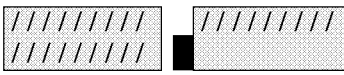
Continue on next page

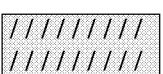
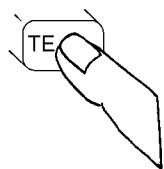
<p><b>11</b> Position cursor at <b>Prime?</b> field and select <b>Yes</b> or <b>No</b>.</p> <p><b>Position</b>  </p> <p><b>Select</b>  </p> <p><b>Yes/No</b>            (Press knob to change the selection)</p>	<p><b>12</b> Position cursor at <b>RX Chan info</b> field and select it.</p> <p><b>Position</b>  </p> <p><b>Select</b>  </p> <p>6           (conventional channels only)</p>
<p><b>13</b> Use <b>DATA</b> keys to enter new value, then select it.</p> <p><b>Position</b>  </p> <p><b>Select</b>  </p> <p>6           "New Info"          (Enter your <i>RX Chan Info</i>)</p>	<p><b>14</b> Position cursor at <b>TX Chan info</b> field and select it.</p> <p><b>Position</b>  </p> <p><b>Select</b>  </p> <p></p>
<p><b>15</b> Use <b>DATA</b> keys to enter new value, then select it.</p> <p><b>Position</b>  </p> <p><b>Select</b>  </p> <p>          "New Info"          (Enter your <i>TX Chan Info</i>)</p>	<p><b>16</b> Press <b>TESTS</b> to return to the <b>TESTS</b> screen.</p> <p></p>







FREQ3

## Changing Pass/Fail Limits (Edit Specifications)

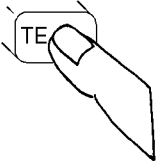
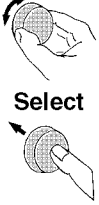
Specifications are used to set pass/fail limits for tests. Default values are available in the test software. These default values may be changed to suit your particular requirements.

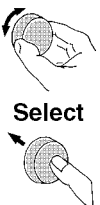
The following describes how to change the pass/fail (upper and lower) limits in the HP 8920A,D “Edit Specification” screen. See ["Pass/Fail Limits \(Specifications\)" on page 214 in chapter 7](#) for descriptions and default values for each specification. For information on saving customized specifications, see ["Saving a Test Procedure \(Procedure Manager\)" on page 140](#).

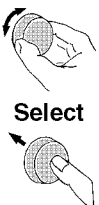
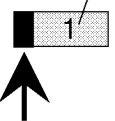
### How to Change Pass/Fail Limits



<p><b>1</b> Press <b>TESTS</b> to display the <b>TESTS</b> screen.</p>	<p><b>2</b> Position cursor at <b>Test Function</b> and select it.</p>								
<p><i>IF you're in IBASIC, press <b>SHIFT, CANCEL</b> before pressing <b>TESTS</b>.</i></p> 	<p><b>Position</b></p>  <p><b>Select</b></p> 								
<p><b>3</b> Position cursor at <b>Edit Spec</b> and select it.</p>	<p><b>4</b> Position cursor at <b>Spec #</b> field and select it.</p>								
<p><b>Position</b></p>  <p><b>Select</b></p>  <table border="1" data-bbox="613 1360 748 1583"> <tr><td>Choices :</td></tr> <tr><td>Edit Seqn</td></tr> <tr><td>Edit Freq</td></tr> <tr><td>■ Edit Spec</td></tr> <tr><td>Edit Parm</td></tr> <tr><td>Edit Cnfg</td></tr> <tr><td>Proc Mngr</td></tr> <tr><td>IBASIC</td></tr> </table>	Choices :	Edit Seqn	Edit Freq	■ Edit Spec	Edit Parm	Edit Cnfg	Proc Mngr	IBASIC	<p><b>Position</b></p>  <p><b>Select</b></p>  <p><i>(Disregard this number)</i></p> 
Choices :									
Edit Seqn									
Edit Freq									
■ Edit Spec									
Edit Parm									
Edit Cnfg									
Proc Mngr									
IBASIC									

SPEC3-1

Continue on next page

**5** Scroll to the desired **Spec #** and select it.



**Position**  (This Spec # is an example)

**Select**  

6 RX audio output  
 3.000000 0.

**6** Position cursor at **Lower limit** field and select it.



**Position** 

**Select**  

6 RX audio output  
 3.000000 0.

**7** Use **DATA** keys to enter new value, then select it.



**Position** 

**Select**  

6 RX audio output  
 2.000000 0.  
 (enter your desired value)

**8** Position cursor at **Upper Limit** field and select it.



**Position** 

**Select**  

audio output @40% of full ra  
 0.000000 0.000000 dB

**9** Use **DATA** keys to enter new value, then select it.



**Position** 

**Select**  

audio output @40% of full ra  
 0.000000 4.000000 dB  
 (enter your desired value)

**10** Position cursor at **Check field** and select it.



**Position** 

**Select**  



Both

SPEC3-2

Continue on next page

<b>11</b> Position cursor at <b>Both</b> and select it.	
<b>Position</b> 	<b>Choices :</b> Upper Lower <input checked="" type="checkbox"/> Both None
<b>Select</b> 	

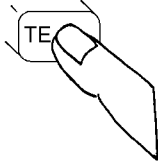
SPEC3

<b>12</b> Press <b>TESTS</b> to return to the <b>TESTS</b> screen.	
<b>Position</b> 	
<b>Select</b> 	

## Changing the Test Environment and Conditions (Edit Parameters)

Parameters are used to optimize the test environment and conditions for your testing situation. Many of the parameters are determined by examining your test needs. Other parameters are determined by performing measurements to calibrate items in your system. Examples of parameters include providing information regarding supply voltage, trunked signaling deviation, audio load impedance, and so forth. The HP 11807A,E Software comes with default settings for parameters. The defaults should be reviewed for your particular needs. See "[Parameters Descriptions](#)" on page 207 in chapter 7 for descriptions and default values for each parameter. For information on saving customized parameters, see "[Saving a Test Procedure \(Procedure Manager\)](#)" on page 140.

The following describes how you can change parameters through the Edit Parameter screen to optimize your testing conditions.

### How to Change the Test Environment and Conditions

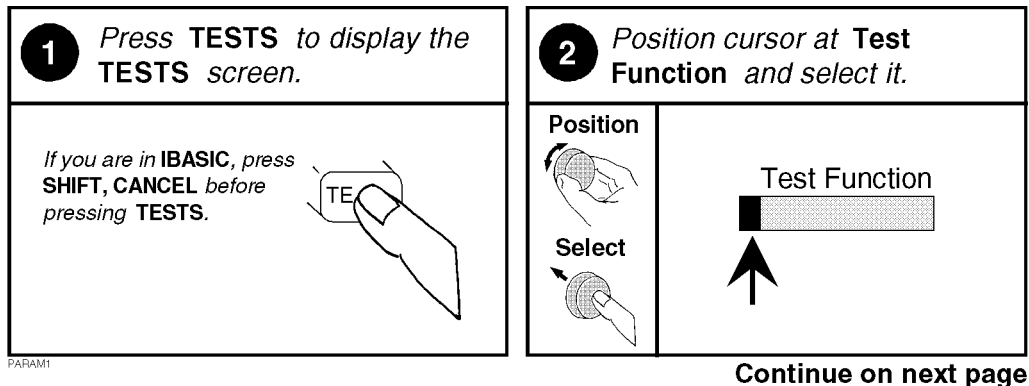



**3** Position cursor at **Edit Parm** and select it.

**Position**  



**Select**  



Choices :

- Edit Seqn
- Edit Freq
- Edit Spec
- Edit Parm
- Edit Cnfg
- Proc Mngr
- IBASIC



**4** Position cursor at **Parm #** field and select it.

**Position**  



**Select**  



(Entries on your display may be different)

1 AA use GN valu  
 1.000000



**5** Scroll to **Parm #** to be changed and select it

**Position**  



**Select**  



(This parameter number and description are examples)

17 GN trunked site ID  
 1.000000



**6** Position cursor at **Value** field and select it.

**Position**  



**Select**  

17 GN trunked site  
 1.000000



**7** Use **DATA** keys to enter new value, and select it.

**Position**  

**Select**  

17 GN trunked site  
 / / / / / / / /



**8** Press **TESTS** to return to the **TESTS** screen.

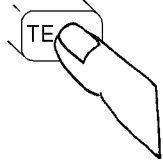

PARAM2

## The System Information Screen

The **System Information Screen** allows quick entry for data which is likely to change between different systems on a given radio. Entering values for parameters into this screen does **not** change their values on the Edit Parameters screen. The System Information Screen is set up to be used with the Full\_Test and Manual procedures (see "**Factory-Defined Procedures and Defaults**" on page 149 in **chapter 7** for descriptions). The All\_Chans procedure must have all parameters edited directly through the Edit Parameter screen. The System Information Screen offers the following choices:

### Trunked Channels

- Begin Testing
  - using entries shown on the System Information Screen, goes directly to the first test in the procedure.
- Working Channel
  - corresponding RX and TX frequencies are displayed
- Control Channel
  - corresponding RX and TX frequencies are displayed
- Group ID
- Logical ID
- Site ID
- Call Type
- Callee ID (Individual Call)
- Use Default Parameters
  - uses parameter values shown in the Edit Parameter screen
- Abort
  - returns you to the screen where you choose trunked or conventional

### Conventional Channels

- Begin Testing
  - using entries shown on the System Information Screen, goes directly to the first test in the procedure.
- Conventional Channel
  - corresponding RX and TX frequencies are displayed
- RX Squelch Type
- TX Squelch Type
- Use Default Parameters
  - uses parameter values shown in the Edit Parameter screen
- Abort
  - returns you to the screen where you choose trunked or conventional

To use the System Information Screen, set parameter *AA use GN value from [0=sys info 1=parm]* to **0=sys info**. If you choose not to use the System Information Screen, set this parameter to **1=parm**







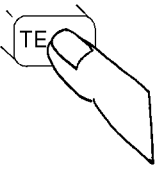

## **Saving a Test Procedure (Procedure Manager)**

A Test Procedure is a collection of pass/fail limits (specifications), the test environment and conditions (parameters), and a TEST sequence, saved in a file that customizes the test software to a specific application. You may save the file to an SRAM memory card or disk.

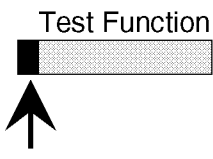
When you save a Procedure you will be saving parameters, specifications, and a test sequence, plus a library that contains the names of all parameters, specifications, and tests that are resident in the HP 11807A,E Software. The library file comes from the HP 11807A,E Software and cannot be modified. The library file will be automatically saved on the card or disk that is being used to store the new test procedure.

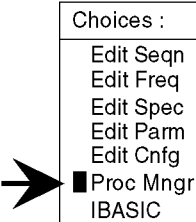

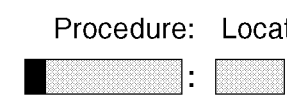

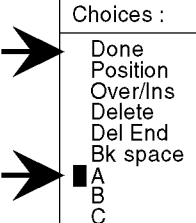
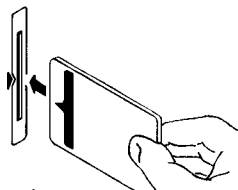

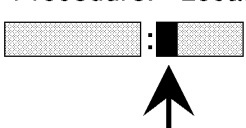

The following example shows how to save a new procedure to a memory card. For more information concerning procedures, see "[Procedures](#)" on page 269 in [chapter 8](#).

## How to Save a Test Procedure

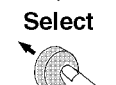
<p><b>1</b> Press <b>TESTS</b> to display the <b>TESTS</b> screen.</p>	<p><b>2</b> Position cursor at <b>Test Function</b> and select it.</p>
<p>If you are in <b>IBASIC</b>, press <b>SHIFT, CANCEL</b> before pressing <b>TESTS</b>.</p> 	<p><b>Position</b></p>  <p><b>Select</b></p>  
<p><b>3</b> Position cursor at <b>Proc Mngr</b> and select it.</p>	<p><b>4</b> Position cursor at <b>Procedure</b> field and select it.</p>
<p><b>Position</b></p>  <p><b>Select</b></p>  	<p><b>Position</b></p>  <p><b>Select</b></p>  
<p><b>5</b> Select characters to name the <b>Procedure</b>, then select <b>Done</b>.</p>	<p><b>6</b> Insert an initialized <b>SRAM</b> memory card.</p>
<p><b>Position</b></p>  <p><b>Select</b></p>  	 <p>(For detailed memory card initialization instructions see Chapter 8 -Memory Cards.)</p>

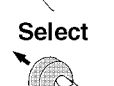
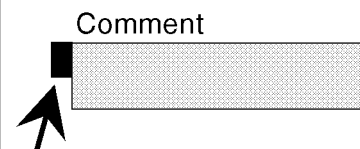
PROCMAN1

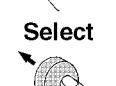

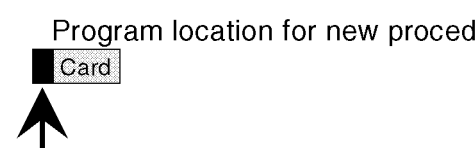
Continue on next page

<p><b>7</b> Position cursor at <b>Location</b> and select it.</p> <p>Procedure: Location</p> 	<p><b>8</b> Position cursor at <b>Card</b> and select it.</p> <p><b>Position</b></p>  <p><b>Select</b></p>  <p>Choices :</p> <ul style="list-style-type: none"> <li><input checked="" type="checkbox"/> Card</li> <li>RAM</li> <li>Disk</li> </ul> <p><i>(You can also save procedures to an internal RAM disk or external disk drive. See Chapter 5-Disks.)</i></p>
<p><b>9</b> Position cursor at <b>Comment</b> and select it. (Optional)</p> <p><b>Position</b></p>  <p><b>Select</b></p>  <p>Comment</p> 	<p><b>10</b> Select characters for the <b>Comment</b>, then select <b>Done</b>.</p> <p><b>Position</b></p>  <p><b>Select</b></p>  <p>Choices :</p> <ul style="list-style-type: none"> <li>Done</li> <li>Position</li> <li>Over/Ins</li> <li>Delete</li> <li>Del End</li> <li>Bk space</li> <li><input checked="" type="checkbox"/> A</li> <li>B</li> <li>C</li> </ul>
<p><b>11</b> Position cursor at <b>Library for new p....</b>, and select <b>Current</b>.</p> <p><b>Position</b></p>  <p><b>Select</b></p>  <p>Library for new procedure</p> <p><u>Current</u> / [NO LIB]</p> <p><i>(The underline indicates which option is selected. Pressing knob changes the selection.)</i></p>	<p><b>12</b> Position cursor at <b>Program location for .....</b> and select it.</p> <p>Program location for new procedure</p> <p>Card</p> 



PROCMA12

Continue on next page

**13** Position cursor at **Card** and select it.

<b>Position</b> 		Choices : ■ Card RAM Disk
<b>Select</b> 		

**14** Position cursor at **Action** and select **Make Procedure**.

<b>Position</b> 	<b>Action</b> ■ Make Procedure Delete Procedure
<b>Select</b> 	<i>(To make selection, position the cursor in front of <b>Make Procedure</b>, then press the knob.)</i>

**15** Press **TESTS** to return to the **TESTS** screen.

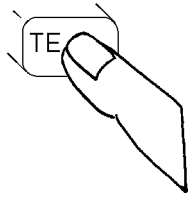

**To run the saved procedure;**

- 1) Load the **Procedure**
- 2) Insert the original HP 11807A memory card
- 3) Press **Run Test**.

*The original card contains the full program needed to allow your procedure to run.*

PROCMA8

## Changing Test Execution Conditions

**Test Execution Conditions** define where and when test output occurs. You may decide to:

- Start the program automatically when the Test Set is powered on. (**Autostart**)
- Stop testing when a measurement fails or continue through all of the tests without stopping. (**On UUT Failure**)
- Display (or print) only measurements that fail, or display (or print) all measurements that pass or fail. (**Output Results**)
- Pause between each measurement, or run through entire test. (**Run Mode**)
- Display output on CRT only, or display on CRT and print hardcopy. (**Output Destination**)

---

**NOTE:**

If printing test results is desired, after selecting **Printer** additional steps are necessary to connect and configure the printer. See "**Printing**" on page 257 in **chapter 8**.

- Enter a title for an output heading for the displayed or printed results. (**Output Heading**)

**Test Execution Conditions** is located on the TESTS screen. Press TESTS to display them. To change a default setting, position the cursor to the desired field. Pressing the knob ("selecting") will toggle the underlined selection.

**Test Execution Conditions** settings are not retained after a power-down/power-up cycle, and will return to their default settings.



## How to Change Test Execution Conditions

The screenshot shows the TESTS menu with the following options and their effects:

- Procedure:** Location Library: Card
- Autostart:** Off/On (Effect: Selecting Autostart On causes testing to begin after power up.)
- On UUT Failure:** Continue/Stop (Effect: Selecting Stop causes the Test Procedure to stop when a failure occurs)
- Run Mode:** Continuous/Single Step (Effect: Selecting Single Step causes the Test Procedure to stop at the end of each measurement)
- Output Results:** All/Failures (Effect: Selecting Failures causes the CRT and printer to display only the measurements that fail)
- Output Destination:** Crt/Printer (Effect: Selecting Printer causes the test procedure results to be output to the CRT and a printer)

Other menu options include: Run Test, Continue, Edit Sean, Edit Freq, Edit Spec, To Screen (RF GEN, RF ANL, AF ANL, SCOPE, SPEC ANL, ENCODER, DECODER, RADIO INT), and More.

TESTEXE1

Chapter 6  
 Using the Software with FW  
 Rev. Below A.14.00

## Printing and Saving Test Results

Printing and saving test results are features of the HP 11807A,E software which require additional equipment and configuration. See **"Printing" on page 257** in **chapter 8** for detailed descriptions and instructions for these features.



---

## Test, Parameter, and Pass/Fail Limit (Specification) Descriptions

Tests are a series of measurements, and one or more tests make up a procedure (see [chapter 5, "Using the Software/HP 8920B, or HP 8920A FW Above Rev. A.14.00"](#)). While you may change the tests that make up a procedure, you may not change the measurements the test will perform. Generally, the order in which the tests are run is not important.

This chapter describes each test and the associated parameters, pass/fail limits, and external equipment that are required. When you first load a test procedure or create a new test sequence, refer to this section to understand what parameters and pass/fail limits are required for each test.

The tests are derived from the following industry standards:

- EIA/TIA-204-D (RX)
- EIA-152-C (TX)
- EIA RS-220 (CTCSS)
- TIA/EIA-603 (RX, TX, Subaudible signaling)

## Factory-Defined Procedures and Defaults

Your HP 11807A,E software memory card comes with a total of six procedures already stored on it; three wideband and three narrowband. The wideband and narrowband procedures have identical test sequences, with some differences in the parameter default settings. Default parameters and pass/fail limits for the procedures are listed with the individual tests and in the [Parameters](#) and [Pass/Fail Limits \(Specifications\)](#) Description sections. Although many of the default parameters and pass/fail limits may be correct for your radio, you should review and edit them before testing; especially the General (GN) parameters. The default channel frequencies will *almost always be different* from your radio's programmed channels (since there are several hundred possible channels).

Parameters and pass/fail limits for each test in these procedures are listed in [chapter 7, "Test, Parameter, and Pass/Fail Limit \(Specification\) Descriptions"](#).

The six factory-defined procedures are:

### **MANUAL (wideband), NB\_MANL (narrowband)**

These procedures perform a single test, test 22 - **RT manual test**, which is described later in this chapter. This test allows you to make several continuous receiver and transmitter measurements, providing a quick functional test of one or more radios.

### **FULL (wideband), NB\_FULL (narrowband)**

These procedures contain all of the tests performed in **TEST\_20: RX quick test** and **TEST\_21: TX quick test**. The tests are performed on *one* channel. You enter the channel number when the System Information Screen is displayed at the start of the tests (channel frequencies are entered in the Channel Information (Edit Frequencies) screen). These procedures provide a detailed test that is especially useful for recently-repaired or newly-programmed radios.

### **CHANS (wideband), NB\_CHAN (narrowband)**

These procedures perform tests 2 through 18 on *all* test channels indicated on the Channel Information (Edit Frequencies) screen, regardless of what channel you enter on the System Information Screen at the start of the procedure. These procedures provide overall functional tests and channel programming verification.

## Shared Parameters

Many parameters are used in more than one test. For example, all transmitter tests use parameter *TX user/system key UUT* to determine how the transmitter is keyed during tests.

Once you have entered the correct parameter value, the same value should work with all tests that use that parameter.

## Prefixes and Abbreviations: GN, RT, RX, TX, Trunked, Conv

All tests, parameters, and pass/fail limits are prefixed by a two-letter code representing when they are used. For example, the parameter *RX audio load impedance* is used for receiver tests.

- **GN:** General - used to identify a group of parameters that are associated with signaling information or the given system selected on the radio.
- **RT:** Receiver/Transmitter - used to identify parameters that may be used for both receiver and transmitter tests, and tests which make both receiver and transmitter measurements.
- **RX:** Receiver - used to identify tests, parameters, and pass/fail limits used only for receiver tests.
- **TX:** Transmitter - used to identify tests, parameters, and pass/fail limits used only for transmitter tests.

### Trunked/Conventional Channel References

Many tests, parameters, and pass/fail limits are unique to trunked channel testing, and are identified by the term *trunked*. Example, parameter *RT trunked signaling high speed deviation*.

Other tests, parameters, and pass/fail limits are unique to conventional channel testing, and are identified by the term *conv*. Example, parameter *RX conv squelch blocking*.

If the name of a test, parameter, or pass/fail limit does not contain *trunked* or *conv*, it is used for *both* trunked and conventional channel tests.

## General (GN) Parameters

Before any radio tests are performed, you must indicate what channel you want to test, and enter your radio's pre-programmed information (site ID, control channel, working channel, group ID, squelch type, squelch code, and so forth). This information can be provided using either of two methods:

- Entering the information on the System Information screen at the start of each test.
- Entering the information in parameters with the GN prefix.

Parameter *AA use GN value from [0=sys info 1=parm]* allows you to set which method to use.

### Using the System Information Screen

If parameter *AA use GN value from [0=sys info 1=parm]* is set to **0=sys**, you are prompted to select the type of radio to test (trunked or conventional) and to enter information on the System Information screen each time you begin testing.

Use the System Information Screen if:

- you are testing different systems on the same radio with the same test sequence, for example, trunked and conventional channels.
- you are testing several radios that are pre-programmed with different information, but share the same channel assignments.

### Using General Parameters

If parameter *AA use GN value from [0=sys info 1=parm]* is set to **1**, the System Information screen is not displayed and you are not prompted to choose the radio type. The software now gets the radio information from the GN parameters, and testing begins almost immediately after you press **Run Test**.

Use the General Parameters if:

- You are repeatedly running the same test(s) on a radio, or when running the same test on several radios that were pre-programmed with the same information.

## Testing Multiple Channels

Multiple channel testing is initiated by using either of the following methods:

- To use the System Information Screen, set parameter *AA use GN value from [0=sys info 1=parm]* to **0=sys info**.
  - For a trunked system: set the working channel number = 0
  - For a conventional system: set the conventional channel number = 0
- To use the Parameter table, set parameter *AA use GN value from [0=sys info 1=parm]* to **1=parm**.
  - For a trunked system: set parameter *GN choose radio type [0=conv 1=trunked]* to **1=trunked**. Then set parameter *GN trunked working chan # [0 or 1-25; 0=all ch]* to **0=all ch**.
  - For a conventional system: set parameter *GN choose radio type [0=conv 1=trunked]* to **0=conv**. Then set parameter *GN conv chan # [0=all chans or 26-50]* to **0=all chans**.

---

**NOTE:** Once a multiple channel sequence is started, all selected conventional and trunked channels will be tested.

---



---

## Test\_01: TX and RX stand-by current drain

This test measures the radio's power supply current under two conditions:

- with the un-modulated transmitter keyed, and
- with the transmitter de-keyed and the receiver's audio squelched.

If a programmable power supply is configured in the External Devices (Edit Configuration) screen, the current measurement is supplied over HP-IB by the power supply. Refer to chapter 2 - *Making Connections*.

If a programmable power supply is not used, current is measured using the optional DC Current Measurement function of the HP 8920A Option 003.

---

### MEASUREMENT CALIBRATION

This software does not calibrate the current measurement function of the HP 8920A. Manual calibration should be done the first time current is measured, and any time negative current has been applied by reversing current measurement connections. Refer to the *DC CURRENT MEASUREMENT* information in chapter 4 of the *HP 8920A User's Guide*.

To calibrate the DC Current Measurement:

1. Disconnect any connections to the HP 8920A,D's rear-panel DC CURRENT MEASUREMENT connectors.
2. Access the AF ANALYZER screen.
3. Select the **DC Current** field to zero the measurement.

### Parameters Used

#### Conventional Radios Only

- **RX conv squelch control [0=no 1=yes]:** Default value =0
- **RX conv squelch preset only [0=no 1=yes]:**  
Default value = 0 [0=no 1=yes]
- **TX conv CT/CDCSS control [0=no, 1=yes]:** Default value = 0

### Trunked Radios Only

- **RT external RF pad and cable loss (dB):** Default value = 0
- **RT trunked invert [0=no 1=rx 2=tx 3=both]:** Default value = 0
- **RT trunked signaling deviation, high speed (kHz)** Default value = 3
- **RT trunked signaling deviation, subaudible (kHz)** Default value = 0.75

### Conventional and Trunked Radios

- **RT nominal supply voltage (Vdc):** Default value = 13.8
- **RT standard RF input level (mV)** Default value = 20
- **TX de-key between TX tests [0=no 1=yes]:** Default value = 1
- **TX user/system key UUT [0=user 1=sys]:** Default value = 0

Also set all appropriate GN parameters (see "**General (GN) Parameters**" on page 151)

### Pass/fail limits Used

- **18. RX stand-by current drain (Amps):**  
Default values: LL=none UL=.5
- **29. TX current drain (Amps):**  
Default values: LL=none UL=7.5

### External Equipment

- This test requires HP 8920A option 003: HP-IB/Serial Communications/Current Measurement.
- This test requires an HP-IB programmable power supply (current measurement capability is optional).

---

## Test\_02: TX frequency error

This test compares the radio's measured transmitter frequency to the transmit frequency entered in the Channel Information (Edit Frequencies) screen.

### Parameters Used

#### Conventional Radios Only

- **TX conv CT/CDCSS control [0=no, 1=yes]:** Default value = 0

#### Trunked Radios Only

- **RT external RF pad and cable loss (dB):** Default value = 0
- **RT trunked invert [0=no 1=rx 2=tx 3=both]:** Default value = 0
- **RT trunked signaling deviation, high speed (kHz)** Default value = 3
- **RT trunked signaling deviation, subaudible (kHz)** Default value = .75

#### Conventional and Trunked Radios

- **RT nominal supply voltage (Vdc):** Default value = 13.8
- **RT standard RF input level (mV)** Default value = 20
- **TX de-key between TX tests [0=no 1=yes]:** Default value = 1
- **TX user/system key UUT [0=user 1=sys]:** Default value = 0

Also set all appropriate GN parameters (see "**General (GN) Parameters**" on page 151)

### Pass/fail limits Used

- **29. TX current drain (Amps):** Default values: LL=none UL=7.5
- **32. TX frequency error (ppm):** Default values: LL=-2.5 UL=2.5

---

## Test\_03: TX output power

This test measures the transmitter's output power at the nominal power supply voltage. If a programmable power supply is used, power is also measured at high and low supply voltages.

If your radio has a high/low transmitter power switch, both power levels are measured when parameter *TX power high/low switch* [0=no 1=yes] is set to **1=yes**.

### Parameters Used

#### Conventional Radios Only

- **TX conv CT/CDCSS control** [0=no, 1=yes]: Default value = 0

#### Trunked Radios Only

- **RT trunked invert** [0=no 1=rx 2=tx 3=both]: Default value = 0
- **RT trunked signaling deviation, high speed (kHz)**  
Default value = 3
- **RT trunked signaling deviation, subaudible (kHz)**  
Default value = .75

### Conventional and Trunked Radios

- **RT external RF pad and cable loss (dB):** Default value = 0
- **RT high supply voltage (Vdc):** Default value = 16.8
- **RT low supply voltage (Vdc):** Default value = 10.8
- **RT nominal supply voltage (Vdc):** Default value = 13.8
- **RT standard RF input level (mV)** Default value = 20
- **TX de-key between TX tests [0=no 1=yes]:** Default value = 1
- **TX power high/low switch [0=no 1=yes]:** Default value = 0
- **TX user/system key UUT [0=user 1=sys]:** Default value = 0

Also set all appropriate GN parameters (see "**General (GN) Parameters**" on page 151).

### Pass/fail limits Used

- **29. TX current drain (Amps):** Default values: LL=none UL=7.5
- **35. TX output power (Watts):** Default values: LL=10 UL=17
- **36. TX output power at high supply (Watts):** Default values: LL=10 UL=17
- **37. TX output power at high supply low switch (Watts):** Default values: LL=5 UL=10
- **38. TX output power at low supply (Watts):** Default values: LL=10 UL=17
- **39. TX output power at low supply low switch (Watts):** Default values: LL=5 UL=10
- **40. TX output power low switch setting (Watts):** Default values: LL=5 UL=10

### External Equipment

- HP-IB programmable power supply when making high and low supply power measurements (optional).

---

## Test\_04: TX modulation limiting

*This test is not performed on trunked voice guard call types.*

This test verifies your radio's ability to limit transmitter modulation when a modulating signal in excess of the rated system deviation is input.

This test first measures the instantaneous frequency deviation of the transmitter with an applied 1 kHz modulating signal that is 20 dB higher than the level needed for 60% of rated maximum deviation. Both the positive and negative peaks are measured.

If the frequency sweep step size (parameter *TX modulation limiting sweep step freq*) is >0, the modulating frequency is then swept from 300 Hz to 3 kHz, measuring the deviation at each step. If this parameter is set to 0, the modulating frequency stays at 1 kHz.

### Analyzer Settings

- **Pk+ Hold** and **Pk- Hold** detectors are used for the instantaneous measurements.
- **Pk+** and **Pk-** detectors are used for the steady-state swept measurements.
- De-emphasis 750  $\mu$ s.
- Filter 1: <20 Hz HPF
- Filter 2: 15 kHz LPF

### Parameters Used

#### Conventional Radios Only

- **TX conv CT/CDCSS control [0=no, 1=yes]:** Default value = 0

#### Trunked Radios Only

- **RT external RF pad and cable loss (dB):** Default value = 0
- **RT trunked invert [0=no 1=rx 2=tx 3=both]:** Default value = 0
- **RT trunked signaling deviation, high speed (kHz)** Default value= 3
- **RT trunked signaling deviation, subaudible (kHz)** Default value=.75

### Conventional and Trunked Radios

- **RT full rated system deviation (kHz):** Default value = 4.5
- **RT nominal supply voltage (Vdc):** Default value = 13.8
- **RT signaling filter 1 opt [0=no 1=yes]** Default value = 1
- **RT standard RF input level (mV)** Default value = 20
- **TX de-key between TX tests [0=no 1=yes]:** Default value = 1
- **TX modulation limiting sweep step freq (kHz):** Default value = 2.7
- **TX user/system key UUT [0=user 1=sys]:** Default value = 0

Also set all appropriate GN parameters (see "**General (GN) Parameters**" on page 151).

### Pass/fail limits Used

- **29. TX current drain (Amps):** Default values: LL=none UL=7.5
- **33. TX microphone sensitivity (mVrms):** Default values: LL=100 UL=150
- **34. TX modulation limiting (kHz):** Default values: LL=none UL=5

## Test\_05: TX audio frequency response

*This test is not performed on trunked voice guard call types.*

This test compares the audio frequency response of your transmitter to a 6 dB/octave pre-emphasis curve from 0.5 kHz to 2.5 kHz (pass/fail limit *TX audio response delta from 6 dB/oct*). Variation from that pre-emphasis curve is measured separately for frequencies <0.5 kHz and >2.5 kHz (pass/fail limit *TX audio freq response roll <.5 kHz* and pass/fail limit *TX audio response roll >2.5 kHz*).

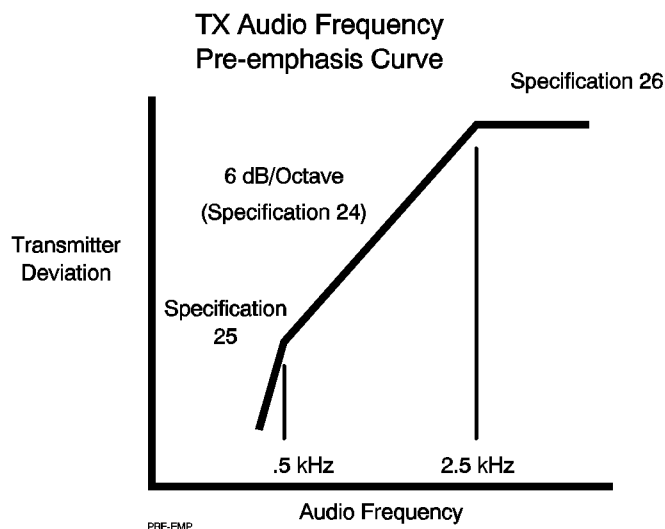

During the test, the transmitter is set to 20% of maximum rated deviation at a 1 kHz rate, and an audio level reference is taken. The modulating frequency is then stepped from 300 Hz to 3 kHz, and the response is compared to the pass/fail limits. The number of steps is determined by parameter *RX audio freq response step frequency*. The displayed error for each frequency step is the difference between the measured value and the computed pre-emphasis curve.



## Analyzer Settings

- RMS Detector
- De-emphasis off.
- Filter 1:
  - If a conventional radio is tested without CT or CDCSS signaling, or if parameter *TX conv CT/CDCSS control* is set to **1=yes** to control signaling, a 50 Hz HPF is used.
  - If a trunked radio is tested, or a conventional radio using CT or CDCSS signaling, a 300 Hz HPF is the default audio filter.
- Filter 2: 15 kHz LPF

## Parameters Used

### Conventional Radios Only

- **TX conv CT/CDCSS control [0=no, 1=yes]:** Default value = 0

### Trunked Radios Only

- **RT external RF pad and cable loss (dB):** Default value = 0
- **RT trunked invert [0=no 1=rx 2=tx 3=both]:**  
Default value = 0
- **RT trunked signaling deviation, high speed (kHz)**  
Default value = 3
- **RT trunked signaling deviation, subaudible (kHz)**  
Default value = .75

### Conventional and Trunked Radios

- **RT full rated system deviation (kHz):** Default value = 4.5
- **RT nominal supply voltage (Vdc):** Default value = 13.8
- **RT signaling filter 1 opt [0=no 1=yes]** Default value = 1
- **RT standard RF input level (mV)** Default value = 20
- **TX audio freq response start frequency (kHz):**  
Default value = 0.3
- **TX audio freq response step frequency (kHz):**  
Default value = 0.5
- **TX audio frequency response stop frequency (kHz):**  
Default value = 3
- **TX de-key between TX tests [0=no 1=yes]:** Default value = 1
- **TX user/system key UUT [0=user 1=sys]:** Default value = 0

Also set all appropriate GN parameters (see "**General (GN) Parameters**" on page 151).

### Pass/fail limits Used

- **24. TX audio response delta from 6 dB/oct (dB):**  
Default values: LL=-3 UL=1
- **25. TX audio freq response roll <.5 kHz (dB/oct):**  
Default values: LL=none UL=6
- **26. TX audio response roll >2.5 kHz (dB/oct):**  
Default values: LL=none UL=6
- **29. TX current drain (Amps):** Default values: LL=none UL=7.5
- **33. TX microphone sensitivity (mVrms):**  
Default values: LL=100 UL=150

---

## Test\_06: TX audio distortion

*This test is not performed on trunked voice guard call types.*

This test measures the audio frequency harmonic distortion induced by the audio and RF circuits of a transmitter. Distortion is measured at a 1 kHz rate, with the deviation determined by parameter *RT full rated system deviation* and parameter *TX audio distn % full rated system deviation*.

### Analyzer Settings

- Filter 1: The 300 Hz HPF is always used unless the optional 400 Hz HPF is installed (HP 8920A option 010). If Option 010 is installed and selected by parameter *RT signaling filter 1 opt* being set to 1 = yes, the 400 Hz HPF is used when testing a trunked transmitter or conventional transmitter using CTCSS or CDCSS signaling.
- Filter 2: 3 kHz LPF
- De-Emphasis: 750  $\mu$ s

### Parameters Used

#### Conventional Radios Only

- **TX conv CT/CDCSS control [0=no, 1=yes]:** Default value = 0

#### Trunked Radios Only

- **RT external RF pad and cable loss (dB):** Default value = 0
- **RT trunked invert [0=no 1=rx 2=tx 3=both]:** Default value = 0
- **RT trunked signaling deviation, high speed (kHz) Default value= 3**
- **RT trunked signaling deviation, subaudible (kHz)**  
Default value=.75

### Conventional and Trunked Radios

- **RT full rated system deviation (kHz):** Default value = 4.5
- **RT nominal supply voltage (Vdc):** Default value = 13.8
- **RT signaling filter 1 opt [0=no 1=yes]** Default value = 1
- **RT standard RF input level (mV)** Default value = 20
- **TX audio distn % full rated system dev (%):**  
Default value = 60
- **TX de-key between TX tests [0=no 1=yes]:** Default value = 1
- **TX user/system key UUT [0=user 1=sys]:** Default value = 0

Also set all appropriate GN parameters (see "**General (GN) Parameters**" on page 151)

### Pass/fail limits Used

- **23. TX audio distortion (%):** Default values: LL=none UL=10
- **29. TX current drain (Amps):** Default values: LL=none UL=7.5
- **33. TX microphone sensitivity (mVrms):**  
Default values: LL=100 UL=150

---

## Test\_07: TX microphone sensitivity

*This test is not performed on trunked voice guard call types.*

This test measures the microphone audio input level needed to produce the specified amount of transmitter deviation. The measurement is made using either of two methods:

- If parameter *TX mic sens set and measure* is set to **0=no**, the audio level input to the microphone is varied until 60% deviation is measured. The audio level is then compared to the limits for pass/fail limit *TX microphone sensitivity*.
- If parameter *TX mic sens set and measure* is set to **1=yes**, the audio level input to the microphone is set half-way between the lower and upper limits of pass/fail limit *TX microphone sensitivity*. The resulting deviation is then compared to the limits for pass/fail limit *TX deviation if set and measure mic sens*. *This is the fastest method for this measurement.*

### Analyzer Settings

- Filter 1: The 300 Hz HPF is always used unless the optional 400 Hz HPF is installed (HP 8920A option 010). If Option 010 is installed and selected by parameter *RT signaling filter 1 opt* being set to 1 = yes, the 400 Hz HPF is used when testing a trunked transmitter or conventional transmitter using CTCSS or CDCSS signal.
- Filter 2: 3 kHz LPF
- De-emphasis: 750  $\mu$ s
- Detector: Pk+

### Parameters Used

#### Conventional Radios Only

- **TX conv CT/CDCSS control [0=no, 1=yes]:** Default value = 0

#### Trunked Radios Only

- **RT external RF pad and cable loss (dB):** Default value = 0
- **RT trunked invert [0=no 1=rx 2=tx 3=both]:** Default value = 0
- **RT trunked signaling deviation, high speed (kHz)**  
Default value= 3
- **RT trunked signaling deviation, subaudible (kHz)**  
Default value=.75

### Conventional and Trunked Radios

- **RT full rated system deviation (kHz): Default value = 4.5**
- **RT signaling filter 1 opt [0=no 1=yes]** Default value = 1
- **RT standard RF input level (mV)** Default value = 20
- **TX de-key between TX tests [0=no 1=yes]:** Default value = 1
- **TX mic sens set and measure [0=no 1=yes]** Default value = 0
- **TX user/system key UUT [0=user 1=sys]:** Default value = 0

Also set all appropriate GN parameters (see "**General (GN) Parameters**" on page 151).

### Pass/fail limits Used

- **29. TX current drain (Amps):** Default values: LL=none UL=7.5
- **30. TX deviation if set and measure mic sens (kHz):**  
Default values: LL=2.5 UL=3.5
- **33. TX microphone sensitivity (mVrms):**  
Default values: LL=100 UL=150

---

## Test\_08: TX FM hum and noise

*This test is not performed on trunked voice guard call types.*

This test compares the transmitter's residual frequency modulation (deviation with no modulating signal applied) to a reference of 60% full rated deviation at a 1 kHz rate. The result is displayed as a ratio (dB), and is calculated using the formula:

$$20 \times \text{Log} \frac{\text{ReferenceDeviation}}{\text{ResidualDeviation}} = \text{dB}$$

For example, if the full rated deviation is 5 kHz, 60% = 3 kHz. If the transmitter has a measured deviation of 150 Hz with no signal applied, the resulting test result is:

$$20 \times \text{Log} \frac{3000}{150} = 26 \text{dB}$$

### Analyzer Settings

- Filter 1: If a trunked radio is tested, or a conventional radio using CT or CDCSS signaling, a 300 Hz HPF is the default audio filter. If installed, the optional 400 Hz HPF signaling filter is used if parameter *RT signaling filter 1 opt* [0=no 1=yes] is set to **1=yes**.
- Filter 2: 3 kHz LPF
- De-emphasis: 750 μs
- Detector: RMS

## Parameters Used

### Conventional Radios Only

- **TX conv CT/CDCSS control [0=no, 1=yes]:** Default value = 0

### Trunked Radios Only

- **RT external RF pad and cable loss (dB):** Default value = 0
- **RT trunked invert [0=no 1=rx 2=tx 3=both]:**  
Default value = 0
- **RT trunked signaling deviation, subaudible (kHz)**  
Default value= 3
- **RT trunked signaling deviation, subaudible (kHz)**  
Default value=.75

### Conventional and Trunked Radios

- **RT full rated system deviation (kHz):** Default value = 4.5
- **RT signaling filter 1 opt [0=no 1=yes]** Default value = 1
- **RT standard RF input level (mV)** Default value = 20
- **TX de-key between TX tests [0=no 1=yes]:** Default value = 1
- **TX user/system key UUT [0=user 1=sys]:** Default value = 0

Also set all appropriate GN parameters (see "**General (GN) Parameters**" on page 151).

## Pass/fail limits Used

- **29. TX current drain (Amps):** Default values: LL=none UL=7.5
- **31. TX FM hum and noise (dB):** Default values: LL=30 UL=none
- **33. TX microphone sensitivity (mVrms):**  
Default values: LL=100 UL=150



---

## Test\_09: TX residual AM hum and noise

*This test is not performed on trunked voice guard call types.*

This test measures the level (in percent) of transmitter amplitude modulation present with no modulating signal applied.

### Analyzer Settings

- Filter 1: If a trunked radio, or a conventional radio using CT or CDCSS signaling is tested, a 300 Hz HPF is the default audio filter. If installed, the optional 400 Hz HPF signaling filter is used if parameter *RT signaling filter 1 opt* [0=no 1=yes] is set to **1=yes**.
- Filter 2: 3 kHz LPF
- De-emphasis: 750  $\mu$ s
- Detector: Pk+

### Parameters Used

#### Conventional Radios Only

- **TX conv CT/CDCSS control** [0=no, 1=yes]: Default value = 0

#### Trunked Radios Only

- **RT external RF pad and cable loss (dB)**: Default value = 0
- **RT trunked invert** [0=no 1=rx 2=tx 3=both]:  
Default value = 0
- **RT trunked signaling deviation, high speed (kHz)**  
Default value = 3
- **RT trunked signaling deviation, subaudible (kHz)**  
Default value = .75

### Conventional and Trunked Radios

- **RT signaling filter 1 opt [0=no 1=yes]** Default value = 1
- **RT standard RF input level (mV)** Default value = 20
- **TX de-key between TX tests [0=no 1=yes]:** Default value = 1
- **TX user/system key UUT [0=user 1=sys]:** Default value = 0

Also set all appropriate GN parameters (see "**General (GN) Parameters**" on page 151).

### Pass/fail limits Used

- **29. TX current drain (Amps):** Default values: LL=none UL=7.5
- **41. TX residual AM hum and noise (%AM):**  
Default values: LL=none UL=2

---

## Test\_10: TX signaling deviation & freq/code

This test measures signaling data and deviation for trunked, CTCSS, and CDCSS signaling. This test is not used for Carrier Squelch (CS) radios.

*Trunked Radios* - For Group, Emergency, and Individual Call Types, the transmitted data message is displayed, and the transmitted trunking low speed data's peak+ and peak- deviation are measured. For a Voice Guard Call Type, the transmitted data message is displayed, and the transmitted voice guard high speed data's peak+ and peak- deviation are measured.

*Conventional CTCSS Radios* - The transmitted squelch tone's peak deviation and frequency error are measured and displayed.

*Conventional CDCSS Radios* - The transmitted squelch code's peak+ and peak- deviation are measured, and the squelch code is displayed. The CTCSS frequency and CDCSS code are compared to the values entered in any of three different places:

1. The System Information Screen that appears at the start of testing (if parameter *AA use GN value from [0=sys info 1=parm]* is set to **0=sys info**).
2. The General Parameters (if parameter *AA use GN value from [0=sys info 1=parm]* is set to **1=parm**).
3. The **TX Chan Info** field for the channel you are testing. A value in this field overrides the General Parameters. Refer to the "**Channel Information (Frequencies)**" on page 223 in chapter 8 to see how to do this.

Trunked data is compared to the information you enter in either the System Information Screen or in the General Parameters (depending on the setting for parameter *AA use GN value from [0=sys info 1=parm]*).

### Analyzer Settings

- Filter 1: <20 Hz HPF
- Filter 2: 15 kHz LPF
- De-emphasis: 750  $\mu$ s

## Parameters Used

### Conventional Radios Only

- **RX conv CT/CDCSS deviation (kHz):** Default value = 0.75
- **TX conv CT/CDCSS control [0=no, 1=yes]:** Default value = 0

### Trunked Radios Only

- **RT external RF pad and cable loss (dB):** Default value = 0
- **RT trunked invert [0=no 1=rx 2=tx 3=both]:**  
Default value = 0
- **RT trunked signaling deviation, high speed (kHz)**  
Default value= 3
- **RT trunked signaling deviation, subaudible (kHz)**  
Default value=.75

### Trunked and Conventional Radios

- **RT standard RF input level (mV)** Default value = 20
- **TX de-key between TX tests [0=no 1=yes]:** Default value = 1
- **TX user/system key UUT [0=user 1=sys]:** Default value = 0

Also set all appropriate GN parameters (see "**General (GN) Parameters**" on page 151).

## Pass/fail limits Used

- **27. TX conv CT/CDCSS deviation (kHz):** Default values: LL=.5 UL=1
- **28. TX conv CTCSS frequency error (%):** Default values: LL=-5 UL=5
- **29. TX current drain (Amps):** Default values: LL=none UL=7.5
- **42. TX trunked deviation, low speed (kHz):** Default values: LL=.5 UL=1
- **43. TX trunked deviation, high speed (kHz):**  
Default values: L=2.0 UL=4.0

---

## Test\_11: RX hum and noise

*This test is not performed on trunked voice guard call types.*

This test compares the receiver audio level with and without a modulated carrier applied. If CTCSS or CDCSS signaling is used, the squelched measurement is made a second time with signaling on. Both squelched and unsquelched measurements can be made; however, the *squelched measurement cannot be made on trunked radios.*

*The Unsquelched Measurement* The RF carrier is set to the standard RF level at 60% of rated deviation at a 1 kHz rate. The audio level is set to the maximum rated power and measured. The modulation is then turned off, and the audio level is measured again. The displayed measurement is the ratio of the audio levels with and without the carrier being modulated. The method used for CDCSS and CTCSS radios is the same, but is performed with signaling turned on.

*The Squelched Measurement* The RF carrier is set to the standard RF level at 60% of rated deviation at a 1 kHz rate. The audio level is set to the maximum rated power and measured. The RF carrier is then removed. If the radio has a squelch control, squelch is set tight (maximum). If squelch control is not used, it is assumed the radio will squelch the audio when a carrier is not present. The audio level is then measured again. The displayed measurement is the ratio of the audio level with and without a modulated carrier present.

### Analyzer Settings

- Filter 1: 300 Hz HPF
- Filter 2: 3 kHz LPF
- De-emphasis: off
- Detector: RMS

## Parameters Used

### Conventional Radios Only

- **RX conv CT/CDCSS deviation (kHz):** Default value = 0.75
- **RX conv squelch control [0=no 1=yes]:** Default value = 0
- **RX conv squelch preset only [0=no 1=yes]:** Default value = 0

### Trunked Radios Only

- **RT trunked invert [0=no 1=rx 2=tx 3=both]:** Default value = 0
- **RT trunked signaling deviation, high speed (kHz)**  
Default value= 3
- **RT trunked signaling deviation, subaudible (kHz)**  
Default value=.75

### Conventional and Trunked Radios

- **RT external RF pad and cable loss (dB):** Default value = 0
- **RT full rated system deviation (kHz):** Default value = 4.5
- **RT standard RF input level (mV)** Default value = 20
- **RX audio load impedance (Ohms):** Default value = 4
- **RX audio maximum power (Watts):** Default value = 1
- **RX set radio volume [0=no 1=yes]:** Default value = 1
- **RX tolerance for setting volume (% error):** Default value = 20

Also set all appropriate GN parameters (see "**General (GN) Parameters**" on page 151).

## Pass/fail limits Used

- **9. RX conv hum and noise squelched (dB):**  
Default values: LL=60 UL=none
- **10. RX conv hum and noise with signaling (dB):**  
Default values: LL=30 UL=none
- **17. RX hum and noise unsquelched (dB):** Default values: LL=30 UL=none
- **29. TX current drain (Amps):** Default values: LL=none UL=7.5

---

## Test\_12: RX audio distortion

*This test is not performed on trunked voice guard call types.*

This test measures the receiver's audio distortion at two volume levels; 17 dB below the maximum audio level, and then at the maximum audio level. Both measurements are made with 1 kHz modulation tone, and at 60% of rated deviation.

### Analyzer Settings

- Filter 1: 300 Hz HPF
- Filter 2: 15 kHz LPF
- De-emphasis: Off
- Detector: RMS

### Parameters Used

#### Conventional Radios Only

- **RX conv CT/CDCSS deviation (kHz):** Default value = 0.75
- **RX conv squelch control [0=no 1=yes]:** Default value = 0
- **RX conv squelch preset only [0=no 1=yes]:**  
Default value = 0 [0=no 1=yes]

#### Trunked Radios Only

- **RT trunked invert [0=no 1=rx 2=tx 3=both]:**  
Default value = 0
- **RT trunked signaling deviation, high speed (kHz)**  
Default value= 3
- **RT trunked signaling deviation, subaudible (kHz)**  
Default value=.75

### Conventional and Trunked Radios

- **RT external RF pad and cable loss (dB):** Default value = 0
- **RT full rated system deviation (kHz):** Default value = 4.5
- **RT standard RF input level (mV)** Default value =20
- **RX audio load impedance (Ohms):** Default value = 4
- **RX audio maximum power (Watts):** Default value = 1
- **RX set radio volume [0=no 1=yes]:** Default value = 1
- **RX tolerance for setting volume (% error):** Default value = 20

Also set all appropriate GN parameters (see "**General (GN) Parameters**" on page 151).

### Pass/fail limits Used

- **1. RX audio distn 17 dB below rated power (%):**  
Default values: LL=none UL=5
- **2. RX audio distortion (%):** Default values: LL=none UL=10
- **29. TX current drain (Amps):** Default values: LL=none UL=7.5



## Test\_13: RX frequency response

*This test is not performed on trunked voice guard call types.*

This test compares the audio frequency response of your transmitter to a true 6 dB/octave de-emphasis curve from 0.5 kHz to 2.5 kHz (pass/fail limit *RX audio freq resp delta from 6 dB/oct*). Frequency response is measured separately for deviation from that de-emphasis curve for frequencies <0.5 kHz and >2.5 kHz (pass/fail limit *RX audio freq response roll < 0.5 kHz* and pass/fail limit *RX audio freq response roll > 2.5 kHz*).

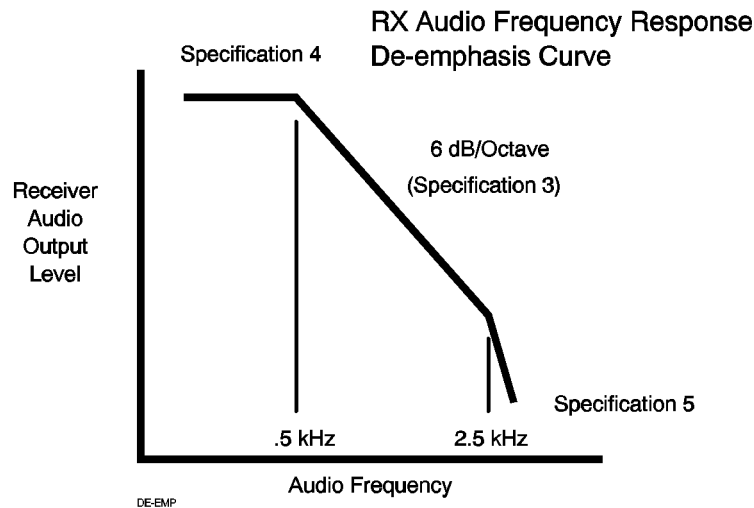

During the test, the HP 8920A,D's AF generator is set to 20% of maximum rated deviation at a 1 kHz rate, and the receiver's volume is adjusted to 50% of maximum rated power. An audio level reference is then taken.

The audio frequency is then stepped from 300 Hz to 3 kHz, and the response is compared to the limits in pass/fail limit *RX audio freq resp delta from 6 dB/oct*. The number of steps is determined by parameter *TX audio freq response step frequency (kHz)*. The displayed error for each frequency step is the difference between the measured value and the computed (ideal) de-emphasis curve.

## Analyzer Settings

- Filter 1: 50 Hz HPF
- Filter 2: 15 kHz LPF
- De-emphasis: Off
- Detector: RMS

## Parameters Used

### Conventional Radios Only

- **RX conv CT/CDCSS deviation (kHz):** Default value = 0.75
- **RX conv squelch control [0=no 1=yes]:** Default value = 0
- **RX conv squelch preset only [0=no 1=yes]:** Default value = 0

### Trunked Radios Only

- **RT trunked invert [0=no 1=rx 2=tx 3=both]:**  
Default value = 0
- **RT trunked signaling deviation, high speed (kHz)**  
Default value = 3
- **RT trunked signaling deviation, subaudible (kHz)**  
Default value = .75

### Conventional and Trunked Radios

- **RT external RF pad and cable loss (dB):** Default value = 0
- **RT full rated system deviation (kHz):** Default value = 4.5
- **RT standard RF input level (mV)** Default value = 20
- **RX audio freq response step frequency (kHz):**  
Default value = 0.5
- **RX audio load impedance (Ohms):** Default value = 4
- **RX audio maximum power (Watts):** Default value = 1
- **RX set radio volume [0=no 1=yes]:** Default value = 1
- **RX tolerance for setting volume (% error):** Default value = 20

Also set all appropriate GN parameters (see "**General (GN) Parameters**" on page 151).

**Pass/fail limits Used**

- **3. RX audio freq resp delta from 6dB/oct (dB):**  
Default values: LL=-8 UL=2
- **4. RX audio freq response roll <.5 kHz (dB/oct):**  
Default values: LL=none UL=6
- **5. RX audio freq response roll>2.5 kHz (dB/oct):**  
Default values: LL=none UL=6
- **29. TX current drain (Amps):** Default values: LL=none UL=7.5

---

## Test\_14: RX usable sensitivity

*This test is not performed on trunked voice guard call types.*

This test measures the receiver's sensitivity at 60% of rated deviation at a 1 kHz rate. Receiver audio level (volume) is a maximum rated power. The measurement is made using either of two methods:

1. The RF generator level is adjusted until the *lower* limit for the pass/fail limit *RX usable sensitivity SINAD level* is reached. The RF generator's output level is then compared to the pass/fail limit *RX usable sensitivity* pass/fail limit.
2. The RF generator is set to the *upper* limit level for the pass/fail limit *RX usable sensitivity*, and the resulting SINAD measurement is compared to the pass/fail limit *RX usable sensitivity SINAD level*. This is the fastest method.

Method 2 is always used for testing trunked radios. The method used for testing conventional radios depends on parameter *RX conv sens set and meas* [0=no 1=yes] (see "[Parameters Descriptions](#)" on page 207).

### Analyzer Settings

- Filter 1: 300 Hz HPF
- Filter 2: 3 kHz LPF
- De-emphasis: Off
- Detector: RMS

### Parameters Used

#### Conventional Radios Only

- **RX conv CT/CDCSS deviation (kHz):** Default value = 0.75
- **RX conv sens set and meas [0=no 1=yes]:** Default value = 1
- **RX conv squelch control [0=no 1=yes]:** Default value = 0
- **RX conv squelch preset only [0=no 1=yes]:** Default value = 0

**Trunked Radios Only**

- **RT trunked invert [0=no 1=rx 2=tx 3=both]:**

Default value = 0

- **RT trunked signaling deviation, high speed (kHz)**

Default value= 3

- **RT trunked signaling deviation, subaudible (kHz)** Default value = .75

**Conventional and Trunked Radios**

- **RT external RF pad and cable loss (dB):** Default value = 0

- **RT full rated system deviation (kHz):** Default value = 4.5

- **RT standard RF input level (mV)** Default value = 20

- **RX audio load impedance (Ohms):** Default value = 4

- **RX audio maximum power (Watts):** Default value = 1

- **RX set radio volume [0=no 1=yes]:** Default value = 1

- **RX tolerance for setting volume (% error):** Default value = 20

Also set all appropriate GN parameters (see "**General (GN) Parameters**" on page 151).

**Pass/fail limits Used**

- **21. RX usable sensitivity (mV):** Default values: LL=none UL=.2
- **22. RX usable sensitivity SINAD level (dB):** Default values: LL=8 UL=none
- **29. TX current drain (Amps):** Default values: LL=none UL=7.5

---

## Test\_15: RX conv audio squelch sensitivity

*This test is not performed on trunked radios.*

This test measures the minimum RF signal level required to open (break) squelch on the receiver, with the carrier set to 60% of rated deviation, and a modulation rate of 1 kHz. SINAD is also measured at squelch opening.

Both the squelch threshold and the maximum (tight) squelch measurements are made on conventional radios with an external variable squelch adjustment.

The tight squelch measurement is not made for radios with only a preset squelch control switch or no squelch control. Parameter *RX conv squelch control* [0=no 1=yes] and parameter *RX conv squelch preset only* [0=no 1=yes] tell the software what type of squelch your conventional radio uses.

### Analyzer Settings

- Filter 1: 300 Hz HPF
- Filter 2: 3 kHz LPF
- De-emphasis: Off
- Detector: RMS

### Parameters Used

#### Conventional Radios Only

- **RT external RF pad and cable loss (dB):** Default value = 0
- **RT full rated system deviation (kHz):** Default value = 4.5
- **RT standard RF input level (mV)** Default value = 20
- **RX audio load impedance (Ohms):** Default value = 4
- **RX audio maximum power (Watts):** Default value = 1
- **RX conv squelch control [0=no 1=yes]:** Default value = 0
- **RX conv squelch preset only [0=no 1=yes]:** Default value = 0
- **RX set radio volume [0=no 1=yes]:** Default value = 1
- **RX tolerance for setting volume (% error):** Default value = 20

Also set all appropriate GN parameters (see "**General (GN) Parameters**" on page 151).

### Pass/fail limits Used

- **12. RX conv threshold sq SINAD @ opening (dB):**  
Default values: LL=none UL=8
- **13. RX conv threshold squelch sensitivity (mV):**  
Default values: LL=none UL=.5
- **14. RX conv tight squelch sensitivity (mV):**  
Default values: LL=none UL=1
- **15. RX conv tight squelch SINAD @ opening (dB):**  
Default values: LL=15 UL=none
- **29. TX current drain (Amps):** Default values: LL=none UL=7.5

---

## Test\_16: RX conv squelch blocking

*This test is only used for conventional operation with an external variable squelch control.*

This test measures the tendency of the receiver squelch circuit to close in the presence of modulation on the carrier.

The carrier is set to the rated deviation, with an RF carrier level 12 dB above the tight squelch pass/fail limit. The radio's volume is adjusted to 10% of maximum, and the modulation rate is stepped from 300 Hz to 3 kHz.

Blocking is determined by comparing the audio levels with the squelch tight (maximum) and open (minimum). The difference is expressed in dB.

### Analyzer Settings

- Filter 1: 50 Hz HPF
- Filter 2: 15 kHz LPF
- De-emphasis: Off
- Detector: RMS



## Parameters Used

### Conventional Radios Only

- **RT external RF pad and cable loss (dB):** Default value = 0
- **RT full rated system deviation (kHz):** Default value = 4.5
- **RT standard RF input level (mV)** Default value = 20
- **RX audio load impedance (Ohms):** Default value = 4
- **RX audio maximum power (Watts):** Default value = 1
- **RX conv squelch blocking step frequency (kHz):**  
Default value = 0.5
- **RX conv squelch control [0=no 1=yes]:** Default value = 0
- **RX conv squelch preset only [0=no 1=yes]:** Default value = 0
- **RX set radio volume [0=no 1=yes]:** Default value = 1
- **RX tolerance for setting volume (% error):** Default value = 20

Also set all appropriate GN parameters (see "**General (GN) Parameters**" on page 151).

### Pass/fail limits Used

- **11. RX conv squelch blocking (dB):** Default values: LL=none UL=10
- **14. RX conv tight squelch sensitivity (mV):**  
Default values: LL=none UL=1

---

## Test\_17: RX squelch opening with signaling

*This test is only performed on conventional radios with CDCSS or CTCSS squelch operation, and on trunked radios using Group, Emergency, or Individual call types. It is not performed on trunked voice guard call types.*

This test determines the carrier level needed to unsquelch the receiver's audio when subaudible signaling is used. SINAD is also measured at the squelch opening point. The carrier is modulated at a 1 kHz rate, at 60% of rated deviation. The audio level (volume) is set to maximum rated power.

### Analyzer Settings

- Filter 1: 300 Hz HPF
- Filter 2: 3 kHz LPF
- De-emphasis: Off
- Detector: RMS

### Parameters Used

#### Conventional Radios Only

- **RX conv CT/CDCSS deviation (kHz):** Default value = 0.75
- **RX conv squelch control [0=no 1=yes]:** Default value = 0
- **RX conv squelch preset only [0=no 1=yes]:** Default value = 0

#### Trunked Radios Only

- **RT trunked invert [0=no 1=rx 2=tx 3=both]:** Default value = 0
- **RT trunked signaling deviation, high speed (kHz)**  
Default value= 3
- **RT trunked signaling deviation, subaudible (kHz)**  
Default value=.75

### Conventional and Trunked Radios

- **RT external RF pad and cable loss (dB):** Default value = 0
- **RT full rated system deviation (kHz):** Default value = 4.5
- **RT standard RF input level (mV)** Default value = 20
- **RX audio load impedance (Ohms):** Default value = 4
- **RX audio maximum power (Watts):** Default value = 1
- **RX set radio volume [0=no 1=yes]:** Default value = 1
- **RX tolerance for setting volume (% error):** Default value = 20

Also set all appropriate GN parameters (see "**General (GN) Parameters**" on page 151).

### Pass/fail limits Used

- **7. RX conv CT/CDCSS squelch opening level (mV):** Default values: LL=none UL=.3
- **8. RX conv CT/CDCSS squelch SINAD at opening (dB):**  
Default values: LL=none UL=12
- **19. RX trunked squelch opening level (mV):**  
Default values: LL=none UL=.3
- **20. RX trunked squelch SINAD at opening (dB):**  
Default values: LL=10 UL=none

---

## Test\_18: RX audio sensitivity

*This test is not performed on trunked voice guard call types.*

This test measures the receiver's maximum audio level with an applied carrier at 40% of rated modulation at a 1 kHz rate.

### Analyzer Settings

- Filter 1: 300 Hz HPF
- Filter 2: 3 kHz LPF
- De-emphasis: Off
- Detector: RMS

### Parameters Used

#### Conventional Radios Only

- **RX conv CT/CDCSS deviation (kHz):** Default value = 0.75
- **RX conv squelch control [0=no 1=yes]:** Default value = 0
- **RX conv squelch preset only [0=no 1=yes]:** Default value = 0

#### Trunked Radios Only

- **RT trunked invert [0=no 1=rx 2=tx 3=both]:**  
Default value = 0
- **RT trunked signaling deviation, high speed (kHz)**  
Default value = 3
- **RT trunked signaling deviation, subaudible (kHz)**  
Default value = .75

### Conventional and Trunked Radios

- **RT external RF pad and cable loss (dB):** Default value = 0
- **RT full rated system deviation (kHz):** Default value = 4.5
- **RT standard RF input level (mV)** Default value = 20
- **RX audio load impedance (Ohms):** Default value = 4
- **RX audio maximum power (Watts):** Default value = 1
- **RX set radio volume [0=no 1=yes]:** Default value = 1

Also set all appropriate GN parameters (see "**General (GN) Parameters**" on page 151).

### Pass/fail limits Used

- **6. RX audio output @40% of full rated dev (Watts):**  
Default values: LL=3 UL=none

---

## Test\_19: RX conv signal displacement bw

*This test is not performed on trunked radios.*

This test determines the amount of frequency offset that still provides usable receiver sensitivity for conventional radios.

The carrier level is set to 6 dB above the usable sensitivity value (typically 12 dB SINAD), and then the carrier frequency is moved above and below the center frequency until usable sensitivity SINAD is achieved in each direction. The minimum variation in frequency (positive or negative) required to re-establish usable sensitivity SINAD is the returned value. For example, if lowering the center frequency 1.5 kHz produces 12 dB SINAD, and raising the center frequency 2 kHz produces 12 dB SINAD, the returned value is **1.5 kHz** (the lesser of the two changes needed for 12 dB SINAD).

### Analyzer Settings

- Filter 1: 300 Hz HPF
- Filter 2: 3 kHz LPF
- De-emphasis: Off
- Detector: RMS

## Parameters Used

### Conventional Radios Only

- **RT external RF pad and cable loss (dB):** Default value = 0
- **RT full rated system deviation (kHz):** Default value = 4.5
- **RT standard RF input level (mV)** Default value = 20
- **RX audio load impedance (Ohms):** Default value = 4
- **RX audio maximum power (Watts):** Default value = 1
- **RX conv squelch control [0=no 1=yes]:** Default value = 0
- **RX conv squelch preset only [0=no 1=yes]:** Default value = 0
- **RX set radio volume [0=no 1=yes]:** Default value = 1
- **RX tolerance for setting volume (% error):** Default value = 20

Also set all appropriate GN parameters (see "**General (GN) Parameters**" on page 151).

### Pass/fail limits Used

- **16. RX conv variation of sens delta freq (kHz):**  
Default values: LL=1.5 UL=none
- **21. RX usable sensitivity (mV):** Default values: LL=none UL=.2
- **22. RX usable sensitivity SINAD level (dB):**  
Default values: LL=8 UL=none

---

## Test\_20: RX quick test

*This test is not performed on trunked voice guard call types.*

This test is a combination of several receiver tests. Refer to the individual test descriptions for more information on what each test measures and how it is performed.

The tests are performed in the following order:

1. **Test\_18: RX audio sensitivity**
2. **Test\_12: RX audio distortion**
3. **Test\_14: RX usable sensitivity**
4. **Test\_11: RX hum and noise**
5. **Test\_15: RX conv audio squelch sensitivity**
6. **Test\_16: RX conv squelch blocking**
7. **Test\_13: RX frequency response**
8. **Test\_17: RX squelch opening with signaling**

### Analyzer Settings

Analyzer settings change according to the test performed. Refer to the individual test descriptions for more information.

### Parameters Used

The parameters required for this test are a combination of all the parameters needed for the individual tests listed above.

#### Conventional Radios Only

- **RX conv CT/CDCSS deviation (kHz):** Default value = 0.75
- **RX conv squelch blocking step frequency (kHz):**  
Default value = 0.5
- **RX conv squelch control [0=no 1=yes]:** Default value = 0
- **RX conv squelch preset only [0=no 1=yes]:** Default value = 0



### Trunked Radios Only

- **RT trunked invert [0=no 1=rx 2=tx 3=both]:** Default value = 0
- **RT trunked signaling deviation, high speed (kHz)**  
Default value= 3
- **RT trunked signaling deviation, subaudible (kHz)**  
Default value=.75

### Conventional and Trunked Radios

- **RT external RF pad and cable loss (dB):** Default value = 0
- **RT full rated system deviation (kHz):** Default value = 4.5
- **RT standard RF input level (mV)** Default value = 20
- **RX audio freq response step frequency (kHz):**  
Default value = 0.5
- **RX audio load impedance (Ohms):** Default value = 4
- **RX audio maximum power (Watts):** Default value = 1
- **RX set radio volume [0=no 1=yes]:** Default value = 1
- **RX tolerance for setting volume (% error):** Default value = 20

Also set all appropriate GN parameters (see "**General (GN) Parameters**" on page 151).

## Pass/fail limits Used

The pass/fail limits required for this test are a combination of all the pass/fail limits needed for the individual tests.

- **1. RX audio distn 17 dB below rated power (%):**  
Default values: LL=none UL=5
- **2. RX audio distortion (%):** Default values: LL=none UL=10
- **3. RX audio freq resp delta from 6dB/oct (dB):**  
Default values: LL=-8 UL=2
- **4. RX audio freq response roll <.5 kHz (dB/oct):**  
Default values: LL=none UL=6
- **5. RX audio freq response roll>2.5 kHz (dB/oct):**  
Default values: LL=none UL=6
- **6. RX audio output @40% of full rated dev (Watts):**  
Default values: LL=3 UL=none
- **7. RX conv CT/CDCSS squelch opening level (mV):**  
Default values: LL=none UL=.3
- **8. RX conv CT/CDCSS squelch SINAD at opening (dB):** Default values: LL=none UL=12
- **9. RX conv hum and noise squelched (dB):**  
Default values: LL=60 UL=none
- **10. RX conv hum and noise with signaling (dB):**  
Default values: LL=30 UL=none
- **11. RX conv squelch blocking (dB):**  
Default values: LL=none UL=10
- **12. RX conv threshold sq SINAD @ opening (dB):**  
Default values: LL=none UL=8
- **13. RX conv threshold squelch sensitivity (mV):**  
Default values: LL=none UL=.5
- **14. RX conv tight squelch sensitivity (mV):**  
Default values: LL=none UL=1

- **15. RX conv tight squelch SINAD @ opening (dB):**  
Default values: LL=15 UL=none
- **17. RX hum and noise unsquelched (dB):**  
Default values: LL=30 UL=none
- **19. RX trunked squelch opening level (mV):**  
Default values: LL=none UL=.3
- **20. RX trunked squelch SINAD at opening (dB):**  
Default values: LL=10 UL=none
- **21. RX usable sensitivity (mV):**  
Default values: LL=none UL=.2
- **22. RX usable sensitivity SINAD level (dB):**  
Default values: LL=8 UL=none

---

## Test\_21: TX quick test

This test is a combination of several transmitter tests. However, only Test\_02 *TX frequency error*, Test\_03 *TX output power*, and Test\_10 *TX signaling deviation & freq/code* are performed on trunked voice guard call types. Refer to the individual test descriptions for more information on what each test measures and how it is performed.

The tests are performed in the following order:

1. **Test\_02: TX frequency error**
2. **Test\_03: TX output power**
3. **Test\_07: TX microphone sensitivity**
4. **Test\_04: TX modulation limiting**
5. **Test\_08: TX FM hum and noise**
6. **Test\_06: TX audio distortion**
7. **Test\_05: TX audio frequency response**
8. **Test\_09: TX residual AM hum and noise**
9. **Test\_10: TX signaling deviation & freq/code**

---

### NOTE:

Halfway through the test, the software automatically dequeys the transmitter and rekeys it so the radio “turn-off-time” does not shut down the transmitter.

---

## Analyzer Settings

Analyzer settings change according to the test performed. Refer to the individual test descriptions for more information.

## Parameters Used

The parameters required for this test are a combination of all the parameters needed for the individual tests listed above.

### Conventional Radios Only

- **RX conv CT/CDCSS deviation (kHz):** Default value = 0.75
- **TX conv CT/CDCSS control [0=no, 1=yes]:** Default value = 0

### Trunked Radios Only

- **RT trunked invert [0=no 1=rx 2=tx 3=both]:** Default value = 0
- **RT trunked signaling deviation, high speed (kHz)**  
Default value= 3
- **RT trunked signaling deviation, subaudible (kHz)**  
Default value=.75

### Conventional and Trunked Radios

- **RT external RF pad and cable loss (dB):** Default value = 0
- **RT full rated system deviation (kHz):** Default value = 4.5
- **RT high supply voltage (Vdc):** Default value = 16.8
- **RT low supply voltage (Vdc):** Default value = 10.8
- **RT nominal supply voltage (Vdc):** Default value = 13.8
- **RT signaling filter 1 opt [0=no 1=yes]** Default value = 1
- **RT standard RF input level (mV)** Default value = 20
- **TX audio distn % full rated system dev (%):**  
Default value = 60
- **TX audio freq response start frequency (kHz):**  
Default value = 0.3
- **TX audio freq response step frequency (kHz):**  
Default value = 0.5
- **TX audio frequency response stop frequency (kHz):**  
Default value = 3
- **TX de-key between TX tests [0=no 1=yes]:** Default value = 1
- **TX mic sens set and measure [0=no 1=yes]** Default value = 0
- **TX modulation limiting sweep step freq (kHz):**  
Default value = 2.7
- **TX power high/low switch [0=no 1=yes]:** Default value = 0
- **TX user/system key UUT [0=user 1=sys]:** Default value = 0

Also set all appropriate GN parameters (see "**General (GN) Parameters**" on page 151).

## Pass/fail limits Used

- **23. TX audio distortion (%):** Default values: LL=none UL=10
- **24. TX audio response delta from 6 dB/oct (dB):**  
Default values: LL=-8 UL=2
- **25. TX audio freq response roll <.5 kHz (dB/oct):**  
Default values: LL=none UL=6
- **26. TX audio response roll >2.5 kHz (dB/oct):**  
Default values: LL=none UL=6
- **27. TX conv CT/CDCSS deviation (kHz):**  
Default values: LL=.5 UL=1
- **28. TX conv CTCSS frequency error (%):**  
Default values: LL=-5 UL=5
- **29. TX current drain (Amps):** Default values: LL=none UL=7.5
- **30. TX deviation if set and measure mic sens (kHz):**  
Default values: LL=2.5 UL=3.5
- **31. TX FM hum and noise (dB):**  
Default values: LL=30 UL=none
- **32. TX frequency error (ppm):** Default values: LL=-2.5 UL=2.5
- **33. TX microphone sensitivity (mVrms):**  
Default values: LL=100 UL=150
- **34. TX modulation limiting (kHz):**  
Default values: LL=none UL=5
- **35. TX output power (Watts):** Default values: LL=10 UL=17
- **36. TX output power at high supply (Watts):**  
Default values: LL=10 UL=17
- **37. TX output power at high supply low switch (Watts):** Default values: LL=5  
UL=10
- **38. TX output power at low supply (Watts):**  
Default values: LL=10 UL=17
- **38. TX output power at low supply (Watts):**  
Default values: LL=5 UL=10
- **40. TX output power low switch setting (Watts):**  
Default values: LL=5 UL=10

- **41. TX residual AM hum and noise (%AM):**  
Default values: LL=none UL=2
- **42. TX trunked deviation, low speed (kHz):**  
Default values: LL=.5 UL=1
- **43. TX trunked deviation, high speed (kHz):**  
Default values: LL=2.0 UL=4.0

---

## Test\_22: RT manual test

The Receiver/Transmitter manual test allows you to select from several RF and AF measurements. Once selected, measurements are continually displayed and updated, allowing you to change radio settings and observe the effects.

As the test is started, a test 'flowchart' and test parameters are displayed. Functions are assigned to each USER key to select the desired test or other operation. After selecting a USER key, test instructions and measurements are displayed.

The receiver/transmitter manual test can be set to test group, emergency, individual, or voice guard call types. The display on the flow chart indicates what call type the software is set to test.

You can change various radio parameters during the tests (Working Channel Number, Logical ID, Group ID, Control Channel Number, Site ID, and Call Type) using the **Chg Parm**s function. This allows you to change radio information during the test instead of restarting the test each time you want to change radio settings. When the test is completed, these parameter changes are noted on the display for your information and are saved in the program in common RAM.

If you already know the control and working channel frequencies, the software can read the unit's Logical ID and Group ID, for trunked channels only. The software reads the unit's Caller ID and Callee ID for individual call types. This function is called **Read UUT**.

### To Read UUT:

1. Press KG (**Chg Parm**s)
2. Press KG (**More**)
3. Press k3 (**Read UUT**)

This will automatically insert the data in the Logical ID and Group ID fields, or Caller ID and Callee ID fields for individual calls.

---

### **AUDIO CONNECTIONS**

You can perform a manual SINAD measurement without audio connections to the HP aC/D by listening to the audio while adjusting the RF level. However, no other audio measurements can be made without audio connections from your radio to the HP aWAY/D. Refer to the Radio and External Hardware diagram at the start of [chapter 4, "Making Connections"](#).



The following measurements are available in this test:

- Transmitter measurements - select k2 (**Test TX**).
  - TX Power
  - TX Frequency Error
  - TX Deviation
  - TX Trunked Voice Guard High Speed Data. The voice guard transmitted data can be viewed on the scope during transmitter measurements. Select k2 (**VIEW DATA**), then select **SCOPE** from the **TO SCREEN** menu. After viewing the data, press the **TESTS** key, then press k2 (**Continue**) to continue tests.
  - TX signaling data - for CTCSS and CDCSS radios. Press the **Meas Data** key during the test for these measurements (trunked radios are read automatically while keying the radio).
  - TX audio level - you may use the knob to adjust the audio level. Press **Aud Step** to adjust the audio level step size. Press **Aud Level** to set the initial level.
- Receiver measurements - select k1 (**Test RX**). *Receiver measurements are not supported for voice guard call types.* If the correct audio level is not detected by the HP 8920A,D, you are prompted to press the **User** or HP 8920A USER key. If you press **User**, you can adjust the RF level using the knob and listen to the SINAD level on your radio. This is the extent of the audio measurements in this case. If you press HP 8920, a meter is displayed and you are prompted to adjust the audio level. Once the audio level is adjusted, the SINAD level is displayed, and several USER keys are displayed to make the following measurements:
  - RX SINAD - displayed at the start of testing. You can also press **Mes Sinad** if you have been making other audio measurements in this test (such as Audio Power).
  - RF Level -you may use the knob to adjust the RF level. Press **RF Step** to adjust the RF level step size. Press **RF Level** to set the initial level.
  - Audio Power - press **Mes Aud**.
  - Audio Distortion - press **Mes Aud**.
- Channel Operation (trunked radios only) - press **Chk Chans** to verify a handshake on each trunked channel for the selected system. The **Test?** column in the **Channel Information** (or Edit Frequencies) screen must be set to **Yes** for each trunked channel you want to check.

## Analyzer Settings

### TX Tests

- Detector: Pk+
- Filter 1: <20 Hz HPF
- Filter 2: 3 kHz LPF
- De-emphasis: 750  $\mu$ s

### RX Tests

- SINAD
  - Detector: RMS
  - Filter 1: 300 Hz HPF
  - Filter 2: 3 kHz LPF
  - De-Emphasis: Off
- Distortion and AF Power
  - Detector: RMS
  - Filter 1: 300 Hz HPF
  - Filter 2: 15 kHz LPF
  - De-emphasis: Off

## Parameters Used

### Conventional Radios Only

- **RX conv CT/CDCSS deviation (kHz):** Default value = 0.75
- **RX conv squelch control [0=no 1=yes]:** Default value = 0
- **RX conv squelch preset only [0=no 1=yes]:** Default value = 0
- **TX conv CT/CDCSS control [0=no, 1=yes]:** Default value = 0

### Trunked Radios Only

- **RT trunked invert [0=no 1=rx 2=tx 3=both]:**  
Default value = 0
- **RT trunked signaling deviation, high speed (kHz)**  
Default value = 3
- **RT trunked signaling deviation, subaudible (kHz)**  
Default value = .75

### Conventional and Trunked Radios

- **RT external RF pad and cable loss (dB):** Default value = 0
- **RT full rated system deviation (kHz):** Default value = 4.5
- **RT standard RF input level (mV)** Default value = 20
- **RX audio load impedance (Ohms):** Default value = 4
- **RX audio maximum power (Watts):** Default value = 1
- **RX set radio volume [0=no 1=yes]:** Default value = 1
- **RX tolerance for setting volume (% error):** Default value = 20
- **TX de-key between TX tests [0=no 1=yes]:** Default value = 1
- **TX user/system key UUT [0=user 1=sys]:** Default value = 0

Also set all appropriate GN parameters (see "**General (GN) Parameters**" on page 151).

### Pass/fail limits Used

- **21. RX usable sensitivity (mV):** Default values: LL=none UL=.2
- **28. TX conv CTCSS frequency error (%):**  
Default values: LL=-5 UL=5

---

## Test\_23: TX transient frequency behavior

This test is a measure of the difference between the actual transmitter frequency and the assigned channel frequency as a function of time, as the transmitter RF power is turned on and off. It sets up the system so the user can manually take the measurement and interpret the results themselves using a visual display which appears on the screen.

### Analyzer Settings

- IF Filter: 230 KHz
- Squelch: Fixed
- Filter 1: 300 Hz HPF
- Filter 2: 3 KHz LPF
- De-emphasis: 750  $\mu$ s
- Detector: Pk +
- All Ranges: Held

### Parameters Used

#### Conventional Radios Only

- **TX conv CT/CDCSS control [0=no, 1=yes]:** Default value = 0

#### Trunked Radios Only

- **RT trunked signaling deviation, high speed (kHz)**  
Default value= 3
- **RT trunked signaling deviation, subaudible (kHz)**  
Default value=.75

### Conventional and Trunked Radios

- **RT external RF pad and cable loss (dB):** Default value = 0
- **RT standard RF input level (mV)** Default value = 20
- **TX de-key between TX tests [0=no 1=yes]:** Default value = 1
- **TX power high/low switch [0=no 1=yes]:** Default value = 0
- **TX user/system key UUT [0=user 1=sys]:** Default value = 0

Also set all appropriate GN parameters (see "**General (GN) Parameters**" on page 151).

### Pass/fail limits Used

- none (user is prompted to answer yes or no to a "did the UUT pass?" prompt at the completion of the test).

---

## Parameters

Parameters are used to define the conditions under which a test will run. You may edit the parameters to change the default values to meet your specific testing needs and conditions. Parameters may be used in one or more tests.

For information on editing parameters, see "[Customizing Testing](#)" on page 84 in [chapter 5](#).

The list of parameters is arranged alphabetically. The first few capital letters in the title of each parameter indicate what the parameter refers to (see Prefixes and Abbreviations at the beginning of this chapter). :

There are three ways available to enter some General Parameter values; using the parameter table in the Edit Parameter screen, using the System Information Screen, and using the **Channel Info** field in the Channel Information (or Edit Frequency) screen. You may choose whichever method is best suited for your needs. If you have values entered in more than one of the above, the following order of precedence will be used

1. System Information Screen: Has the highest priority of the three methods. (Exception: when testing multiple channels, the parameters entered on the System Information Screen are disregarded. For more detail, see "[Testing Multiple Channels](#)" on page 152 at the beginning of this chapter).
2. Channel Info: (conventional only) Used if values are entered into the **Channel Info** field, and the System Information Screen is not used.
3. Parameter Table: (Edit Parameter screen) Has the lowest priority of the three methods. The parameter table is used only when the information is not entered in the **Channel Info** field, and the System Information Screen is not being used. (Note: parameters which are not General Parameters *will always* be used from this table).

## Parameters Descriptions

### General Parameters

**1. AA use GN value from [0=sys info 1=parm]:**

Default value = 1 (CHANS), 0 (FULL, MANUAL) Determines where initial test information comes from.

**2. GN choose radio type [0=conv 1=trunked]:**

Default value = 1 [0=conv 1=trunked] Specifies the radio type you want to test.

**3. GN conv chan# [0 or 26-50] [0=all chans]:**

Default value = 0 (CHANS), 28 (FULL, MANUAL) Entering **0** causes *all* conventional channels to be tested that have been specified in the Channel Information (or Edit Frequencies) screen as channels 26 to 50.

**4. GN conv RX CDCSS code:**

Default value = 023 Enter the CDCSS digital code number for your conventional channel receiver.

**5. GN conv RX CTCSS freq (Hz) :**

Default value = 71.9 (wideband), 156.7 (narrowband) Enter the CTCSS squelch frequency in Hz for your conventional channel receiver.

**6. GN conv RX squelch[0=CS 1=CTCSS 2=CDCSS]:**

Default value = 0 Specify the squelch type for your conventional channel receiver - Carrier Squelch, Continuous Tone Controlled Squelch System, Continuous Digital Controlled Squelch System.

**7. GN conv TX CDCSS code:**

Default value = 023 Enter the CDCSS digital code number for your conventional channel transmitter.

**8. GN conv TX CTCSS freq (Hz) :**

Default value = 71.9 (wideband), 156.7 (narrowband) Enter the CTCSS squelch frequency in Hz for your conventional channel transmitter.

**9. GN conv TX squelch[0=CS 1=CTCSS 2=CDCSS]:**

Default value = 0 Specify the squelch type for your conventional channel transmitter - Carrier Squelch, Continuous Tone Controlled Squelch System, Continuous Digital Controlled Squelch System.

**10. GN trunked call type [1=GR, 2=EM, 3=IN, 4=VG]:**

Default value = 1 Enter the call type you wish to test. 1=Group Call, 2=Emergency Call, 3=Individual Call, 4=Voice Guard Call. If Individual Call Type is selected, parameter *GN trunked callee ID* must also be set.

**11. GN trunked callee ID:**

Default value = 4093 Enter the Logical ID of the radio your UUT is set to call in an Individual Type Call.

**12. GN trunked control chan# [1-25]:**

Default value = 1 Enter the control channel number for your trunked radio.

**13. GN trunked data rate (bps) :**

Default value = 9600 (wideband), 4800 (narrowband) Enter the data rate for your trunked radio receiver.

**14. GN trunked data standard [4800 or 9600]:**

Default value = 9600 Enter the Data Standard for your trunked radio; 9600 for wideband, 4800 for narrowband.

**15. GN trunked group ID:**

Default value = 2035 (wideband), 2031 (narrowband) Enter the group Identification Number for your trunked radio transmitter.

**16. GN trunked logical ID:**

Default value = 4095 (wideband), 1605 (narrowband) Enter the logical Identification Number for your trunked radio receiver.

**17. GN trunked site ID:**

Default value = 1 (wideband), 2 (narrowband) Enter the site Identification Number for your trunked radio transmitter.

**18. GN trunked working chan# [0 or 1-25] [0=all ch]:**

Default value = 0 (CHANS), 5 (FULL, MANUAL), 4 (narrowband) Entering **0** causes *all* trunked channels to be tested that have been specified in the Channel Information (or Edit Frequencies) screen as channels 1 to 25.



### Test Parameter Descriptions

- **RT external RF pad and cable loss (dB):**

Default value = 0 Enter the total amount of RF attenuation caused by cables, pads (attenuators), or any other external device. This value affects RF level measurements and RF generator settings.

- **RT full rated system deviation (kHz):**

Default value = 4.5 Enter the maximum rated deviation for your radio.

- **RT high supply voltage (Vdc):**

Default value = 16.8 Enter the maximum allowable supply voltage for your radio. *This parameter is only used if a programmable power supply is used.*

- **RT low supply voltage (Vdc):**

Default value = 10.8 Enter the minimum allowable supply voltage for your radio. *This parameter is only used if a programmable power supply is used.*

- **RT nominal supply voltage (Vdc):**

Default value = 13.8 Enter the nominal power supply voltage for your radio *when using a programmable supply.*

- **RT signaling filter 1 opt [0=no 1=yes]**

Default value = 1 Set the value to **1** if your HP 8920A,D is equipped with the optional 400 Hz HPF (HP 8920A option 010).

**NOTE:** If this parameter is set to 1=yes and the filter is not installed, the 300 Hz HPF is used.

- **RT standard RF input level ( $\mu\text{V}$ )**

Default value = 20 Enter the standard RF generator level used to test your receiver. The EIA defines this level as 60 dB above the usable sensitivity for your receiver. For example, if 12 dB SINAD is specified at 0.30  $\mu\text{V}$ , set this value to 300  $\mu\text{V}$ .

- **RT trunked invert [0=no 1=rx 2=tx 3=both]:**  
Default value = 0 (wideband), 1 (narrowband) Enter -
  - 0 if your radio receives and transmits standard (non-inverted) trunking data.
  - 1 if your receiver is set up to receive inverted trunking data, but transmits non-inverted data.
  - 2 if your transmitter is set up to transmit inverted trunking data, but receives non-inverted data.
  - 3 if both the receiver and transmitter are set up to use inverted trunking data.
- **RT trunked signaling deviation, high speed (kHz)**  
Default value = 3 Enter the maximum rated deviation for the trunking high speed signaling data for your radio.
- **RT trunked signaling deviation, subaudible (kHz)**  
Default value = 0.75 Enter the maximum rated deviation for the trunking subaudible low speed signaling data for your radio.
- **RX audio freq response step frequency (kHz):**  
Default value = 0.5 Enter the step size for the audio frequency sweep.
- **RX audio load impedance (Ohms):**  
Default value = 4 Enter the audio output load impedance of your receiver. This value is used by the HP 8920A,D to determine audio power levels during tests.
- **RX audio maximum power (Watts):**  
Default value = 1 Enter the maximum audio output power of your receiver.
- **RX conv CT/CDCSS deviation (kHz):**  
Default value = 0.75 Enter the nominal rated signaling deviation when testing a CTCSS or CDCSS conventional channel. *This parameter is used to set the decoder's level for decoding CDCSS signals.*
- **RX conv sens set and meas [0=no 1=yes]:**  
Default value = 1 Enter **0** to have the RF generator adjust its level until the lower level from pass/fail limit *RX usable sensitivity SINAD level* is reached (method 1). Enter **1** to set the RF generator to the upper limit level from pass/fail limit *RX usable sensitivity* and measure SINAD.

- **RX conv squelch blocking step frequency (kHz):**

Default value = 0.5 Enter the step size for the 300 Hz to 3 kHz modulation rate sweep. The smallest allowed step size is 0.07 kHz.

- **RX conv squelch control [0=no 1=yes]:**

Default value = 0 Set the value to **1** if you want the operator to adjust the radio's squelch during the test. Entering **0** causes the test to use the present squelch setting without asking for operator adjustment.

- **RX conv squelch preset only [0=no 1=yes]:**

Default value = 0 Set the value to **1** if your radio only has a squelch switch that disables squelch or sets it to a preset level. If your radio has a variable squelch control, set this parameter to **0**.

- **RX set radio volume [0=no 1=yes]:**

Default value = 1 Enter **1** to prompt the operator to adjust the radio's volume during certain receiver tests. Entering **0** causes tests to use the present volume setting, reducing operator interaction and test time. However, using the present volume setting may not meet some industry-standard audio level requirements for receiver tests. If the volume is not set correctly, a message is displayed to indicate the volume is not set correctly, and the test will proceed.

- **RX tolerance for setting volume (% error):**

Default value = 20 Enter the audio level adjustment tolerance as a percentage of the maximum audio power (parameter *RX audio maximum power (Watts)*). This value determines how closely you have to adjust the volume during receiver tests.

- **TX audio distn % full rated system dev (%):**

Default value = 60 Enter the percentage of maximum transmitter deviation to use when measuring transmitter distortion. For example, if TX audio distortion for your radio is checked at 60% of full rated deviation, enter **60**.

- **TX audio freq response start frequency (kHz):**

Default value = 0.3 Enter the lowest frequency for the modulation frequency sweep.

- **TX audio freq response step frequency (kHz):**

Default value = 0.5 Enter the frequency step size for the modulation frequency sweep.

- **TX audio frequency response stop frequency (kHz):**

Default value = 3 Enter the highest frequency for the modulation frequency sweep.

- **TX conv CT/CDCSS control [0=no, 1=yes]:**

Default value = 0 Set the value to **1=yes** if your transmitter uses CTCSS or CDCSS squelch control *and* the transmitter's CTCSS or CDCSS system can be turned on and off.

- **TX de-key between TX tests [0=no 1=yes]:**

Default value = 1 (CHANS), 0 (FULL, MANUAL) Enter **1=yes** if you want the transmitter to be de-keyed between transmitter tests (this may be necessary if your transmitter has a transmit time-out feature). Enter **0=no** if you want the transmitter to remain keyed during all transmitter tests. If parameter *TX user/system key UUT* [0=user 1=sys] is set to **0=user**, you are prompted to key and de-key the transmitter during tests. If this parameter is set to **1=sys**, the HP 8920A,D will automatically key and de-key the transmitter when needed.

- **TX mic sens set and measure [0=no 1=yes]**

**Default value = 0:** Enter **1=yes** to use the **TX microphone sensitivity** upper and lower limits (pass/fail limit *TX microphone sensitivity (mVrms)*) to set the microphone input level and measure the resulting transmitter deviation.

- **TX modulation limiting sweep step freq (kHz):**

Default value = 2.7 Enter the frequency step size for the 300 Hz to 3 kHz sweep, or enter **0** if you want to test only at 1 kHz.

- **TX power high/low switch [0=no 1=yes]:**

Default value = 0 Set the value to **1=yes** if your radio has a high/low transmitter power select switch and you want to test both power levels.

- **TX user/system key UUT [0=user 1=sys]:**

Default value = 0 Set the value to **1=sys** if your radio is connected to the HP 8920A,D's MIC/ACC connector to allow the system (HP 8920A,D) to control transmitter keying. Set the value to **0=user** if you are manually keying the transmitter. Connections for the MIC/ACC connector are described in chapter 4 of the *HP 8920A User's Guide*.

- **XX secure frequency info [0=no 1=yes]:**

Default value = 0 Enter **1=yes** if you want to prevent the channel frequencies from being displayed during tests and from being printed during tests if a printer is used. When set to **1**, the operator is prompted to set receive and transmit frequencies to RX=FXXX; TX=RXXX MHz.

**\*GN read login information [0=no 1=yes]:**

Default value = 0 Set the value to **1=yes** if your radio is programmed to transmit login information when it first receives control channel information or when the system or group is changed, and you want the login information. The login information contains the group ID and logical ID. If the login information is successfully read, the software will use the group ID and logical ID from the login instead of from the parameters or **System Information Screen**.

---

**NOTE:** The read login information function is not supported on instruments with firmware lower than **A.12.09**.

---

## Pass/Fail Limits (Specifications)

Pass/Fail Limits define the values a measurement's result is compared against to determine if the UUT meets its specified standards.

For information on editing Pass/Fail Limits, see "[Customizing Testing](#)" on page 84 in [chapter 5](#).

The list of pass/fail limits is arranged alphabetically. The first few capital letters in the title of each pass/fail limit indicate what the pass/fail limit refers to (see Prefixes and Abbreviations at the beginning of this chapter).

Pass/Fail Limits remain in battery-backed-up memory until you select a procedure to run. If you wish to prevent them from being lost when a new procedure is selected you will have to save them in a procedure. See "[Saving a Test Procedure](#)" on page 102 in [chapter 5](#). To print the list of Pass/Fail Limits, see "[To print TESTS screens:](#)" on page 264 in [chapter 8](#).

## Pass/Fail Limit (Specification) Descriptions

### 1. RX audio distn 17 dB below rated power (%):

Default values: LL= none UL= 5 Enter the maximum distortion level allowed with the audio output (volume) set 17 dB below maximum. Only the upper limit is typically used for this measurement; set the lower limit to 0.

### 2. RX audio distortion (%):

Default values: LL= none UL= 10 Enter the maximum distortion level allowed with the audio output (volume) set to maximum. Only the upper limit is typically used for this measurement; set the lower limit to 0.

### 3. RX audio freq resp delta from 6dB/oct (dB):

Default values: LL= -8 UL= 2 Enter the lower and upper limits (in dB) for the audio response 6 dB/octave de-emphasis curve specification for your radio.

### 4. RX audio freq response roll <.5 kHz (dB/oct):

Default values: LL= none UL= 6 Enter the specified audio frequency response roll-off from a true 6 dB/octave de-emphasis curve for modulating frequencies less than 500 Hz (in dB/octave). Enter the upper limit only; the lower limit is typically not used

### 5. RX audio freq response roll>2.5 kHz (dB/oct):

Default values: LL= none UL= 6 Enter the specified audio frequency response roll-off from a true 6 dB/octave de-emphasis curve for modulating frequencies greater than 2.5 kHz (in dB/octave). Enter the upper limit only; the lower limit is typically not used.

**6. RX audio output @40% of full rated dev (Watts):**

Default values: LL= 3 UL= none Enter the minimum audio level that should be present with 40% of full rated deviation and the audio volume level set at maximum. This value is entered as the lower limit; the upper limit is typically not used for this test.

**7. RX conv CT/CDCSS squelch opening level ( $\mu$ V):**

Default values: LL= none UL= 0.3 Enter the maximum carrier level required to open (break) squelch on conventional radios with CTCSS or CDCSS squelch operation. This value is entered as the upper limit; the lower limit is typically not used for this test.

**8. RX conv CT/CDCSS squelch SINAD at opening (dB):**

Default values: LL= none UL= 12 Enter the maximum SINAD level that should be measured at the squelch opening point for conventional radios with CTCSS or CDCSS squelch operation. This value is entered as the upper limit; the lower limit is typically not used for this test.

**9. RX conv hum and noise squelched (dB):**

Default values: LL= 60 UL= none Enter the receiver's fully-squelched hum and noise specification as the lower limit. The upper limit field is typically not used for this pass/fail limit.

**10. RX conv hum and noise with signaling (dB):**

Default values: LL= 30 UL= none Enter the receiver's hum and noise specification when CTCSS or CDCSS signaling is used. This value is entered as the upper limit; the lower limit field is typically not used for this specification.

**11. RX conv squelch blocking (dB):**

Default values: LL= none UL= 10 Enter the maximum difference (in dB) in audio level with squelch tight (maximum) and open (minimum), using a modulated carrier set 12 dB above the tight squelch specification level.

**12. RX conv threshold sq SINAD @ opening (dB):**

Default values: LL= none UL= 8 Enter the maximum SINAD allowed at the RF carrier level required to break (open) squelch (the carrier level is entered in pass/fail limit *RX conv threshold squelch sensitivity*). The value is entered as the upper limit; the lower limit is typically not used.

**13. RX conv threshold squelch sensitivity ( $\mu\text{V}$ ):**

Default values: LL= none UL= 0.5 Enter the maximum RF carrier level required to open (break) squelch when modulated at 60% rated deviation at a 1 kHz rate. The value is entered as the upper limit; the lower limit is typically not used.

**14. RX conv tight squelch sensitivity ( $\mu\text{V}$ ):**

Default values: LL= none UL= 1 Enter the maximum RF carrier level required to open tight (maximum) squelch. The value is entered as the upper limit; the lower limit is typically not used. The industry standard used for this test states that the RF signal required shall be no more than 20 dB greater than the measured reference sensitivity value. For example, if the usable sensitivity of your radio is 1  $\mu\text{V}$ , you would enter 10  $\mu\text{V}$  for this pass/fail limit (a 20 dB increase is a factor of 10).

**15. RX conv tight squelch SINAD @ opening (dB):**

Default values: LL= 15 UL= none Enter the maximum SINAD allowed at the RF level required to break (open) squelch at the tight (maximum) setting (the carrier level is entered in pass/fail limit 14). The value is entered as the lower limit; the upper limit is typically not used.

**16. RX conv variation of sens delta freq (kHz):**

Default values: LL= 1.5 UL= none Enter the amount of carrier frequency change allowed to produce usable SINAD when the original carrier level is set 6 dB above the usable sensitivity level (the lower limit of pass/fail limit *RX usable sensitivity SINAD level (dB)*). The value is entered in the lower limit field; the upper limit is typically not used.

**17. RX hum and noise unsquelched (dB):**

Default values: LL= 30 UL= none Enter the receiver's unsquelched hum and noise specification as the lower limit. The upper limit field is typically not used for this pass/fail limit.

**18. RX stand-by current drain (Amps):**

Default values: LL= none UL= 0.5 Enter the amount of power supply current allowed with the transmitter off and the receiver audio squelched.

**19. RX trunked squelch opening level ( $\mu\text{V}$ ):**

Default values: LL= none UL= 0.3 Enter the maximum carrier level required to open (break) squelch on trunked radios. This value is entered as the upper limit; the lower limit is typically not used for this test.

**20. RX trunked squelch SINAD at opening (dB):**

Default values: LL= 10 UL= none Enter the maximum SINAD level that should be measured at the squelch opening point for trunked radios. This value is entered as the upper limit; the lower limit is typically not used for this test.



**21. RX usable sensitivity ( $\mu$ V):**

Default values: LL= none UL= 0.2 Enter the maximum RF input signal level in  $\mu$ V required for usable audio quality (the SINAD level of pass/fail limit *RX usable sensitivity SINAD level (dB)*). This value is entered in the upper limit field; the lower limit is typically not used.

**22. RX usable sensitivity SINAD level (dB):**

Default values: LL= 8 UL= none Enter the minimum SINAD level required for usable audio quality. The value is entered in the lower limit field; the upper limit is typically not used.

**23. TX audio distortion (%):**

Default values: LL= none UL= 10 Enter the minimum and maximum allowed transmitter distortion. The deviation level associated with this pass/fail limit is entered in parameter *TX audio distn % full rated system dev.*

**24. TX audio response delta from 6 dB/oct (dB):**

Default values: LL= -3 UL= 1 Enter the allowed variation ( $\pm$  dB) in modulation frequency response from a true 6 dB/octave pre-emphasis slope.

**25. TX audio freq response roll <.5 kHz (dB/oct):**

Default values: LL= none UL= 6 Enter the allowed roll-off in transmitter deviation from a true 6 dB/octave pre-emphasis slope with a modulation rate <.5 kHz. Enter the upper limit only; the lower limit is typically not used.

**26. TX audio response roll >2.5 kHz (dB/oct):**

Default values: LL= none UL= 6 Enter the allowed roll-off in transmitter deviation from a true 6 dB/octave pre-emphasis slope with a modulation rate >2.5 kHz. Enter the upper limit only; the lower limit is typically not used.

**27. TX conv CT/CDCSS deviation (kHz):**

Default values: LL= 0.5 UL= 1 Enter the lower and upper deviation limits for the squelch tone or code when testing a conventional channel using CTCSS or CDCSS squelch control.

**28. TX conv CTCSS frequency error (%):**

Default values: LL= -5 UL= 5 Enter the lower and upper frequency error limits for the CTCSS squelch control tone.

**29. TX current drain (Amps):**

Default values: LL= none UL= 7.5 Enter the minimum and maximum power supply current allowed during transmitter tests. If a programmable power supply is used, the software limits the maximum power supply current to your radio to  $1.1 \times$  upper limit value.

**30. TX deviation if set and measure mic sens (kHz):**

Default values: LL= 2.5 UL= 3.5 If parameter *TX mic sens set and measure* [0=no 1=yes] is set to **1=yes**, enter the lower and upper deviation limits for the amount deviation you want to use for the test (typically 60% of rated maximum).

For example, if the maximum rated deviation is 5 kHz, 60% deviation would be 3 kHz. Entering lower and upper limits of 2.5 kHz and 3.5 kHz allows a  $\pm 0.5$  kHz variance.

**31. TX FM hum and noise (dB):**

Default values: LL= 30 UL= none Enter the transmitter's hum and noise specification as the lower limit. The upper limit is typically not used.

**32. TX frequency error (ppm):**

Default values: LL= -2.5 UL= 2.5 Enter the upper and lower limits in parts-per-million (ppm).

$$ppm = \frac{Freq_{error}(Hz)}{Freq_{expected}(MHz)}$$

For example, with an expected carrier of 815.5875 MHz, and a maximum frequency error specification of  $\pm 2$  kHz, the limits would be

$$\frac{2000}{815.5875} = \pm 2.45 ppm$$

**33. TX microphone sensitivity (mVrms):**

Default values: LL= 100 UL= 150 Enter the minimum and maximum voltage level required at the microphone input to produce 60% of full rated system deviation (see [parameter • RT full rated system deviation \(kHz\): Default value = 4.5](#)).

**34. TX modulation limiting (kHz):**

Default values: LL= none UL= 5 Enter the maximum rated transmitter deviation for your radio

**35. TX output power (Watts):**

Default values: LL= 10 UL= 17 Enter the transmitter output power at the nominal power supply voltage.

**36. TX output power at high supply (Watts):**

Default values: LL= 10 UL= 17 Enter the minimum and maximum transmitter output power at the highest rated supply voltage. *This pass/fail limit is only used if a programmable power supply is used.*

**37. TX output power at high supply low switch (Watts):**

Default values: LL= 5 UL= 10 Enter the minimum and maximum transmitter output power expected with the highest allowable power supply voltage and the radio's transmitter high/low switch set to low. *This pass/fail limit is only used if a programmable power supply is used, and if your radio has a high/low output power switch.*

**38. TX output power at low supply (Watts):**

Default values: LL= 10 UL= 17 Enter the minimum and maximum transmitter output power at the lowest rated supply voltage. *This pass/fail limit is only used if a programmable power supply is used.*

**39. TX output power at low supply low switch (Watts):**

Default values: LL= 5 UL= 10 Enter the minimum and maximum transmitter output power expected with the lowest allowable power supply voltage and the radio's transmitter high/low switch set to low. *This pass/fail limit is only used if a programmable power supply is used, and if your radio has a high/low output power switch.*

**40. TX output power low switch setting (Watts):**

Default values: LL= 5 UL= 10 Enter the minimum and maximum transmitter output power expected with the nominal supply voltage and the radio's transmitter high/low switch set to low. *This pass/fail limit is only used if a programmable power supply is used, your radio has a high/low output power switch, and parameter TX power high/low switch [0=no 1=yes] is set to 1=yes.*

**41. TX residual AM hum and noise (%AM):**

Default values: LL= none UL= 2 Enter transmitter residual AM specification as the upper limit. The lower limit is typically not used.

**42. TX trunked deviation, low speed (kHz):**

Default values: LL= 0.5 UL= 1 Enter the lower and upper deviation limits for transmitting trunking data for Group, Emergency, and Individual Call Types.

**43. TX trunked deviation, high speed (kHz):**

Default values: LL=2.5 UL=3.5 Enter the lower and upper deviation limits for transmitting voice guard data in voice guard call types.



---

## Reference (Alphabetical)

This chapter provides detailed descriptions of the features and functions of the HP 11807A,E software. Topics are arranged alphabetically for quick, easy reference.

---

## Conventions Used

Special presentations of text in this manual reflect the appearance of the item being referred to.

Examples of these special presentations are:

TESTS

*A key on the test set.*

**Procedure:**

*Characters displayed on the CRT display.*

k1 (**Run Test**)

*A USER key, in the key column next to the CRT. **Run Test** is displayed on the CRT.*

0.000000

*A field on the CRT where entries can be made.*

*Titles of documentation are printed in italics.*

The term *test set* refers to the HP 8920A,B,D.

In the steps in this manual the following words are used to describe cursor and entry actions:

- **select** refers to pressing the knob after positioning the cursor in front of the appropriate field (**inverse video** area).
- **choose** means to position the cursor in front of an item in the **Choices:** or **To Screen** menu in the lower right corner of the CRT display, and then press the knob.
- **enter** means to use the numeric keypad, and the ENTER key or measurement units keys to make entries to fields. In some procedures, **enter** is used to describe the action of entering characters into a field.

## Channel Information (Frequencies)

Editing test frequencies consists of assigning transmit and receive frequencies to the channel numbers used during tests, and identifying what channels are used when testing multiple channels. You can also specify conventional channel squelch information as an option to using the **System Information Screen** or General (GN) Parameters. The channel information (frequency) table remains in the battery-backed-up memory until you select a Procedure to run. The information you enter is only permanently retained if you save it in a procedure. (See "[Saving a Procedure](#)" on page 269.)

To print the channel information table, see "[To print TESTS screens:](#)" on page 264.

## Specifying Channel Numbers

### Trunked Channels

The first 25 channel numbers (1-25) on this screen correspond to the control and working channel numbers for your **trunked** system. You select the control or working channel number (**Chan#**) on this screen, and then enter the *mobile's* corresponding channel receive and transmit frequencies.

For example, if repeaters 1, 2, and 3 of your trunked system use channels 384, 385 and 386, you would enter the corresponding *mobile* transmit and receive frequencies like this -

Chan#	RX Freq (MHz) Sq Freq/Code	TX Freq (MHz) Sq Freq/Code	Test?	Prime?
1	860.5875	815.5875	Yes	Yes
2	860.6125	815.6125	Yes	Yes
3	860.6375	815.6375	Yes	Yes

### Conventional Channels

Channel numbers 26-50 (**Chan#**) shown on this screen correspond to conventional channels, but are *not* the same as the official FCC assigned channel numbers used to program your radio. They are arbitrary numbers which you define, and should keep record of.

## Determining ‘Test?’ and ‘Prime?’ Settings

Two attributes are associated with each channel that determine when it may be used to test radios: Test? and Prime?

**Prime?** This attribute determines which tests in a procedure are performed on that channel. When set to **Yes**, all the tests in the procedure are performed on that channel, for single channel testing. When set to **No**, only the tests in the **Order of Tests** (Edit Seqn) screen with **Yes** in the **All Chans?** column are performed on that channel, for single channel testing.

**Test?** This attribute determines whether a channel is tested when testing multiple channels during the same procedure. See the following section, "[To Test Multiple Channels](#)" on page 226. This attribute is also used to specify what trunked channels are checked using the **Chk Chans** function in **Test\_22: RT manual test**.

The **All Chans** field in the **Order of Tests** (Edit Seqn) screen interacts closely with the **Test?** and **Prime?** fields on the **Channel Information** (Edit Frequency) screen. The following table shows how to properly configure these settings according to your testing needs at the time. Note that each testing need has more than one possible configuration.



**Table 3**

Testing Need	Necessary Field Settings		
	All Chan	Test	Prime
Single Channel	Yes	x <sup>1</sup>	x <sup>1</sup>
Single Channel	No	x <sup>1</sup>	yes
Multiple Channels	Yes	Yes	x <sup>1</sup>
Multiple Channels	No	Yes	Yes
Check Channels (Test 22)	Yes	Yes	x <sup>1</sup>
Check Channels (Test 22) <sup>2</sup>	No	Yes	Yes

1. Either yes or no
2. The All Chan and Prime settings enable entry into Test 22. Either All Chan or Prime must be set to yes to enter Test 22.

## To Test Multiple Channels

Multiple channel testing is initiated by using either of the following methods:

- To use the **System Information Screen**, set parameter **AA use GN value from [0=sys info 1=parm]** to **0=sys info**.
  - For a trunked system: set the working channel number = 0
  - For a conventional system: set the conventional channel number = 0
- To use the Parameter table, set parameter **AA use GN value from [0=sys info 1=parm]** to **1=parm**.
  - For a trunked system: set parameter **GN choose radio type [0=conv 1=trunked]** to **1=trunked**. Then set parameter **GN conv RX squelch [0=CS 1=CTCSS 2=CDCSS]** to **0=CS**.
  - For a conventional system: set parameter **GN choose radio type [0=conv 1=trunked]** to **0=conv**. Then set parameter **GN conv chan # [0=all chans or 26-50]** to **0=all chans**.

---

**NOTE:** Once a multiple channel sequence is started, all selected conventional and trunked channels will be tested.

---

## Channel Information (Optional)

*These fields are not used for trunked radio testing.*

Conventional channel **squelch type and tones/codes** can be entered three ways:

1. Using the **System Information Screen RX squelch type, RX CT tone or CD code, TX squelch type, and TX CT tone or CD code** fields. These fields are only displayed if parameter **AA use GN value from [0=sys 1=parm+]**, is set to **0**.
2. Using the **Sq Freq/Code** (or **RX Chan Info** and **TX Chan Info**) fields on the **Channel Information** (or Edit Frequencies) screen.
3. Using parameters **GN conv RX CDCSS code, GN conv RX CTCSS freq, GN conv RX squelch [0=CS 1=CTCSS 2=CDCSS], GN conv TX CDCSS code, GN conv TX CTCSS freq, and GN conv TX squelch [0=CS 1=CTCSS 2=CDCSS]**. These are only used if parameter **AA use GN value from [0=sys 1=parm]**, is set to **1=parm**.

Information in the “**System Information Screen**” has priority over any squelch information entered in the “**Sq Freq/Code**” (or “**RX Chan Info**” and “**TX Chan Info**”) fields, and in the parameter fields. Additionally, information entered in the “**Sq Freq/Code**” (or “**RX Chan Info**” and “**TX Chan Info**”) fields has priority over the remaining case, setting the squelch using the parameter fields.

### Entering CDCSS Squelch Information

Enter the CDCSS code number using the format **CDXXX**, where XXX is the squelch code. Example -

Chan#	RX Freq (MHz) Sq Freq/Code	TX Freq (MHz) Sq Freq/Code	Test?	Prime?
26	860.5875 CD023	815.5875 CD023	Yes	Yes

### Entering CTCSS Squelch Information

CTCSS tone frequency information can be entered two ways:

- Enter the frequency directly using the format: **CTFRXXX**, where XXX is the squelch tone frequency in hertz. Example using a 100Hz squelch tone -

Chan#	RX Freq (MHz) Sq Freq/Code	TX Freq (MHz) Sq Freq/Code	Test?	Prime?
27	860.6125 CTFR100	815.6125 CTFR100	Yes	Yes

- Enter the equivalent squelch frequency code using the format: **CTXX**, where XX is the squelch frequency code. The equivalent squelch codes are listed in the following table. Example using a 100 Hz squelch tone code -

Chan#	RX Freq (MHz) Sq Freq/Code	TX Freq (MHz) Sq Freq/Code	Test?	Prime?
28	860.6375 CT1Z	815.6375 CT1Z	Yes	Yes

**Table 4                      Squelch Code Tone Equivalents**

<b>CTCSS Tone Frequency (Hz)</b>	<b>Equivalent Channel Info Code</b>	<b>CTCSS Tone Frequency (Hz)</b>	<b>Equivalent Channel Info Code</b>
67.0	XZ	127.3	3A
71.9	XA	131.8	3B
74.4	WA	136.5	4Z
77.0	XB	141.3	4A
79.7	SP	146.2	4B
82.5	YZ	151.4	5Z
85.4	YA	156.7	5A
88.5	UB	162.2	5B
91.5	ZZ	167.9	6Z
94.8	ZA	173.8	6A
97.4	ZB	179.9	6B
100.0	1Z	186.2	7Z
103.5	1A	192.8	7A
107.2	1B	203.5	M1
110.9	2Z	210.7	M2
114.8	2A	218.1	M3
118.8	2B	225.7	M4
123.0	3Z		

## Securing Frequency Information

Parameter *XX secure frequency info* [0=no 1=yes], is used to prevent the channel frequencies from being displayed during tests, and from being printed during tests if a printer is used. When set to **1=yes**, the operator is prompted to set receive and transmit frequencies to **RX=FXXX MHz; TX=RXXX MHz**.

---

**NOTE:**

This parameter has no effect on the **System Information Screen**, or in *Test\_22 Manual Test*. In these places, RX and TX frequencies will be displayed as entered.

You can also prevent viewing and/or tampering with the **Channel Information** screen's information using the **SECURE\_IT** ROM program. See "[Securing a Procedure](#)" on page 273.

---

## Copying Files

Files can be copied from one mass-storage device to another using IBASIC COPY commands. For example, to copy a file from an inserted memory card to the left drive of an external dual-disk drive with HP-IB address 700, press TESTS. Select **IBASIC Cntrl** from the **SET UP TEST SET** list (or **IBASIC** from the **Test Function** field). Position the cursor to the IBASIC command line and select it. Using the character list that appears in the **Choices** menu, enter the following command:

**COPY "MY\_TEST:INTERNAL" TO "MYFILE: ,700,0"** You can copy a file from a memory card to an SRAM memory card by loading the program from the memory card into the test set, inserting an initialized SRAM memory card, and then using the IBASIC SAVE command. Enter the following:

You can list the names of the files stored in a memory card or disk catalog by using the IBASIC CAT command. To display a list of file names on a memory card, enter the following:

**CAT ":INTERNAL" or CAT**

The mass storage powers-up to memory card as a default. If you did not change this setting, then **":INTERNAL"** is optional. If you are entering many characters into the IBASIC command line, you may want to connect a terminal to the test set. See "[Configuration for Terminal or PC Operation](#)" on page 238. You will also want to use a terminal if you have many files to list because file names displayed with the **CAT** IBASIC command scroll past the top of the test set's CRT display and cannot be scrolled down.

IBASIC is used when writing your own programs and is not explained in this manual. If you need to write your own IBASIC programs you may acquire the following manuals:

- HP 8920A,D
  - *HP Instrument Basic User's Handbook*  
HP part number E2083-90601.
  - *HP 8920A Programming Manual*  
HP part number 08920-90220.

- HP 8920B
  - *HP Instrument Basic User's Handbook Version 2.0*  
HP part number E2083-90005.
  - *HP 8920B Programming Manual*  
HP part number 08920-90222.

See also: "[Data Collection \(Saving and Retrieving Test Results\)](#)" on page 232 and "[Initializing a Memory Card](#)" on page 249.

---

## Data Collection (Saving and Retrieving Test Results)

The software has the capability to save test results to an SRAM memory card, to a disk drive, or to a PC.

### Collection to a Memory Card or Disk

You will have to make entries into the **External Devices** (Edit Config) screen to describe the type of data collection you are using.

#### To configure External Devices entries:

1. Press TESTS
2. Select **External Devices** from the **SET UP TEST SET** list (or **Edit Cnfg** from the **Test Function** field).
3. Position the cursor to the **Calling Name** field and select it.
4. Using the list of characters in the **Choices** menu, enter **DATA C** into the **Calling Name** next to **Inst# 1**. The entry will look like:

```
1 DATA C
```

Note: For some SW revisions, DATA C will appear in the **Choices** menu. In this case, you may select DATA C, then Done instead of typing each character individually.

5. Position cursor to the **Addr** field and select it.
6. Using the DATA keypad, enter a number into **Addr**, depending on the type of storage media you will be using (press ENTER when complete):

If you are using a memory card, enter **1** into the **Addr**:

```
1 DATA C 1
```

If you are using a disk drive, enter the HP-IB disk address. For example, if the drive you are using is set to 700, then the display needs to look like:

```
1 DATA C 700
```

Calling names can be entered in any order.



The test software supports data storage on Logical Interchange Format (LIF) and Disk Operating System (DOS) disk formats. Storage can be to any of the following file types:

- ASCII files under LIF
- BDAT files under LIF
- HP-UX files under LIF
- DOS files under DOS

You will be specifying the file type with the entry you make into the **Options** field immediately below **DATA C**. If no file type is entered, and the disk format is LIF, the software will select an HP-UX file type. If no file type is entered, and the disk format is DOS, the software will select a DOS file type. For example, if you are using a DOS file and you are not using an extension on the file name, the entry on this screen will look like:

```
1 DATA C 700
```

If you are using an ASCII, BDAT or HP-UX file, you can specify the number of records allocated to the file. The DOS file is automatically updated as data is stored, so record allocation is not required. If you are using HP-UX files, you will have to enter **REC=** to establish a usable number of records. **REC=20480** sets the size to be the same as the default number of 256 byte records used for ASCII files ( $80 \times 256$ ). You can enter the **REC=** after the file type. For example, to use an ASCII file with 200 records of 256 bytes each, you will enter **ASCII REC=200** into the **Options** field.

**NOTE:**

For some software revisions, **REC=** and **ASCII REC=** will appear in the **Choices** menu. In this case, you may select **REC=** or **ASCII REC=**, enter the number of records using the **DATA keypad, then select Done**, instead of typing in each character individually.

The display will appear as follows:

```
1 DATA C 700
  ASCII REC=200
```

The default number of records, used when no **REC=** entry is made, is 80.

Items in the **Options** field can be separated by a comma or a space.

See "**Initializing a Disk**" on page 241 if using a new disk. See "**Initializing a Memory Card**" on page 249 if using a new memory card. The file types under LIF can be used by the test set's IBASIC controller and some HP workstations. The DOS format is required if you wish to use the disk with a PC.

**Table 5 Data Collection (Saving/Retrieving Tests) Configuration Summary**

Inst#	Calling Name Options	Model	Addr	Description
1	DATA Collection	don't care	7xx <sup>1</sup>	To HP-IB disk drive
1	DATA Collection	don't care	1	To memory card
Options: <sup>2</sup>	File types of ASCII, or BDAT, or (EXT), <sup>3</sup> or blank, <sup>4</sup> REC=xxxxx, (number of records)	don't care	7xx <sup>1</sup>	LIF format LIF format DOS file type DOS or HP-UX file type <sup>4</sup> Number of records
1	DATA Collection	don't care	9	Serial to external computer (laptop)

1. xx = Last two digits of HP-IB address.
2. These options apply to disk drive and memory card data collection. They do not apply when collecting data with Addr=9.
3. A DOS file name extension. For example, the file name may be CELL.EXT.
4. DOS is used if the disk format is DOS. HP-UX is used if the disk format is LIF.

### Retrieving Data from a Memory Card

To retrieve the test results after they have been saved on an SRAM memory card, you will have to run an IBASIC program. The following is a program to transfer data from a memory card to a terminal emulator. You can type the program lines into the IBASIC command line from a terminal emulator. See "[Configuration for Terminal or PC Operation](#)" on page 238.

**To enter the data  
retrieval program:**

1. Press TESTS.
2. Select **IBASIC Cntrl** from the **SET UP TEST SET** list (or **IBASIC** from the **Test Function** field).
3. Position the cursor to the IBASIC command field (large field in the upper part of the display) and select it. From the list of characters in the **Choices** field, enter the following IBASIC program statements and commands.
4. Enter **SCRATCH** to delete the previous IBASIC program. Be sure it's saved first.
5. Enter the following program:

```
10 DIM A$(120)
```

*Sets the string length to 120.*

```
20 ASSIGN @File TO "RES:INTERNAL";FORMAT ON
```

*Opens a path to the memory card file called "RES" (for results).*

```
30 ON ERROR GOTO 80
```

*Exits at end of file if an error is encountered.*

```
40 LOOP
```

*Extracts file contents.*

```
50 ENTER @File;A$
```

*Transfers part of the file to the string.*

```
60 OUTPUT 9;A$
```

*The string is output at the Serial port.*

```
70 END LOOP
```

*Goes back to get more of the file.*

```
80 END
```

*End of the program.*

6. Press k1 (**Run**) to run the entered IBASIC program.

---

***DIFFERENCE  
BETWEEN RUN AND  
RUN TEST***

---

The USER (**Run**) key, assigned as a default key on the TESTS (IBASIC Controller) screen, will start an IBASIC program that is resident in the test set's memory. The USER (**Run Test**) key, assigned as a default key on the TESTS screens, will load and run the program that is called from the **Select Procedure Filename:** and **Select Procedure Location:** entries on the TESTS **Main Menu** screen.

## Collection to a PC

Test results can be output through the serial port. A variety of devices can receive the data. An HP Palmtop computer, PC, laptop, or terminal can be used. A terminal emulator can log the test results to a file. Examples of terminal emulator programs are HP AdvanceLink and ProComm, a product of DataStorm Technologies, Inc.

### For example: Configuring an IBM-Compatible PC with HP AdvanceLink for DOS

1. Load and run HP AdvanceLink on your PC.
2. Use the following tables to set the *Global Configuration*, *Terminal Configuration*, and *Remote Configuration* settings.

**Table 6** Global Configuration Settings

FIELD	SETTING
Keyboard	USASCII
Personality	HP
Language	English
Terminal Mode	Alphanumeric
Remote to	<i>enter PC's serial port #</i>
Printer I/F	None
Memory Size	32K
Plotter I/F	None
HP Mode	Yes
Video Type	<i>Select your display type</i>
Forms Path	<i>Enter path if used</i>
Screen Size	<i>Enter the size</i>

**Table 7 Terminal Configuration Settings**

<b>FIELD</b>	<b>SETTING</b>	<b>FIELD</b>	<b>SETTING</b>
Terminal ID	2392A	Esc Xfer(N)	YES
Local Echo	OFF	ASCII 8 Bits	YES
CapsLock	OFF	FldSeparator	US
Start Col	01	BlkTerminator	RS
Bell	ON	ReturnDef	CR
XmitFnctn(A)	NO	Copy	Fields
SPOW(B)	NO	Type Ahead	NO
InhEolWrp(C)	NO	ROW Size	80
Line/Page(D)	LINE	Host Prmpt Char	D1
InhHndShk(G)	NO	Horiz. Scroll. Incr.	08
Inh DC2(H)	NO	Large [+] Key	+

**Table 8 Remote Configuration Settings**

<b>FIELD</b>	<b>SETTING</b>	<b>FIELD</b>	<b>SETTING</b>
Baud Rate	4800	Chk Parity	NO
Parity/Data Bits	None/8	SR(CH)	LO
Eng Ack	No	Recv Pace	None
Asterisk	OFF	Xmit Pace	None
CS(CB)Xmit	NO		

**To set up for data collection to a PC:**

1. Press TESTS.
2. Select **External Devices** from the **SET UP TEST SET** list (or **Edit Cnfg** from the **Test Function** field).
3. Position the cursor to the **Calling Name** field and select it.
4. Using the list of characters in the **Choices** menu, enter **DATA C** (next to **Inst# 1**):

```
1 DATA C
```

5. Position the cursor to the **Addr** field and select it.
6. Using DATA keypad, enter **9** and press ENTER :

```
1 DATA C 9
```

Calling names can be entered in any order.

### **Configuration for Terminal or PC Operation**

It is preferable to enter long strings of characters into fields using a terminal. The characteristics of the serial port, when used for instrument control from a terminal or terminal emulator, are determined by settings on the test set's I/O CONFIGURE screen.

**Set the following:**

- **Serial In** to **Inst**
- **IBASIC Echo** to **On**
- **Inst Echo** to **On**

Set the remaining configuration entries to match the settings of your terminal or PC program.

**Equivalent Front-Panel Control Characters**

The following table lists the terminal/computer keystrokes that equate to front-panel controls. *Each equivalent character must be preceded by the **Escape** key.*

For example, to remotely access the CONFIGURE screen, you type Esc, C on your terminal/computer. (Be sure to use upper-case C for this example.)

Alternate sequences for 5 commonly-used functions are also available. Hold down the Ctrl (control) key and select the corresponding key for the desired function. (Example: Ctrl/H moves the cursor to the left one space.)

ENTER - ^J or ^M

CANCEL - ^C

BACKSPACE - ^H

KNOB\_TURN\_CW - ^R

KNOB\_TURN\_CCW - ^L

**Table 9 Equivalent Front-Panel Control Characters**

Function	Equiv. ESC Char.	Function	Equiv. ESC Char.	Function	Equiv. ESC Char.
CANCEL	!	SAVE	G	PRESET	i
PERCENT MHZ_V	(	REF_SET	J	INCR_DIV_10	j
S_KHZ_MV	)	METER	K	INCR_SET	k
BACKSPACE	-	AVG	L	INCR_TIMES_10	l
ENTER	.	LO_LIMIT	M	DOWN	m
RELEASE	0	HI_LIMIT	N	UP	n
K1	1	E	R	SEVEN	o
K2	2	F	S	EIGHT	p
K3	3	B	U	NINE	q
K4	4	C	V	FOUR	r
K5	5	D	W	FIVE	s
K1_PRIME	6	A	X	SIX	t
K2_PRIME	7	EEX	Z	ONE	u
K3_PRIME	8	YES_ON_OFF	[	TWO	v
ASSIGN	9	NO_PPM_W	]	THREE	w
KNOB_TURN_CCW	<	RX	a	ZERO	x
KNOB_TURN_CW	>	TX	b	POINT	y
MSSG	A	DUPLEX	c	PLUS_MINUS	z
HELP	B	PREV	d	OHM_PCT_DEL_DBUV	{
CONFIG	C	TESTS_MAIN	e	DB_GHZ_DBM	
HOLD	D	LOCAL	f	MS_HZ_UV	}
PRINT	E	RECALL	g		
ADRS	F	MEAS_RESET	h		



---

## Disks

### Initializing a Disk

If you are starting with a blank disk, you will have to initialize it to the format you have chosen. Disk drives require specific commands to perform initialization. The test set's IBASIC commands to initialize some disks are described here. You should verify that the drive you are using can be controlled by the test set and that you are initializing a disk using a drive or PC that has a compatible format.

#### To initialize a disk to LIF in an HP-IB disk drive:

1. Verify that the test set **Mode** on the I/O CONFIGURE screen is set to **Control**:
  - a. Press TESTS.
  - b. Select **IBASIC Cntrl** from the **SET UP TEST SET** list (or **IBASIC** from the **Test Function** field).
  - c. Position the cursor to the IBASIC command field and select it.
  - d. With the list of characters in the **Choices** menu, enter the following:

**INITIALIZE ":,7xx,y"**

where:

xx = the HP-IB address of the disk drive, and

y = the unit number of the drive.

**To initialize a disk to DOS in an HP-IB drive:** Follow the procedure for the LIF format, replacing the INITIALIZE statement with `INITIALIZE "DOS: ,7xx,y"`.

### Retrieving Data from a Disk

One way to retrieve the test results from a disk is to run an IBASIC program. A program to transfer data from a disk to a terminal emulator is given below. You can type it into the IBASIC command line from the terminal emulator. Be sure your program is saved, because it will be deleted from programmable memory. The file name for this example is "RES". The disk address is 700, and the drive number is 0. The entire file name is `RES: ,700,0`.

**To enter the data  
retrieval program:**

1. Press TESTS.
2. Select **IBASIC Cntrl** from the **SET UP TEST SET** list (or **IBASIC** from the **Test Function** field).
3. Position the cursor to the IBASIC command field (large field in the upper part of the display) and select it. From the list of characters in the **Choices** field, enter the following IBASIC program statements and commands.
4. Enter **SCRATCH** to delete the previous IBASIC program. Be sure it's saved first.
5. Enter the following program:

```
10 DIM A$(120)
```

*Sets the string length to 120.*

```
20 ASSIGN @File TO "RES:,700,0"
```

*Opens a path to the file called "RES" (for results).*

```
30 ON ERROR GOTO 80
```

*Exits at end of file if an error is encountered.*

```
40 LOOP
```

*Extracts file contents.*

```
50 ENTER @File;A$
```

*Transfers part of the file to the string.*

```
60 OUTPUT 9;A$
```

*The string is output at the serial port.*

```
70 END LOOP
```

*Goes back to get more of the file.*

```
80 END
```

*End of the program.*

6. Press k1 (**Run**) to run the entered IBASIC program.

## Exiting a Program

Do not press RX or TX to exit the program. Selecting the RX TEST or TX TEST screen causes signal paths internal to the test set to be modified. If you exit the program to a screen other than RX TEST or TX TEST, the settings necessary to resume testing will be retained.

After you have made the manual settings you want, press the DUPLEX key as a last step before continuing the software. This will cause the test set to be properly set up.

Another way to safely exit is to:

1. Press CANCEL.
2. Press DUPLEX.
3. Press SHIFT SAVE.
4. Using list of characters in the **Choices** menu, enter a register name or number.
5. Select **Done**.
6. Operate the test set manually.
7. Press RECALL.
8. Choose the name of the saved setup.
9. Press TESTS.
10. Press k2 (**Continue**).

---

## HP-IB Control Annunciators

The words, letters, and symbols at the top right corner of the CRT display indicate these conditions:

- **R** indicates remote operation from an external controller or IBASIC program in the test set. This letter will be displayed while the software is running.
- **L** indicates that the test set is listening, and is ready to receive a manual or remote command.
- **T** indicates that the test set is talking to another HP-IB device.
- **S** indicates that a service request has been generated.
- **C** indicates that the test set is currently an active controller. Control mode is set on the I/O CONFIGURE screen. The test set must be a controller if HP-IB peripherals are to be controlled.
- **\*** indicates that an IBASIC program is running, or that the IBASIC controller is executing a command.
- **?** indicates that an IBASIC program is waiting for a user response.
- **-** indicates that the IBASIC program is paused.
- **SHIFT** indicates that the SHIFT key was pressed, and that the next key entry will be shifted. (Press SHIFT again to clear).

---

## Memory Cards

Memory cards are inserted into the slot on the test set's front panel. The memory card is powered by the test set while it is inserted. Arrows printed on the memory card and the test set's front panel indicate the direction and orientation of card insertion.

Memory cards are used to store or retrieve the following:

- Software code
- An HP-supplied Procedure, containing:
  - A default TEST sequence
  - Default test parameter values
  - Default pass/fail limit values
- A Library file
- Procedures you make, optimized for your application
- Data collection files
- Channel Information
- User defined keys

Three types of memory cards are available:

- Static Random Access Memory (SRAM)
  - SRAM cards have read and write capability. SRAM cards can be programmed and read with the test set.
- One-Time Programmable (OTP)
  - Once programmed with a suitable card programmer, OTP cards have read-only capability. OTP cards can be read with the test set, but cannot be programmed with the test set.
- Flash Memory
  - Flash cards have read and write capability. They can only be written to, or programmed with a suitable card reader/programmer. Flash memory cards cannot be written to, or programmed with a test set. Flash memory cards can be read by the test set.

---

**NOTE:** Hewlett-Packard-supplied software code and Hewlett-Packard procedure and library files are typically supplied on either OTP cards or flash cards. Flash cards can be distinguished from OTP cards by a small write protect (WP) switch in the end of the flash cards. SRAM cards also have a write protect or safe switch in the end of the card, but they also use a battery. Software and procedure/library files stored on a flash card cannot be overwritten by a test set regardless of the position of the write protect (WP) switch.

---

**NOTE:** The software memory card can be removed after the program is loaded into the test set memory. The program will remain in memory after a power-down/power-up cycle, until a new program is loaded. Loading a new program will replace the existing program.

---

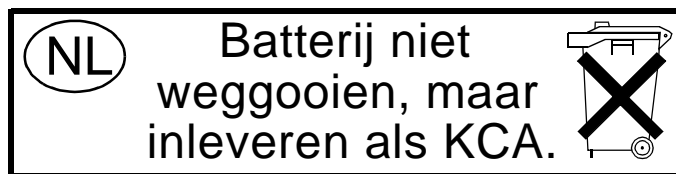

## SRAM Memory Cards

A Static Random Access Memory (SRAM) Card can be used to store test results and procedures you make. The following parts can be used.

**Table 10** SRAM Memory Card Products for HP 8920A,D

Memory	Product
32 kilobytes	HP 85700A
128 kilobytes	HP 85702A
256 kilobytes	HP 85704A
512 kilobytes	HP 85705A

**Table 11** PCMCIA SRAM Memory Card Products for HP 8920B

Memory	Product
64 kilobytes	HP 83230A
256 kilobytes	HP 83233A
1 megabyte	HP 83231A

SRAM memory cards use a lithium battery (For HP 11807A: part number CR 2016 or HP part number 1420-0383. For HP 11807E: part number CR 2025 or HP part number 1420-0509). Programs and data will be retained for over one year if the memory card is stored at 25° C. The memory card is powered by the test set while it is inserted. Replace the battery while the memory card is inserted into a powered-up test set. To retain data and programs, it should be replaced annually. See the *HP 8920 User's Guide*. The write-protect switch on an SRAM memory card will write protect the card when it is set toward the outside of the card.



## Memory Card Storage Space

Procedures use 12-16 records each. A Library uses 20-35 records. A single library must be included on the card. A record is 256 bytes. Approximately 11 kilobytes of overhead is required on each card.

Use the following formula to estimate the storage space needed:

$$\text{Storage Space (in kilobytes)} = (\text{Number of Procedures} \times 4.1) + 20$$

For example, if you want to save ten different procedures, you will need 61 kilobytes of memory. The 64 kilobyte or 128 kilobyte card is sufficient.

The storage space you need for data collection depends on the number of test results that are saved. You will need approximately 4 kilobytes per page of test results that you save. A page of test results is about 57 lines of CRT or printer output.

The storage space of smaller SRAM cards can be quickly used. If you are collecting large quantities of data, data collection using a PC or printer may be preferable.

## Initializing a Memory Card

Initializing HP 11807A cards (Smart Cards) using the TESTS **Save/Delete Procedure** screen automatically defaults to LIF format. Initializing HP 11807E cards (PCMCIA) using the TESTS **Save/Delete Procedure** screen automatically defaults to DOS format. However, initializing cards from the **Save/Delete Procedure** screen is only available on HP 8920B or HP 8920A,D test sets with firmware above revision A.14.00. If these settings do not match your needs, or you have firmware below revision A.14.00, there is another method described below in which you may select the format.

- Press TESTS.
- Select **Save/Delete Procedure** from the CUSTOMIZE TEST PROCEDURE list.
- Insert the SRAM card in the slot on the front panel. (Make sure the switch on the card is not in the write-protected position).
- Press k3 (**Init Card**).
- Press **Yes** if you want to continue.

There are two ways to initialize a memory card to select the format. If you have a terminal emulator attached to the test set, you can type a command into the IBASIC command line. A second way to initialize a card is to run the ROM program RAM\_MNG.

#### To initialize an SRAM card using IBASIC

1. Press TESTS.
2. Select **IBASIC Cntrl** from the **SET UP TEST SET** list (or **IBASIC** from the **Test Function** field).
3. Position the cursor to the IBASIC command line and select it.
4. Using the list of characters under the **Choices** menu, enter the following IBASIC command:

For LIF format: **INITIALIZE ":INTERNAL"**

For DOS format: **INITIALIZE "DOS:INTERNAL"**

#### To initialize an SRAM card using RAM\_MNG

1. Press TESTS.
2. Position the cursor to the **Select Procedure Location** (or **Location**) field and select it.
3. From the **Choices** menu, select **ROM**.
4. Position the cursor to the **Select Procedure Filename** (or **Procedure**) field and select it.
5. From the **Choices** menu, select **IB\_UTIL** (or **RAM\_MNG**).
6. Press k1 (**Run Test**).
7. Follow the displayed instructions.

---

**NOTE:** Loading RAM\_MNG will delete any procedure or program in memory.

### Retrieving Data from a Memory Card

To retrieve the test results after they have been saved on an SRAM memory card, you will have to run an IBASIC program. The following is program to transfer data from a memory card to a terminal emulator. You can type the program lines into the IBASIC command line from a terminal emulator. See "[Configuration for Terminal or PC Operation](#)" on page 238.

**To enter the data  
retrieval program:**

1. Press TESTS.
2. Select **IBASIC Cntrl** from the **SET UP TEST SET** list (or **IBASIC** from the **Test Function** field).
3. Position the cursor to the IBASIC command field (large field in the upper part of the display) and select it. From the list of characters in the **Choices** field, enter the following IBASIC program statements and commands.
4. Enter **SCRATCH** to delete the previous IBASIC program. Be sure it's saved first.
5. Enter the following program:

```
10 DIM A$(120)
```

*Sets the string length to 120.*

```
20 ASSIGN @File TO "RES:INTERNAL";FORMAT ON
```

*Opens a path to the memory card file called "RES" (for results).*

```
30 ON ERROR GOTO 80
```

*Exits at end of file if an error is encountered.*

```
40 LOOP
```

*Extracts file contents.*

```
50 ENTER @File;A$
```

*Transfers part of the file to the string.*

```
60 OUTPUT 9;A$
```

*The string is output at the serial port.*

```
70 END LOOP
```

*Goes back to get more of the file.*

```
80 END
```

*End of the program.*

6. Press k1 (**Run**) to run the entered IBASIC program.

---

***DIFFERENCE  
BETWEEN RUN AND  
RUN TEST***

---

The USER (**Run**) key, assigned as a default key on the TESTS (IBASIC Controller) screen, will start an IBASIC program that is resident in the test set's memory. The USER (**Run Test**) key, assigned as a default key on the other TESTS screens, will load and run the program that is called from the **Select Procedure Filename** and **Select Procedure Location** entries on the TESTS (Main Menu) screen.

---

## Parameters

Parameters are values you enter that optimize your use of the test software. Many of the parameters are determined by examining your test needs.

Default values are set into the software. Some of these values are derived from standard methods of measurement and some are derived from the industry standard requirements. Load a Procedure and select the **Test Parameters** screen from the **CUSTOMIZE TEST PROCEDURE** list, to see the default values.

You should verify that parameters are properly set after you select the tests to be placed in your procedure.

Parameters remain in battery-backed-up memory until you select a procedure to run. If you wish to prevent them from being lost when a new procedure is selected, you will have to save them in a procedure. See ["Saving a Procedure" on page 269](#).

To print the parameters list, see ["To print TESTS screens:" on page 264](#).

**To edit a parameter  
value:**

1. Press TESTS.
2. Select **Test Parameters** from the **CUSTOMIZE TEST PROCEDURE** list (or **Edit Parm** from the **Test Function** field).
3. Position the cursor to the **Parm#** field and select it.
4. Rotate the knob to the desired parameter number and select it.
5. Position the cursor to the **Value** field and select it.
6. Enter the desired value using the DATA keypad and press ENTER.
  - Use the ← key to backspace.
  - Press CANCEL to cancel entries and retain the old value.
7. Press k5 (**Main Menu**) (or TESTS) to return to the TESTS screen.

## Pass/Fail Limits (specifications)

Pass/Fail Limits are values you enter that set passing limits for tests. Default values are available in the test software. They have been derived from standard methods of measurement.

Pass/Fail Limits do not have to be changed when you select a test or change the tests in your procedure. Each test has pass/fail limits that apply to it.

You should verify that pass/fail limits are properly set after you select the tests to be placed in your procedure. Lists of the pass/fail limits used by each of the tests are contained in the test descriptions in [chapter 7](#) of this manual. A lock is provided to prevent access to the pass/fail limits. See "[Securing a Procedure](#)" on [page 273](#).

Pass/fail limits remain in the test set's battery-backed-up memory until you select a procedure to run. If you wish to prevent pass/fail limits from being lost when a new procedure is selected, you will have to save them in a procedure. See "[Saving a Procedure](#)" on [page 269](#).

To print the pass/fail limits list, see "[To print TESTS screens:](#)" on [page 264](#).

**To edit a pass/fail  
limit value:**

1. Press TESTS.
2. Select **Pass/Fail Limits** from the **CUSTOMIZE TEST SET** list (or **Edit Spec** from the **Test Function** field).
3. Position the cursor to the **Spec#** field and select it.
4. Rotate the knob to the desired pass/fail limit number and select it.
5. Position the cursor to the **Lower Limit** or the **Upper Limit** field and select it.
6. Enter desired value using the DATA keypad and press ENTER.
  - Use the ← key to backspace.
  - Press CANCEL to cancel entries and retain the old value.
7. Position the cursor to the **Check** field and select it.
8. From the **Choices** menu, select the combination of upper and lower limits to be checked.

---

## Pausing or Stopping a TEST

To pause the program, press CANCEL.

To stop the program, press SHIFT then CANCEL. This performs an IBASIC RESET operation.

---

### *CHANGING SETTINGS WHILE PAUSED*

If you make changes to instrument settings while the program is paused, subsequent operation may be unpredictable. Error messages may or may not be displayed. See ["Exiting a Program" on page 244](#).

---

### To continue a paused program:

1. Press TESTS.
2. Press k1 (**Continue**). The test time is displayed when the test is completed. This time includes the time that the program is paused and the time that it is waiting for connection and inputs to be made. If you are testing through midnight, the test time will not display properly.



---

## Printing

You can print any of the following:

- Test results
- TESTS screens
  - "External Devices" (Edit Cnfg)
  - "Order of Tests" (Edit Seqn)
  - "Channel Information" (Edit Freq)
  - "Pass/Fail Limits" (Edit Spec)
  - "Test Parameters" (Edit Parm)

**How to Print (task list)** There are five basic steps to printing listed below. A detailed description of each of these steps is at the end of this section.

1. Check to see if your printer is supported by the test set (see "[Supported Printers](#)" on [page 257](#)).
2. Determine if your printer requires serial, parallel, or HP-IB connection. Connect the printer to the appropriate port on the test set (see "[Printer Connection](#)" on [page 258](#)).
3. Configure the test set for your printer and its interface (see "[Configuring the Test Set for Printing](#)" on [page 260](#)).
4. Instruct the test set what to print (see "[To print test results:](#)" on [page 261](#)).

## Supported Printers

- HP ThinkJet printer
- HP QuietJet printer
- HP PaintJet printer
- HP DeskJet printer
- HP LaserJet printer
- Epson FX-80 printer
- Epson LQ-850 printer

If you do not have one of these printers, consult your printer's manual for the correct printer settings to emulate one of the supported printers.

## Printer Connection

### HP-IB Connection

An HP-IB printer can be connected to the test set's rear-panel HP-IB connector with an HP-IB cable.

### Serial Connection

A serial printer can be attached to the serial port. See [figure 14](#) . Use the following RJ-11 pins for this connection.

- RJ-11 Pin 2 - test set Receive Data
- RJ-11 Pin 4 - Ground
- RJ-11 Pin 5 - test set Transmit Data

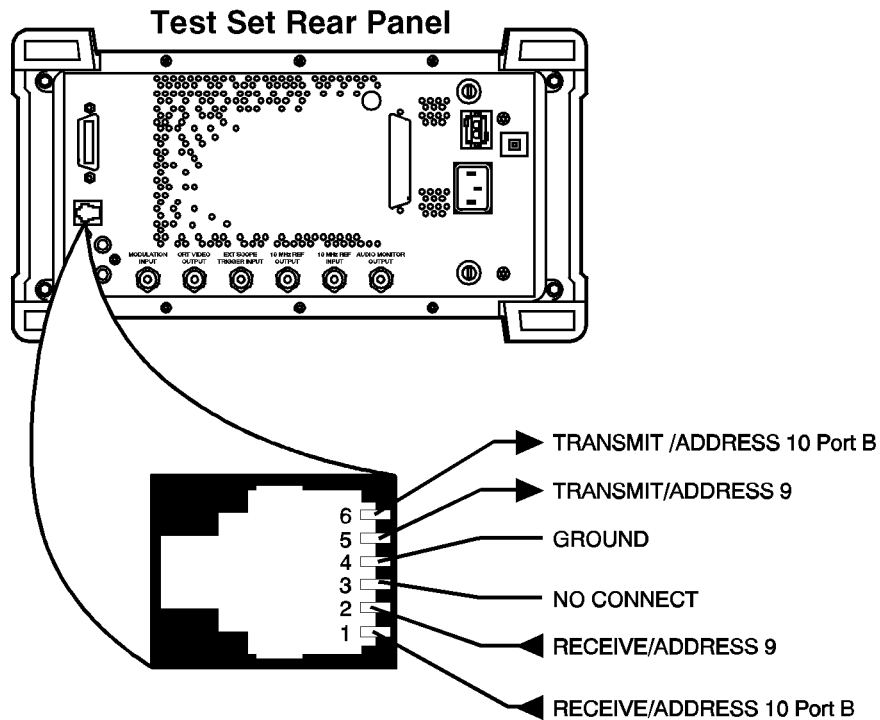
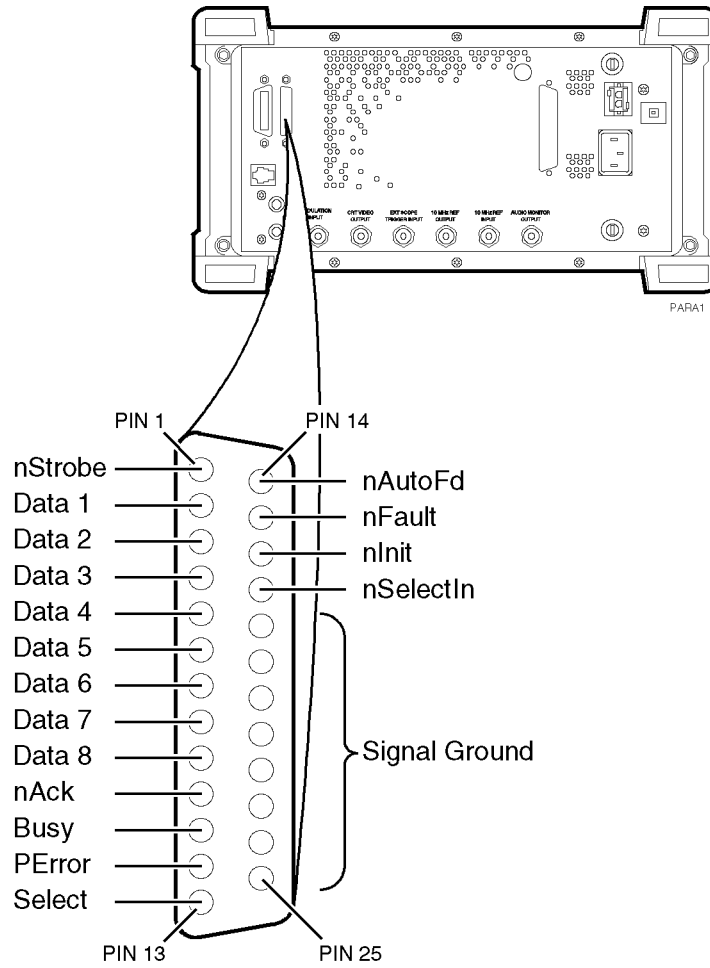

Figure 14 Test Set RJ-11 Serial Port Connections

**Parallel Connection**

A parallel printer can be attached to the parallel port. Use the following **figure 15** for pin information.



**Figure 15**

**Test Set Parallel Port Connections**

## Configuring the Test Set for Printing

If using a serial printer, you cannot use the serial port for other connections at the same time, such as Data Collection (saving test results). Serial port connections are shown earlier in this section.

---

### ***PRINTER SETUP DIFFERENCES***

The HP 8920A,D had several firmware enhancements, which are standard in the HP 8920B. The following **Setup Printer** section applies to users with:

- HP 8920A,D test sets with firmware above revision A.14.00.
- All HP 8920B test sets.

The test set's firmware revision is displayed on the top right corner of the CONFIGURATION screen.

- Press SHIFT CONFIG to display the CONFIGURATION screen and read the firmware revision.

If you have an HP 8920A with firmware revision below A.14.00, refer to the next section, titled "**To Setup Printer**" on page 265. Contact Hewlett-Packard at 1-800-922-8920 for details on upgrading your firmware if desired.

EXCEPTION: If you are using A.xx.xx revision software, you can not use the **Printer Setup** screen regardless of your firmware revision. Refer to the instructions for firmware below A.14.00.

---

## To Setup Printer

### Using HP 8920B, or HP 8920A FW Above Rev. A.14.00 and SW Rev. B.xx.xx

1. Press TESTS
2. Select **Printer Setup** from the **SET UP TEST SET** list.
3. Position the cursor to **Model** and select the desired printer.
4. Position the cursor to **Print Port** and select the desired port.
5. (If HP-IB only) Position the cursor to **Printer Adrs** and enter the HP-IB address for your printer (0-30).
6. Set the following options if desired:
  - Lines/Page (controls the number of lines, 20-120, printed on a page before a form feed is sent to the printer)
  - FF at Start (to cause a form feed at the start of a test sequence)
  - FF at End (to cause a form feed at the end of a test sequence)
7. From the **To Screen** menu, select **More**.
8. From the **Choices** menu, select **IO CONFIG**.
  - For Serial Printing, set the **Serial Baud** field and other serial communications fields listed under it to correspond to your printer's configuration.
  - For HP-IB Printing, set the **Mode** field to **Control**.
9. Press TESTS to return to the TESTS (Main Menu) screen.

### To print test results:

1. Press TESTS
2. Select **Printer Setup** from the **SET UP TEST SET** list.
3. Position the cursor to **Output Results To** and select **Printer**.
4. Position the cursor to **Output Results For** and select **All** if you want all results printed, or **Failures** if you want failures only printed.
5. (Optional) Position the cursor to **Output Heading** and enter your desired heading.

### To send Escape Sequences to the printer

If you have revision B.xx.xx software, you may use the test set to send escape sequences to control printer options such as pitch, margins, paper size, and so forth. The software comes with some pre-defined escape sequences compatible with HP printers, listed below, or you have the option to enter others which are compatible with your printer (use your printer's user's manual for the available print features and corresponding escape sequences). This function is not available with revision A.xx.xx software.

The software already has an implied escape character for the first sequence, you need only to enter the escape sequence following the escape character. However, if you are linking two or more sequences together, you must use the ~ to indicate the escape character between each sequence. If the sequence exceeds the space allotted in the options field, you may continue with additional escape sequences in the next available **Options** field. You must however, still enter **Escape Seq** in the **Calling Name** field and the appropriate address in the **Addr** field for all subsequent entries.

**How to send an  
Escape Sequence:**

1. Press TESTS.
2. Select **External Devices** from the **SET UP TEST SET** list.
3. Position the cursor to the **Inst#** field and select it.
4. Rotate the knob until an empty **Calling Name** field appears, and select it.
5. Position the cursor to the **Calling Name** field and select it.
6. Select **Escape Seq** from the **Choices** menu.
7. Position the cursor to the **Addr** (address) field and select it.
8. Using the DATA keypad, enter **9** for serial printers, **15** for parallel printers, or **70X** for HP-IB printers, then press ENTER. .
9. Position the cursor to the **Options** field (directly under **Calling Name**) and select it.
10. Select the desired escape sequence from the **Choices** menu if applicable, or enter an appropriate sequence using the list of characters below the choices.

**Table 12                      Escape Sequence Definitions for HP Printers**

<b>Escape Sequence</b>	<b>Print Feature</b>
&l66P	Sets page length to 66 lines
&l72P	Sets page length to 72 lines
&l6D	Sets lines per inch to 6 lines
&l8D	Sets lines to inch to 8 lines
(s12h12v6T	Selects 12 characters per inch 12/72 inch character height gothic typeface
&a9L~&l6E	Sets left margin to 9 characters top margin to 6 lines
(s12h12v6T~&a9L~&l6E	Selects 12 characters per inch 12/72 inch character height gothic typeface left margin to 9 characters top margin to 6 lines
&18d88P	Selects 8 lines per inch 88 lines per page
&18d96P	Selects 8 lines per inch 96 lines per page
(s16.67h12V~&a17L~&l6E	Selects 16.67 characters per inch 12/72 inch character height left margin to 17 characters top margin to 6 lines

**To print TESTS screens:**

TESTS screens include:

- "External Devices"
- "Order of Tests"
- "Channel Information"
- "Pass/Fail Limits"
- "Test Parameters"



The same general process is used to print the information for all of the above TESTS screens.

1. Make sure that your printer is properly connected and configured as explained earlier in this section.
2. Press TESTS.
3. Select the **CUSTOMIZE TEST PROCEDURE** screen of your choice.
4. Press k3 (**Print All**) and select it.
5. Press TESTS to return to the TESTS (Main Menu) screen.

## To Setup Printer

### Using HP 8920A FW Below Rev. A.14.00

1. Press TESTS
2. Select **Edit Cnfg** from the **Test Function** field.
3. Position the cursor to the **Inst#** field and select it.
4. Rotate the knob until an empty **Calling Name** field appears, and select it.
5. Position the cursor to the **Calling Name** field and select it.
6. Using the list of characters in the **Choices** menu, enter the word **Printer**. Select **Done** when complete.
7. Position the cursor to the **Model** field and select it (optional).
8. Using the DATA keypad, enter the Model # and press ENTER.
9. Position the cursor to the **Addr** (address) field and select it.
10. Using the DATA keypad, enter **9** for serial printers, **15** for parallel printers, or **70X** for HP-IB printers, then press ENTER. .
11. Position the cursor to the **Options** field (directly under **Calling Name**) and select it.
12. Using the list of characters from the **Choices** menu, the following commands may be entered. Separate the commands with commas (example; **LN=60 , START , END**)
  - **LN** equals the number of printed lines per page.
  - **START** causes a form feed at the start of each printout.
  - **END** causes a form feed at the end of each printout.
13. From the **To Screen** menu, select **More**.
14. From the **Choices** menu, select **IO CONFIG**.

15. For Serial Printers:

- Set the **Serial Baud** field and other serial communications fields listed under it to correspond to your printer's configuration.

16. For HP-IB Printers:

- Position the cursor to the **Mode** field and select it.
- From the **Choices** menu, select **Control**.
- Position the cursor to the **Print Adrs** field and select it.
- Rotate the knob and select the HP-IB address of your printer.
- Position the cursor to the **Print To** field. Pressing knob will toggle the underlined selection. Select to underline **HP-IB**.

17. Press TESTS to return to the TESTS screen.

**To print test results**

1. Make sure that your printer is properly connected and configured as explained earlier in this section.
2. Press TESTS.
3. Position the cursor to the **Output Results To:** field (or the **Output Destination** field). Pressing knob will toggle the underlined selection. Select to underline **Printer**.
4. Position the cursor to the **Output Heading** field and select it.
5. Using the list of characters in the **Choices** menu, enter a printout heading (optional). Select **Done** when the heading is complete.

**To send Escape Sequences to the printer**

If you have revision B.xx.xx software, you may use the test set to send escape sequences to control printer options such as pitch, margins, paper size, and so forth. You may enter sequences which are compatible with your printer (use your printer's user's manual for the available print features and corresponding escape sequences). This function is not available with revision A.xx.xx software.

The software already has an implied escape character for the first sequence, you need only to enter the escape sequence following the escape character. However, if you are linking two or more sequences together, you must use the ~ to indicate the escape character between each sequence. If the sequence exceeds the space allotted in the options field, you may continue with additional escape sequences in the next available **Options** field. You must however, still enter **Escape Seq** in the **Calling Name** field and the appropriate address in the **Addr** field for all subsequent entries.

**How to send an  
Escape Sequence:**

1. Press TESTS.
2. Select **Edit Cnfg** from the **Test Function** field.
3. Position the cursor to the **Inst#** field and select it.
4. Rotate the knob until an empty **Calling Name** field appears, and select it.
5. Position the cursor to the **Calling Name** field and select it.
6. Enter **ESCAPE SEQ** using the characters in the **Choices** menu. Select **Done** when you are finished.
7. Position the cursor to the **Addr** (address) field and select it.
8. Using the DATA keypad, enter **9** for serial printers, **15** for parallel printers, or **70X** for HP-IB printers, then press ENTER.
9. Position the cursor to the **Options** field (directly under **Calling Name**) and select it.
10. Select the desired sequence using the list of characters below the choices.

**To print TESTS screens**

TESTS screens include:

- "Edit Cnfg"
- "Edit Seqn"
- "Edit Freq"
- "Edit Spec"
- "Edit Parm"

The same general process is used to print the information for all of the above TESTS screens.

1. Make sure that your printer is properly connected and configured as explained earlier in this section.
2. Press TESTS.
3. Select the TESTS screen you desire.
4. Press k3 (**Print All**) and select it.
5. Press TESTS to return to the TESTS screen.

---

## Procedures

A procedure is a collection of test parameters, pass/fail limits and a testing order, saved in a file that customizes the test software to a specific application. You may save the file on a memory card or disk.

You do not have to save a test sequence in a procedure. Each test can be stand-alone if desired. After you choose a procedure, you can choose which of the tests you want to run.

When you save a procedure you will only be saving test parameters, pass/fail limits and a testing order. The memory card or disk must also contain a library file. A library file contains the names of all of the test parameters, pass/fail limits and tests that are in the test software. The library you use will be the library that is supplied with your software. When you save your procedure, the library will be automatically saved on the same card or disk.

The procedure(s) supplied with your software will be listed in the **Choices:** column when you select the **Select Procedure Filename:** (or **Procedure**) field. Procedures will be displayed if your software memory card is plugged in.

## Saving a Procedure

After you have set up the test software you can save the setup to an SRAM memory card, disk, or internal RAM memory by doing the following.

The memory card or disk you use must be initialized before its first use. See ["Initializing a Memory Card" on page 249](#) or ["Initializing a Disk" on page 241](#). If you are using a disk drive, you may have to enter the **External Disk Specification** into the TESTS **External Devices** screen (or **Edit Cnfg** screen). It will be used when the **Select Procedure Location:** field on the TESTS screen is **Disk**.

- To save a procedure:**
1. Press TESTS.
  2. Select **Save/Delete Procedure** from the **CUSTOMIZE TEST PROCEDURE** list (or **Proc Mngr** from the **Test Function** field).
  3. Position the cursor to the **Select Procedure Location** (or **Location**) field and select it.
  4. From the **Choices** menu, select the desired location. The media must be initialized before a file can be saved. To initialize an SRAM card (HP 8920B or HP 8920A,D firmware above revision A.14.00 only, otherwise see "[Initializing a Memory Card](#)" on page 249):
    - Insert card in the slot on the test set's front panel.
    - Press k3 (**Init Card**)
    - Press **Yes**. Note: this will delete any procedures or programs from memory.

To initialize a RAM disk, see "Memory Cards/Mass Storage" in the *HP 8920 Programmer's Guide* .

5. Position the cursor to the **Enter Procedure Filename** (or **Procedure**) field and select it.
6. From the list of characters in the **Choices** menu, enter a filename. Filename must be nine characters or less. When filename is complete, position cursor to **Done** and select it. Procedure filenames that already exist on the card will appear at the top of the list of characters.
7. If you selected **Card**, insert an initialized memory card into the slot on the test set's front-panel.
8. Verify that the card or other media is not write-protected. See "[Memory Cards](#)" on page 246.
9. Position the cursor to the **Enter Description for New Procedure** (or **Comment for new procedure**) field and select it. From the list of characters in the **Choices** menu, enter comments. When the comments are complete, position the cursor to **Done** and select it.
10. Position the cursor to the **Procedure Library** (or **Library for new procedure**) field and select **Current** (Current underlined). The name of the Library is displayed on the TESTS screen.
11. Position the cursor to the **Code Location** (or **Program location for new procedure**) field and select it.

From the **Choices** menu, choose memory **Card**, **ROM**, **RAM** or **Disk**. When a procedure is run, the test system will look in this location for a code file if it is not resident in the Test Set's battery-backed-up memory. This location will usually be the software memory card.

12. Press k1 (**Save Proc**) (or position the cursor to the **Action** field and select **Make Procedure**). A procedure will be saved at the location you chose.

## Loading a Procedure

A procedure can be loaded from storage media into the test set's battery-backed-up memory by doing the following.

### To load a procedure:

1. Press TESTS.
2. Position the cursor to the **Select Procedure Location** (or **Location**) field and select it.
3. From the **Choices** menu, choose the desired location where the procedure is stored and select: **Card**, **ROM**, **RAM** or **Disk**.
4. Position the cursor to the **Select Procedure Filename** (or **Procedure**) field and select it.
5. From the **Choices** menu, choose the procedure file that you want to load.
6. Read the **Description** (or **Comment**) field to ensure that the loaded procedure file is the one you want.

## Deleting a Procedure

Procedures can be removed from an SRAM memory card, disk or RAM by doing the following.

### To delete a Procedure:

1. Press TESTS.
2. Select **Save/Delete Procedure** from the **CUSTOMIZE TEST PROCEDURE** list (or **Proc Mngr** from the **Test Function** field).
3. Position the cursor to the **Select Procedure Location** (or **Location**) field and select it.
4. From the **Choices** menu, select the desired location.
5. Position the cursor to the **Enter Procedure Filename** (or **Procedure**) field and select it.
6. From the **Choices** menu, select the name of the procedure you wish to delete.
7. Press k2 (**Del Proc**) (or position the cursor to the **Action** field and select **Delete Procedure**).
8. Press **Yes** if you wish to continue.



## Securing a Procedure

After you have set up your test software with a testing order, channel information, test parameters, and pass/fail limits, you may wish to secure it. This operation will prevent the viewing and changing of those functions. You can select the items you wish to secure or un-secure. An IBASIC ROM program is stored in the Test Set's firmware to do this.

You can secure the procedure that is supplied with the test software. It is shipped un-secured.

After you make a procedure, you can secure it.

### To secure a Procedure:

1. Press TESTS.
2. Position the cursor to the **Select Procedure Location** (or **Location**) field and select it.
3. From the **Choices** menu, select **ROM**.
4. Position the cursor to the **Select Procedure Filename** (or **Procedure**) field and select it.
5. From the **Choices** menu, select **IB\_UTIL** (or **SECURE\_IT**).
6. Press k1 (**Run Test**).
7. Select the location of the procedure you want to secure: k1 memory (**Card**) or k2 (**RAM**).

---

### NOTE:

RAM refers to the RAM Disk memory within the test set. Before selecting RAM, you must **initialize the RAM as a disk**. See "**Initializing RAM Disks**" on page 275.

8. Proceed with the on-line instructions. You may wish to secure only one of the items, such as pass/fail limits.
9. When you are prompted to enter the **pass number**, enter any sequence of numerals 0 through 9 using the DATA keypad. Enter 9 digits or less.

**To un-secure a procedure:**

To un-secure a procedure, you must know the **pass number**.

1. Press TESTS.
2. Position the cursor to the **Select Procedure Location** (or **Location**) field and select it.
3. From the **Choices** menu, select **ROM**.
4. Position the cursor to the **Select Procedure Filename** (or **Procedure**) field and select it.
5. From the **Choices** menu, select **IB\_UTIL** (or **SECURE\_IT**).
6. Press k1 (**Run Test**).
7. Select the location of the procedure you want to un-secure: k1 memory (**Card**) or k2 (**RAM**).
8. Enter the name of the procedure you wish to un-secure.
9. If the procedure has any item secured, you will be asked for the **pass number**.
10. Proceed with the on-line instructions. Select the items you wish to un-secure.
11. When you are prompted, enter the **pass number** using the DATA keypad.

---

## RAM Disk

RAM disk is a section of internal memory that acts much like a flexible disk. Programs can be stored, re-stored, erased, and retrieved.

The RAM disk is partitioned into four separate volumes; 0-3. Each volume is treated as a separate disk. You can also specify the size of each disk in 256-byte increments.

The four RAM disk volumes are designated **:MEMORY,0,0** to **:MEMORY,0,3**. For example, to catalogue the contents of RAM disk volume '0' from the **IBASIC Cntrl** screen, enter

```
CAT  ":MEMORY,0,0"
```

Volume 0's contents can be viewed.

---

**RAM DISK ERASURE** Any existing programs or formatting on RAM is erased if you use the RAM\_MNG or COPY\_PL ROM programs, or the SERVICE screen's RAM Initialize function. Therefore, you should only use RAM disks for short-term storage of files.

---

## Initializing RAM Disks

Each RAM disk volume must be initialized before it can be used.

---

**NOTE:** If you are using a RAM disk to store a test procedure, you must initialize the RAM disk volume 0. When the software saves a procedure to the Test Set's RAM, it automatically stores **the procedure into the memory location volume 0. This is not changeable.**

---

**To initialize RAM disk Volume 0:**

Volume 0 can be initialized using the **RAM\_MNG** procedure stored on the internal ROM's **IB\_UTIL** menu.

1. Press the TESTS key.
2. Position the cursor to the **Select Procedure Location** field and select it.
3. From the list in the **Choices:** menu, select **ROM**.
4. Position the cursor to the **Select Procedure Filename** field and select it.
5. From the list in the Choices menu, select **RAM\_MNG**.  
**RAM\_MNG** is the RAM manager program.
6. Press the k1 (**Run Test**) key.  
The program will begin execution.
7. Read the precautions provided on the Test Set's screen and then press the k1 (**Yes**) key to continue.
8. Press the k3 (**Int RAM**) key.  
This selects the Test Set's internal RAM as the location to be initialized.
9. Enter the number of records you wish to initialize using the data key pad and then press the ENTER key.  
50 records should be sufficient for saving a procedure.
10. Press the k1 (**Yes**) key to verify the number of records was entered correctly.  
The internal RAM :MEMORY,0,0 is initialized.

**To initialize RAM volumes 1,2, or 3:**

Volumes 1, 2, and 3 must be initialized from the **IBASIC Cntrl** screen.

1. Press the TESTS key.
2. Select **IBASIC Cntrl** from the **SET UP TEST SET** list (or the Test Function field).
3. Position the cursor to the data entry field and select it.
4. Using the list of characters from the **Choices:** menu, enter the following command:

```
INITIALIZE ":MEMORY,0,<volume number 1-3>",<volume size>
```

or

```
INITIALIZE ":MEMORY,0,1",50
```

The optional 'volume size' in the command lets you specify the memory area set aside for each disk in 256-byte blocks.

---

## **Saving Tests Results**

See "[Data Collection \(Saving and Retrieving Test Results\)](#)" on page 232.

## Serial Port

This 6-pin, RJ-11 serial port is used to input and output serial data. Serial data is used for entering programs, printing, and for sending test results to a connected controller, disk drive, or terminal.

### Operating Considerations

The serial communications settings are defined on the I/O CONFIGURE screen. Ground is used with both IBASIC and all other serial connections. Transmit B and Receive B are exclusively used with IBASIC programs. Transmit and Receive are used with all other serial connections (see [figure 16](#)).

The IBASIC Controller sends data to and receives data from the serial ports using address **9** for the primary port, and address **10** for Port B.

Use an RJ-11/25-pin RS-232 adapter (HP P/N 98642-66508) and RJ-11 cable (HP P/N 98642-66505) to connect the HP 8920A,B,D to a serial printer or terminal/computer.

**RJ-11 CONNECTORS** RJ-11 cables and adapters can be wired several ways. If you buy a cable or adapter other than the HP parts listed, verify the connections for the pins indicated in the following table before connecting cables to the instruments.

The following table lists connections for Transmit, Receive, and Ground pins (address 9).

**Table 13** Connections for Transmit, Receive, and Ground Pins

HP 8920A/D RJ-11 Serial Port		Terminal/PC 25-Pin RS-232		Terminal/PC 9-Pin RS-232	
Pin 2 (RX)	to	pin 2 (TX)	or	pin 3 (TX)	
Pin 5 (TX)	to	pin 3 (RX)	or	pin 2 (RX)	
Pin 4 (GND)	to	pin 7 (GND)	or	pin 5 (GND)	

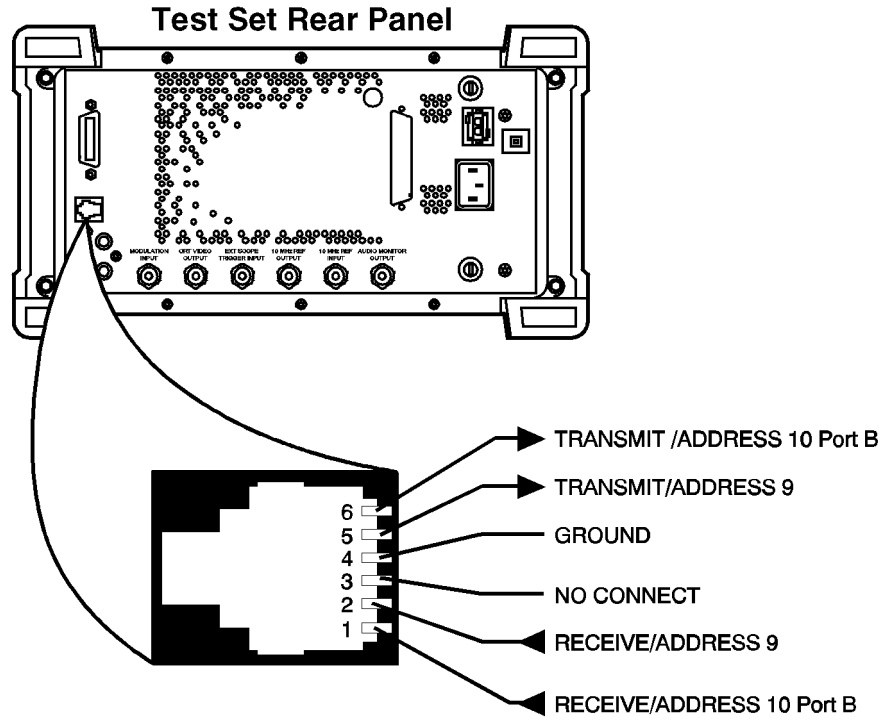

Figure 16 Test Set RJ-11 Serial Port Connections



---

## Test Execution Conditions

In some situations, you may wish to change the way the software works when a test result is obtained. **Test Execution Conditions** allow you to do this.

**Test Execution Conditions** are accessed from the **SET UP TEST SET** list on the TESTS (Main Menu) screen. Press TESTS, then select **Execution Cond** to display them. (They are displayed directly on the main TESTS screen in firmware below revision A.14.00).

**Test Execution Conditions** are not retained after a power-down/power-up cycle.

The following **Test Execution Conditions** can be set as needed:

### Output Results To: (Output Destination)

You can select either: **Crt** or **Printer** Default:**Crt**

You can specify where test results are to be placed. If you select **Crt**, results will be displayed on the test set's CRT. If you select **Printer**, test results will be sent to the CRT and to a printer. You must connect and configure a printer if you select **Printer**. See "[Printing](#)" on page 257.

### Output Results For: (Output Results)

You can select either: **All** or **Failures** Default:**All**

You can specify if you want only the failed results to be displayed or printed. This will be useful if you generally do not print test results, and want to ensure that failed results are displayed or printed.

### Output Heading

You can use this field to enter a heading that will be printed or displayed.

Select the **Output Heading** field. Use the knob to choose and enter the characters that you want to appear in the heading.

Choose **Done** when you are finished.

### **If Unit-Under-Test Fails (If UUT Fails)**

You can select either: **Continue** or **Stop** Default:**Continue**

If you set this to **Stop**, and a pass/fail result is **F**, the program will stop.

### **Test Procedure Run Mode (Run Mode)**

You can select either: **Continuous** or **Single Step** Default:**Continuous**

You can make tests pause at certain times. If you set this to **Single Step**, the program will pause after a comparison is made between a test determination and the expected result. For example, tests will pause after the program compares the results to a specification. You can continue from the paused state by pressing k2 (**Continue**).

### **Autostart Test Procedure on Power-Up**

You can select either: **On** or **Off** Default: **Off**

You can set up the test set so that if the procedure was previously loaded, the procedure will be immediately executed when the test set is powered on.

---

## USER Keys

When you are using the test set, you will see the following USER keys assigned appear at times in the top right corner of the display. These keys are assigned to the hard keys k1 through k5. In many cases, these keys can be used as “shortcuts” instead of positioning the cursor and selecting. USER keys are sometimes referred to as softkeys.

**Clr Scr** clears the test set’s CRT display. **Continue** continues the program after it has been paused.

**Delet Stp** is used to the edit items in a test sequence. When you press this key, the test in the displayed sequence that has its **Step #** highlighted (inverse video) will be deleted. The tests that follow in the sequence will be scrolled up by one step.

**Del Proc** is used to delete the selected procedure. When you press this key, you will be prompted to verify the command by pressing Yes.

Press **Done** when you want to exit a test or have completed a task. The program will continue if there is a next test in the sequence or if there are additional program steps in the test being run.

**Help** provides information on how to use the current TEST screen.

**Init Card** is used to initialize a memory card. Before you press this key, verify that the card is inserted correctly and not in the write-protected position.

**Insrt Stp** is used to enter items into a test sequence. When you press this key, the test in the displayed sequence that has its **Step #** highlighted (inverse video) will be copied into a new sequence location, immediately after the highlighted one. The tests that follow in the sequence will be scrolled down by one step. This key does nothing if there are no items in the sequence. Choose a test before using this key to insert another.

**Main Menu** is used to return to the main TESTS screen. The same result is achieved by pressing TESTS.

**Page Up**\Page Down are used to quickly display items in the list when some of the items won’t fit on the screen.

**Run** starts an IBASIC program that has been loaded into the test set’s memory.

**Run Test** loads and runs the program that is called from the procedure that has been entered into the TESTS screen **Select Procedure Filename:** entry. If the program is already loaded into the test set's memory, it will be started.

**Save Proc** is used to save the specified procedure.

**Sngl Step** steps the IBASIC program one line at a time. This is different from **Continuous/Single Step** run mode. See "**Test Execution Conditions**" on page 281.

**Stop Test** pauses the test software.

**Take It** causes the program to accept the setting of an adjustment, and proceed with the program. The test, determining if the adjustment is within limits, is ceased.

**Yes\No** are pressed when answering questions displayed on the test set's CRT display.

---

## Problem Solving

This chapter contains problem modules which alphabetically list the location of the problem with a brief symptom (for example, test set Doesn't Power Up). Each problem module describes possible causes and corrections. If a problem persists, call the HP Factory Hotline from anywhere in the USA (1-800-922-8920, 8:30 am - 5:00 pm Pacific time; in the USA and Canada only). w

---

**NOTE:** If the HP 8920A,D displays an error that states “One or more self-tests failed”, you have a hardware problem. In this case, refer to the HP 8920A *Assembly Level Repair* manual.

If the problem is related to HP 8920A,D operation, access the MESSAGE screen to see any messages that have occurred since the instrument was turned on. To do this, press the SHIFT then RX.

The *HP 8920A User's Guide* contains an “Error Messages” section to help identify errors.

---

---

## Data-Collection Function Does Not Work

- Check that you have **DATA C** entered in the **External Devices** (or **Edit Cnfg**) menu.

1. Press **TESTS**.
2. Select the **External Devices** screen, from the **SET UP TEST SET** list (or **Edit Cnfg** from the **Test Function** field).
3. Position the cursor to the **Calling Name** field, push the knob and enter:

**DATA C.**

- Check the **Model** field, it should be kept empty since it is not used.

- Check the **Addr** (address) field to make sure the correct address is entered for where the data is to be stored.

1. If data is to be stored on an SRAM memory card, enter “1” into the **Addr** field.
2. If data is to be stored on an external computer through the test set’s RS-232 serial port (if available), enter “9” into the **Addr** field.
3. If data is to be stored on an external disk drive over HP-IB, enter an address of “700” or greater into the **Addr** field.

- Check the **Options** field to make sure it is correctly set up:

1. **For an external disk drive (LIF format) or an SRAM memory card:**

- a. Enter **ASCII** for saving data as an ASCII file.
- b. Enter **BDAT** for saving data as a Binary-Data file.
- c. As an option, you may enter **REC=xxx**, where “xxx” is the number of records for each file. *(The software defaults to 80 records. However, if too small a record size is used, you’ll get an “End of file error” when the test is run.)*

2. **For a DOS disk drive, you may keep the Options field empty, or you may enter any of the following key words:**

- a. Enter **ASCII** for saving data as an ASCII file.
- b. Enter **BDAT** for saving data as a Binary-Data file.
- c. Enter **REC=xxx** for the file’s record size, where “xxx” is the number of records for each file. *(The software defaults to 80 records. However, DOS systems automatically change record size if it’s too small.)*
- d. Enter a **(dot extension)** of 3 characters or less for the file name. For example, all model ABCD radio’s tested may be organized to have a “.ABC” file extension.

- Check the test set to make sure it's in the controller mode *if you are using an external disk drive*.
- 1. Access the I/O CONFIGURE screen from the **More** field in the **To Screen** menu.
- 2. Position the cursor to the **Mode** field and select **Control**.

---

**NOTE:** When the test operator is prompted to enter a file name where data is to be stored, the protocol for the mass-storage device being used must be followed.

Hierarchical directory paths are not allowed, and all files are created with "FORMAT ON".

Also, when initializing a disk, use the following format ("7xx" is the disk address, "y" is the device selector):

**DOS disk: INITIALIZE "DOS:CS80,7xx,y"**

**LIF disk: INITIALIZE ":,7xx,y"**

---



---

## Establishing a Trunked Transmit or Receive Channel

- Check that the General Parameters have been set correctly. (One or more of the General Parameters may have been incorrectly set, or incorrect information may have been entered on the **System Information Screen** at the start of the procedure).
- Check the frequencies for trunked system channels. Trunked system channels *must* be entered in the range of channels 1 to 25 in the **Channel Information** (or Edit Frequencies) screen. (Only conventional channel information should be entered for channels 26 to 50.)
- Check the setting for parameter *RT trunked invert* for the radio under test.
- Check the value for parameter *RT trunked signaling high speed deviation* for the radio under test.
- Check the value for parameter *RT trunked signaling subaudible deviation* for the radio under test.
- Make sure the radio has been properly programmed.
- Make sure the radio is set to the correct site ID or system number for the channel you entered.
- The control channel cannot be the same as the working channel.
- If NC is always displayed on the radio, re-check the control channel settings.
- Make sure the test set is connected to the radio properly.

## Memory Space Problems

The HP 11807A,E program may use a substantial amount of the Test Set RAM space. If you see a message that indicates a memory problem, check the memory space that has been used. To determine the memory space used:

1. Load the program, if it is not already loaded, by pressing USER (**Run Test**) and waiting for the program display to appear.
2. Press SHIFT CANCEL to stop the program.
3. Press DUPLEX to exit the TESTS screen.
4. Press SHIFT SAVE.
5. Read the number in front of **free memory**.

If this number is 0%, you do not have sufficient memory space available to load and run the program. You need to delete some or all of the SAVE\_RECALL registers, and re-load the program.

If this number is a few percent or less, you may get an error message after saving additional set-ups to SAVE registers. If a memory error occurs after saving additional set-ups, you need to delete some or all of the SAVE\_RECALL registers.

**To Delete  
SAVE\_RECALL  
Registers:**

1. Press DUPLEX.
2. Press RECALL.
3. Position the cursor to the number of the recall register you wish to clear, or next to **CLR ALL** if you wish to clear all of the recall registers.
4. Press ON/OFF to clear register.
5. Press the ON/OFF button again to answer **YES**.

**To Re-Load the  
Program:**

*This program will clear any programs currently saved in RAM disk.*

*Refer to chapter 6 of the HP 8920A User's Guide.*

1. Press TESTS.
2. Position the cursor to the **Select Procedure Location** (or **Location**) field and select it.
3. From the **Choices** menu, select **ROM**.
4. Position the cursor to the **Select Procedure Filename** (or **Procedure**) field and select it.
5. From the **Choices** menu, select **IB\_UTIL** (or **Copy\_PL**).
6. Press k1 (**Run Test**).
7. Press k5 (**CLEAR RAM**).
8. Press TESTS, and re-load and run the Test Procedure you want.

---

## Printing Problems

- Check that the printer is turned on.
- Check that the HP-IB, parallel, or serial cable from the test set to the printer is connected.

**If have firmware below revision A.14.00 OR you are using software with Revision A.xx.xx**

1. Press TESTS.
2. Check that **Printer** was selected as the **Output Destination** in the **Test Execution Conditions**.
3. Check that the test set is correctly configured for HP-IB, parallel, or serial printing:

**For a HP-IB printer:**

- Check that the printer's **Calling Name** is "PRINTER" and its address is correctly set up in the **External Devices** (or **Edit Cnfg**) screen.
- Check that the I/O CONFIGURE screen has been set up correctly:
  - a. Mode=Control
  - b. Print To=HP-IB
  - c. Print Adrs=address of your printer

**For a parallel printer:**

- Check that the printer's **Calling Name** is **PRINTER** and its address is set to **15** in the **External Devices** (or **Edit Cnfg**) screen.

**For a serial printer:**

- Check that the printer's **Calling Name** is **PRINTER** and its address is set to **9** in the **External Devices** (or **Edit Cnfg**) screen.
- Check that the I/O CONFIGURE screen has been set up correctly for the printer's baud rate, parity, and so forth.

Refer to the test set's *User's Guide* for details about configuring the printer.

**If you have an HP 8920B or HP 8920A,D with firmware above revision A.14.00  
AND you are using software with Revision B.xx.xx**

1. Press TESTS.
2. Select **Printer Setup** from the **SET UP TEST SET** list.
3. Check that **Printer** was selected in the **Output Results To:**.
4. Check that the test set is correctly configured for HP-IB or serial printing:
  - a. Select **Model** and choose the most compatible printer model from the **Choices** menu.
  - b. Select **Printer Port** and choose which printer port you are using.
  - c. If the HP-IB port was selected, check that the correct **Printer Adrs** was entered.
  - d. If the Serial port was selected, check that the I/O CONFIGURE screen has been set up correctly for the printer's baud rate, parity, and so forth.

Refer to the test set's *User's Guide* for details about configuring the printer.

---

## Program was Incorrectly Loaded

If an error message such as “Structures improperly matched” or “improper context terminator” appears, the program is loaded incorrectly. This may have been caused by:

- Pressing CANCEL or SHIFT CANCEL keys, or removing the memory card, while the program was loading. To correct this problem, clear the HP 8920A,D RAM (see below for instructions), or load another program and then re-load the HP 11807A program.

---

### **NOTE:**

It takes up to 2 minutes to load an HP 11807A program when **Run Test** is first pressed; thereafter, it take only a few seconds to run. An asterisk ([asterisk]) is displayed in the upper right corner of the screen while the program is loading, and anytime a test is running.

To clear RAM in the HP 8920A,D: (This procedure will clear any programs currently saved in RAM disk. Refer to chapter 6 of the *HP 8920A User's Guide*.)

1. Press TESTS.
2. Position the cursor to the **Select Procedure Location** (or **Location**) field and select it.
3. From the **Choices** menu, select **ROM** .
4. Position the cursor to the **Select Procedure Filename** (or **Procedure**) field and select it.
5. From the **Choices** menu, select **IB\_UTIL** (or **Copy\_PL**) .
6. Press k1 (**Run test**).
7. Press k5 (**CLEAR RAM**) .
8. Press TESTS, and re-load and run the Test Procedure you want.

- Your HP 8920A,D may not have the required RAM expansion (option 005). To see if you do or do not have the RAM expansion -
  1. Press TESTS.
  2. Position the cursor to the **Select Procedure Location** (or **Location**) field and select it.
  3. From the **Choices** menu, select **ROM**.
  4. Position the cursor to the **Select Procedure Filename** (or **Procedure**) field and select it.
  5. From the **Choices** menu, select **LIST\_OPTS**.
  6. Press k1 (**Run test**).
  7. If the screen displays **OPTIONAL RAM**, your HP 8920A,D has enough RAM memory. If **OPTIONAL RAM** is not displayed, refer to "[Ordering Upgrades](#)" on [page 63](#) of [chapter 3](#), "[Product Description](#)".

## Radio Drastically Fails One or More Tests

- Make sure the radio is turned on.
- If using a programmable power supply, verify that the power supply is turned on, and that it is configured correctly in the **External Devices** (or Edit Cnfg) screen.
- Verify that your radio's power supply is not current-limiting while testing the radio.
- Verify all connections from the radio to the HP 8920A,D. See [chapter 4, "Making Connections"](#).
- Verify that the radio's programmed channels correspond to the frequencies entered in the Channel Information (or Edit Frequencies) screen.
- Verify that the pass/fail limit and parameter values for each test are correctly entered. Refer to [chapter 7, "Test, Parameter, and Pass/Fail Limit \(Specification\) Descriptions"](#).
- Verify that the test set is connected to the radio properly. See [chapter 4, "Making Connections"](#).
- If failure occurs during TX testing, make sure the radio did not timeout during the test. You may want to set parameter *TX de- key between TX tests* to **1=yes**, which unkeys and keys the radio for each TX test.

If your radio still doesn't respond as expected, you can use a conventional channel to verify the radio's basic receive and transmit functions.



### To Check Basic Transmitter Operation

1. Press PRESET on the HP 8920A,D.
2. Set your radio to transmit on a conventional channel.
3. Connect your radio's Antenna Port to the HP 8920A,D's RF IN/OUT connector.
4. Press the HP 8920A,D's TX key to access the TX TEST screen.
5. The default (and desired setting) for the **Tune Mode** field is **Auto**. If **Manual** is underlined, position the cursor in front of this field and press the knob to underline **Auto**.
6. Manually key your radio's microphone for at least 5 seconds.

The **TX Frequency** and **TX Power** for that channel should be displayed while the transmitter is keyed. If these measurements do not indicate as expected, your radio was improperly programmed (incorrect channel frequency), or it is not working correctly.

### To Check Basic Receiver Operation

1. Press PRESET on the HP 8920A,D.
2. Press the RX TEST key.
3. Set your radio to receive on a conventional channel.
4. Connect your radio's Antenna Port to the HP 8920A,D's RF IN/OUT connector.
5. Turn your radio's volume up to about 3/4 of maximum.
6. Enter the conventional channel's *Receive Frequency* into the **RF Gen Freq** field.<sup>1</sup>

You should now hear a 1 kHz tone coming from your radio's speaker. If no tone is heard, your radio was improperly programmed (the generated frequency does not match the receive frequency), or it is not working correctly.

<sup>1</sup> The deviation and rate are automatically set to 3 kHz and 1 kHz (respectively) when PRESET was pushed. Change these settings for your radio if necessary.

## Radio Fails CTCSS/CDCSS Tests

- Check parameter *RX conv CT/CDCSS deviation*. This parameter sets the amount of signaling deviation for the CTCSS tone or CDCSS code word which is input to the receiver's antenna.
- Verify that the correct information has been entered for the General (GN) Parameters and the **System Information Screen** (if used).
- Verify that the radio is set to the correct group or system number using CTCSS or CDCSS squelch.
- Verify that the radio is programmed correctly.
- Check the **Channel Information** (or **Edit Frequencies**) screen to see if the CTCSS frequency or tone code, or CDCSS code word is set up in the RX and TX channel information column. Refer to "**Specifying Channel Information**" on page 90 of [chapter 5](#).

---

## Radio Volume Can't Be Set When the Meter is Displayed

- Check that the radio is correctly connected to the HP 8920A,D. Refer to the *Radio Connections* drawing in [chapter 4, "Making Connections"](#).
- Check that the meter needle on the HP 8920A,D meter screen moves when you turn the radio's volume knob. If the meter needle doesn't move make sure the radio is powered on.
- When testing a conventional channel, check to see that any external squelch controls on the radio are set as directed in the test.
- If the meter needle moves but cannot be set high enough, check to see if the parameters for setting radio volume are correctly set up. Incorrect settings for any one of these parameters will affect how the test runs.
  1. Parameter *RX audio load impedance* is used by the software whenever radio volume or squelch control is adjusted during testing.
  2. Parameter *RX audio maximum power* sets the full-scale volume level of the meter displayed on the HP 8920A,D.
  3. Parameter *RX tolerance for setting volume* sets the tolerance window displayed on the meter screen.
  4. The trunked receive channel was not established. Press the **Not Set** USER key and try to establish the channel again when prompted.

## Test Procedure Doesn't Run on Your HP 8920A,D

- Verify that the HP 11807A,E software IBASIC program has been loaded. Test Procedure files do not contain the IBASIC program needed to run the tests. If you stored a procedure to SRAM memory card, that card will not contain a copy of the IBASIC program code needed to run the procedure.

Load your procedure from the SRAM card, then insert the original pre-programmed HP 11807A,E memory card into the memory card slot and press k1 (**Run Test**) to start testing. After running your procedure, the program code remains loaded in the HP 8920A,D until another program is loaded.

- Verify that the memory card is correctly inserted into the HP 8920A,D. Remove the card and insert it correctly.
- Verify that the procedure file is loaded into the HP 8920A,D. Refer to "[Selecting a Test Procedure](#)" on page 82 in [chapter 5](#).
- Try again, and press k1 (**Run Test**) after loading a procedure.
- Verify that your HP 8920A,D does have all of the required equipment. Refer to "[Additional Services Available](#)" on page 67 of [chapter 3](#).

If you still have a problem, check the MESSAGE screen to view any recorded errors.

If you see the error message "Structures improperly matched" or "Improper context terminator", the HP 11807A,E program was incorrectly loaded into the HP 8920A,D. In this case, refer to the instructions for *Program was Incorrectly Loaded*.

---

## Test Set Doesn't Power Up

Check the AC or DC power connection and the setting of the AC/DC switch on the rear panel. See the test set's *User's Guide*.

## Transmitter Isn't Keying

### Using Manual or Automatic Keying

- Verify that the trunked radio information in the **System Information Screen** and/or trunked radio parameters are correct for the channel being tested.

If the correct information is not received from your radio when it is first keyed, the HP 8920A,D will not establish the trunked channel, and your radio will stop trying to transmit. Refer to the test's description in [chapter 7](#), and verify that you have entered the correct parameter information required for trunked radios.

- If you selected **Conventional** at the start of the test when prompted, but the radio is set to a trunked channel or system this error will occur. Either select **Trunked** at the start of the test, or select the proper conventional channel on your radio and try again.
- Check to see if your radio has a transmitter time-out function that interrupts transmission. Parameter *TX dekey between TX tests* [0=no 1=yes], causes the transmitter to dekey between transmitter tests, re-setting the timeout counter each time.

### Using Manual Keying

If you want manually key the transmitter when prompted by the software, using the microphone's key (not using the HP 8920A,D's MIC/ACC connector):

- Verify that parameter *TX user/system key UUT* [0=user 1=sys] is set to **0 = user** to have the software prompt you when to manually key the microphone.

## Using Automatic Keying

If your radio is connected to the HP 8920A,D's MIC/ACC connector to automatically key and de-key the transmitter:

- Verify that parameter *TX user/system key UUT [0=user 1=sys]* is set to **1 = sys** to have the software automatically key the microphone during tests.
- Verify that the Key Out 1 and Key Out 2 connections of the MIC/ACC connector are properly connected to your radio. These lines provide a SPST switch path that is used in place of your radio's microphone key lines.

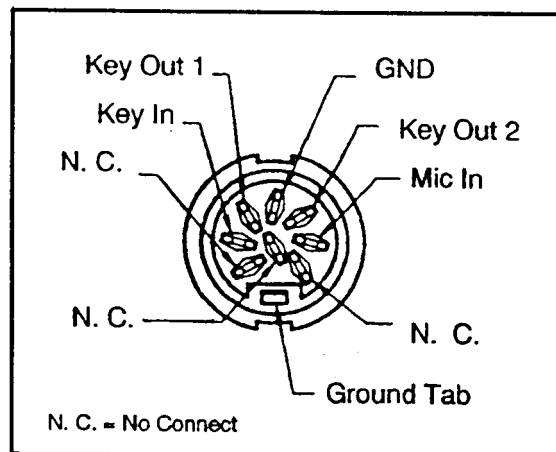





---

## Glossary

**CANCEL** A key used to pause (stop) the IBASIC program running in the test set.

**card** Refers to the memory card containing the procedures for testing the unit-under-test.

**Choices** Refers to a field in the lower right of the screen that displays several possible functions for selection.

**Continue** Proceed with the IBASIC software program if it has been stopped (paused).

**CS** Carrier Squelch

**CTCSS** Continuous Tone Controlled Squelch System

**cursor** Refers to the brightened region of the screen used to indicate the field/function currently being accessed.

**Del Step** A function to delete a step in the procedure.

**Disp Loc** A menu function which presents an assembly diagram that displays location of the adjustable component.

**ESD** ElectroStatic Discharge - A transfer of electric charge from one place to another. Devices can be damaged by the energy transferred during the discharge.

**field** An area on the CRT with an inverse video display (**example**) where entries can be made.

**function** Refers to a particular field, feature, or operation of the test set.

**GN** Abbreviation for General. GN appears in some titles in the software and indicates that it relates to the general system, as opposed to a transmitter (TX) or receiver (RX).

**Help** A feature providing specific information about how to use the current screen in the TESTS environment. This feature is accessed by pressing k4 (**Help**) from any TEST screen. Note: only available in the HP 8920B and HP 8920A,D firmware above revision A.14.00.

**HELP** A feature providing additional test set information accessed by pressing SHIFT, then TX (HELP) keys. Help topics are listed in alphabetical order.

**highlight** Refers to the brightened region (cursor) of the screen used to indicate the field/function currently being accessed.

**HPF** High Pass Filter. A filter that increasingly passes signals as their frequency increases towards, and then is greater than, a certain cutoff frequency. In the Test Set, audio high pass filters are used to reduce the level of low frequency signals during certain measurements.

**IBASIC** Instrument BASIC is the computer language (code or software) used by the test set's built-in controller. The IBASIC software is downloaded from the OTP CARD into the test set's RAM. This software is then used to control the test set during autotesting the unit-under-test.

---

## Glossary

**initialize** A card or disk must be formatted prior to storing data. This may be done by pressing k3 (**Init Card**) on the TESTS (**Save/Delete Procedure**) screen. The default for PCMCIA cards (HP 11807E) is DOS format, and for Epson Cards (HP 11807A,B) is LIF format. See "**Memory Cards**" on page 246 for information on changing these default settings.

**key (USER keys)** Keys refer to any of the push buttons on the front panel of the test set. The USER keys are a specific grouping of keys labeled k1 to k5 which perform the associated numbered function in the action field located in the upper right of the screen. The USER keys are user programmable.

**knob** The large tuning dial for cursor control located in the center of the test set front panel. This knob is rotated to position the cursor on the screen and then pressed to select the particular field or function.

**library** A collection of the names of all of the parameters, pass/fail limits, and tests in the test software. The test software and the test set's firmware use the library, test software program code file, and a procedure to run a customized application program. A library is stored as a file on a memory card or other mass storage with its associated procedure files.

**Location** Where to retrieve or save a particular testing procedure, for example, to a disk, card, RAM, or PC.

**LPF** Low Pass Filter. A filter that increasingly rejects signals as their frequency increases towards, and then is greater than, a certain cutoff frequency. In the Test Set, audio low pass filters are used

to reduce the level of high frequency signals during certain measurements.

**measurement** A series of calculations on data measured by the test set. These calculations provide a value to be compared against pass/fail limit values that verify the performance of the unit-under-test.

**Main Menu** The screen accessed by pressing the TESTS key, or k5 (**Main Menu**). It is used to customize and execute (run) automated testing.

Also referred to as the "TESTS" screen.

**menu** The test set's screen displays various tasks to be selected with the cursor control knob or the USER keys ; this display is the menu.

**message** The upper portion of the test set's screen is reserved for messages and prompts. Messages give an indication of the status of the test set, for example, **System initialization**.

**OTP** One Time Programmable (OTP) refers to a CARD on which code or data may only be stored once; similar to ROM. The HP 11807A/E software is shipped on an OTP memory card.

**parameters** Entries you make for calibration data, phone characteristics, or test customization. They give you flexibility in the way you use the software. Default values for parameters are present in the software.

---

## Glossary

**pass/fail limits** Pass/fail limits are the names of criteria verifying the performance of the unit-under-test. Usually, the associated measurement value must fall within the HI/LO limits of pass/fail values to verify performance of the unit-under-test. Default values in the test software have been derived from standard methods of measurement or from the unit-under-test requirements.

**pause** Using the CANCEL key pauses the running of IBASIC software in the test set and allows access to the keyboard functions. CONTINUE allows the software to proceed.

**peak+/- max** A detector in the test set that measures and computes the maximum of the absolute value of the positive and negative excursions of the measurement. For example, when an FM waveform with a +10 kHz and -9 kHz deviation is applied, 10 kHz will be displayed.

**PRESET** Sets the test set to its initial power-up state.

**procedure** A shortened label for test procedure. A procedure is a collection of channels, parameters, pass/fail limits, and testing order, saved in a file, that customizes the test software to a specific application. Procedures are made by editing existing channels, parameters, pass/fail limits, and testing order, and saving the resulting files to a memory card, disk or internal test set RAM.

**prompts** The upper portion of the test set (inverse video field) is reserved for prompts and messages. The prompt directs the user to take some action. Messages give an indication of the status of the test set.

**RAM** Random Access Memory - The memory in the test set that is used to store program code and data. The test set's RAM is battery-backed-up, retaining data and program codes when the power is turned off.

**ROM** Read Only Memory

**Run Test** Directs the test set to load the program from the current procedure and begin testing (may take up to two minutes).

**save** Save and store are used synonymously and refer to putting data or software on some memory device, such as, card or RAM.

**screen** Refers to the video display of the test set.

**select** To choose a particular field or function. Rotate the CURSOR CONTROL knob and position the highlighted cursor on the chosen field or function, then press the knob. An alternative method is to press the numbered USER key having the same number as displayed alongside the desired function.

---

## Glossary

**sequence** The method used in the Test Set to run one or more TESTs in a desired order. A sequence is entered using the TESTS (**Edit Sequence**) screen.

**SINAD** Signal plus Noise And Distortion divided by noise and distortion. A measurement result that determines the quality of an audio tone in the presence of noise and distortion. A 12 dB SINAD value is often used when measuring the receiver sensitivity.

**softkey** The name of the set of keys next to the CRT display that can be assigned to certain special actions or fields. The keys are also called USER keys.

**SRAM** Static Random Access Memory - A data storage device. SRAM memory cards can be used with the test set to save programs and test results.

**Step#** Orders the sequence of tests, e.g. Step #1 may be Test\_5, and Step #2 may be Test\_26 and so on.

**store** Store and save are used synonymously and refer to putting data or software on some memory device, such as card, RAM.

**tests** Tests are a collection of measurements (or a series of other tests) which verify a particular specification value or operation of the UUT. A sequence of tests are contained in a test procedure.

**TESTS screen** The screen accessed by pressing the TESTS key. It is used to customize and execute (run) all automated testing. Also referred to as the "Main Menu".

**USER keys** A group of keys located immediately to the right of the test set's screen that allow the user to more rapidly select certain functions without rotating and pressing the knob. These key assignments are displayed in the upper right portion of the test set's screen. The number on the left of the function corresponds to the number on the user key k1 to k5.

**values** The scalar quantities or numbers inserted in the inverse video fields of the pass/fail limits or parameters. Units of measure (dB, inches, volts, watts, etc.) are contained in the pass/fail limits and test parameters.

---

**Numerics**

OSPEC, [36, 59](#)  
1-800 help line, [67](#)

**A**

AA use GN value from, parameter 1 description, [207](#)  
AA use GN value from, [226](#)  
additional services available, [67](#)  
Adjustment, [36, 59](#)  
AdvanceLink, [236](#)  
ASCII file type, [232](#)  
Audible Tone, [36, 59](#)  
Audio Distortion, [201](#)  
Audio Power, [201](#)  
Autostart Test Procedure on Power-Up, [282](#)

**B**

Bantam 309  
Type Bantam 309, [32, 54](#)  
BDAT file type, [232](#)  
Beeps, [37, 59](#)  
BNC  
Type BNC, [32, 54](#)

**C**

CANCEL, 37, 59, 256, 305  
Card, 22, 24, 37, 44, 46, 59  
    how to insert, 81, 118  
CAT IBASIC command, 230  
CD Code, 226  
CDCSS SquelchInformation, 227  
Chan#, 223  
Changing the Order of Tests, 86  
channel information, 226  
    general description, 90, 223  
    saving, 223  
    securing, 273  
channel numbers, 223  
    specifying information, 90, 126  
Channel Operation, 201  
channels, test multiple, 152, 226  
Chk Chans, 224  
Choices, 25, 47, 222, 305  
choose, 222  
CLEAR RAM, 294  
Clr Scr, 283  
Combined, 24, 46  
Component Indicated, 36, 59  
configuration  
    for data collection, 232  
    for terminal or PC operation, 238  
configuring an IBM-compatible PC with  
    HP AdvanceLink, 236  
connecting  
    the radio, 81  
connecting a printer, 258  
connections  
    parallel printer, 259  
    RJ-11 connector, 258  
    serial printer, 258  
Continue, 283, 305  
Continue USER key, 256  
continuing a paused program, 256  
conventional channel numbers, 90, 126,  
    223  
Conventional Channels, 223  
conventions used, 222  
COPY IBASIC command, 230  
Copy\_PL, 294  
copying files, 230  
CTCSS, 305  
CTCSS SquelchInformation, 227

**CTCSS/CDCSStests**

    failed, 298  
Cursor, 24, 46  
cursor, 305  
Cursor Control Knob, 24, 46  
customizing testing, 84, 120

**D**

data collection  
    description, 232  
    doesn't work, 287  
    entering the configuration for, 232  
    example configuration, 233  
    memory card part numbers, 248  
    retrieving data, 234, 242, 250  
    saving to a memory card or disk, 232  
    to a PC, 236  
    to a PC, setting up, 238  
DB-25, 37, 59  
Del Proc, 283  
Delet Stp, 283, 305  
deleting a procedure, 272  
Designator of Component, 36, 59  
disk  
    initializing, 241  
    initializing a RAM disk, 275  
    retrieving data from, 242  
disk drive  
    External Disk Specification, 269  
disk formats, LIF and DOS, 232  
Disp Loc, 36, 59  
Done, 283  
DOS disk format, 232  
DOS file type, 232

**E**

Edit Configuration  
 data collection to a PC, 238  
 Edit Frequency, 90, 126  
 Edit Parameters, 36, 37, 59, 100, 136  
 Edit Sequence, 122  
 Edit Spec, 59, 254  
 Edit Specifications, 97, 133  
 enter, 222  
 ENTER key, 222  
 equipment  
 additional requirements, 63  
 included, 62  
 recommended, 63  
 Error Messages, 286  
 escape sequences, 262  
 rev B software with fw below A.14.00,  
 266  
 exiting a program, 244

**F**

Factory Hot Line, 67  
 Factory-Defined Procedures, 149  
 Chans, NB\_Chan, 149  
 Full, NB\_Full, 149  
 Manual, NB\_Manl, 149  
 Failed Spec, 37, 59  
 Failure, 36, 59  
 field, 305  
 selecting a, 222  
 file name  
 disk example, 242  
 file types, ASCII, BDAT, DOS, and HP-  
 UX, 232  
 files  
 copying, 230  
 flash  
 memory cards, 246  
 frequencies, 223  
 frequency  
 editing values, 90, 126  
 general description, 126  
 frequency table  
 general description, 223  
 saving, 223  
 front-panel control characters, 239

**G**

General (GN) Parameters, 151, 223  
 Getting Started  
 what's tested, needed, 19, 41  
 GN, 150, 305  
 GN choose radio type, parameter 2 de-  
 scription, 207  
 GN conv chan#, parameter 3 description,  
 207  
 GN conv RX CDCSS code, parameter 4  
 description, 207  
 GN conv RX CTCSSfreq (Hz), parameter  
 5 description, 207  
 GN conv RXsquelch, parameter 6 de-  
 scription, 207  
 GN conv TX CDCSS code, parameter 7  
 description, 207  
 GN conv TX CTCSSfreq (Hz), parameter  
 8 description, 207  
 GN conv TXsquelch, parameter 9 de-  
 scription, 207  
 GN Parametersdescription, 207  
 GN read logininformation, parameter 50  
 description, 213  
 GN trunked call type, parameter 10 de-  
 scription, 207  
 GN trunked callee ID, parameter 11 de-  
 scription, 208  
 GN trunked control chan#, parameter 12  
 description, 208  
 GN trunked data standard, parameter 14  
 description, 208  
 GN trunked data rate (bps), parameter  
 13description, 208  
 GN trunked group ID, parameter 15 de-  
 scription, 208  
 GN trunked logical ID, parameter 16 de-  
 scription, 208  
 GN trunked site ID, parameter 17 de-  
 scription, 208  
 GN trunked workingchan#, parameter 18  
 description, 208  
 Graticule, 36, 59

---

**H**

hardware configuration, 71  
hardware problems, 286  
Help, 283  
HP 11807A,E Software  
  description, 116  
HP-IB control annunciators, 245  
HP-IB printer, 260  
HP-IB printer connections, 258  
HP-UX file type, 232

**I**

IBASIC, 305  
  copying files, 230  
  initializing a disk, 241  
  retrieving data from a card, 235, 251  
  retrieving data from a disk, 242  
  TESTS screen, 84, 120  
IBASIC commands  
  entering from a terminal, 230  
If Unit-Under-Test Fails, 282  
If Unit-Under-Test-Fails, 106  
If UUT Fails, 282  
improper context terminator, 294  
Init Card, 283  
initializing, 306  
  RAM disk, 275  
initializing a disk, 241  
initializing an SRAM memory card, 249  
Insrt Stp, 283

**K**

Key Out 1, 73  
Key Out 2, 73  
Keying  
  Microphone, 302  
Knob, 37, 59



**L**

library, 306  
  definition, 102, 140  
  saving, 102, 140, 269  
LIF disk format, 232  
LIST\_OPTS, 295  
loading a procedure, 271  
loading software, 81, 116  
loading software upgrade, 116  
Location, 24, 46, 83, 118, 306  
login information  
  parameter, 213  
Lower Limit, 36, 59

**M**

Main Menu, 283, 306  
measurement, 306  
measurements, 148  
memory cards, 24, 38, 46, 60, 305  
  are used for, 246  
  determining whether it is OTP, flash, or  
    SRAM, 246  
  flash, 246  
  how they're powered, 246  
  initializing, 249  
  inserting, 246  
  OTP, 246  
  removing, 247  
  retrieving data from, 234, 250  
  saving data to, 232  
  software, 81, 116  
  SRAM, 246  
  SRAM battery part number, 248  
  Static Random Access Memory  
    (SRAM), 248  
  storage space needed, 249  
  write protect switch, 248  
memory space  
  determining the amount used, 290  
memory space problems, 290  
meter, 36, 59  
MIC/ACC Connections, 73  
Microphone keying, 302  
Multiple Channels, 152  
multiple channels, 152, 226

**N**

N  
  Type N, 32, 54  
No, 284  
Not Set, 299

## O

On UUT Failure, 144  
 order of tests  
   printing, 257  
   saving, 270  
 ordering upgrades, 63  
 OTP  
   memory cards, 246  
 OTP card, 306  
 Output Destination, 144, 281  
 Output Heading, 106, 144, 281  
 Output Results, 144, 281  
 Output Results For, 106, 281  
 Output Results To, 106, 281

## P

Page Down, 283  
 Page Up, 283  
 parallel printer connections, 259  
 Parameter, 36, 59  
 Parameter 1 Description  
   AA use GN valuefrom, 207  
 Parameter 10Description  
   GN trunked call type, 207  
 Parameter 11Description  
   GN trunked callee ID, 208  
 Parameter 12 Description  
   GNtrunked control chan#, 208  
 Parameter 13 Description  
   GN trunked date rate(bps), 208  
 Parameter 14 Descriptions  
   GN trunked data standard, 208  
 Parameter 15Description  
   GN trunked group ID, 208  
 Parameter 16Description  
   GN trunked logical ID, 208  
 Parameter 17Description GN trunked site  
   ID, 208  
 Parameter 18 Description  
   GN trunked workingchan#, 208  
 Parameter 19 Description RT external RF  
   pad andcable loss, 209  
 Parameter 20 Description RT full rated  
   systemdeviation, 209  
 Parameter 21 DescriptionRT highsupply  
   voltage, 209  
 Parameter 22 Description RT lowsupply-  
   voltage, 209  
 Parameter 23 DescriptionRT nominal-  
   supply voltage, 209  
 Parameter 25Description RTstandard RF  
   input level, 209  
 Parameter 26 Description RT trunkedin-  
   vert, 210  
 Parameter 27 Description RT trunked  
   signalingdeviation, high speed, 210  
 Parameter 28 Description RT trunked  
   signalingdeviation, subaudible, 210  
 Parameter 29 Description RX audio freq  
   responsestep frequency, 210  
 Parameter 2Description  
   GN choose radio type, 207  
 Parameter 3 Description  
   GN conv chan#, 207  
 Parameter 30 DescriptionRX audioload  
   impedance, 210  
 Parameter 31 DescriptionRX audiomaxi-  
   mum power, 210  
 Parameter 32Description RX convCT/  
   CDCSS deviation, 210  
 Parameter 33 Description RX conv sens  
   set andmeas, 210  
 Parameter 34 Description RX conv  
   squelch blockingstep frequency, 211  
 Parameter 35Description RXconv  
   squelch control, 211  
 Parameter 36 Description RX conv  
   squelch presetonly, 211  
 Parameter 37 DescriptionRX setradio  
   volume, 211  
 Parameter 38 Description RX tolerance  
   for settingvolume, 211  
 Parameter 39 Description TX audio distn  
   % fullrated system dev, 211  
 Parameter 40 Description TX audio freq  
   responsestart frequency, 211  
 Parameter 41 Description TX audio freq  
   responsestep frequency, 211  
 Parameter 42 Description TX audio fre-  
   quencyresponse stop frequency, 211  
 Parameter 43 Description TX conv CT/  
   CDCSScontrol, 211  
 Parameter 44 Description TX de-key be-  
   tween TXtests, 212  
 Parameter 45 Description TX mic sens  
   set andmeasure, 212  
 Parameter 46 Description TX modulation  
   limitingsweep step freq, 212  
 Parameter 47Description TXpower high/  
   low switch, 212  
 Parameter 48Description TXuser/system  
   key UUT, 212  
 Parameter 49Description XXsecure fre-  
   quency info, 212  
 Parameter 4Description  
   GN conv RX CDCSS code, 207  
 Parameter 5 Description  
   GNconv RX CTCSSfreq (Hz), 207  
 Parameter 50 Description GN read login-  
   information, 213  
 Parameter 6 Description

- GN conv RXsquelch, 207
- Parameter 7Description
  - GN conv TX CDCSS code, 207
- Parameter 8 Description
  - GNconv TX CTCSSfreq (Hz), 207
- Parameter 9 Description
  - GN conv TXsquelch, 207
- parameters, 306
  - default values, 206
  - descriptions, 206
  - editing values, 100, 136, 252
  - general description, 100, 136, 252
  - printing, 257
  - saving, 102, 140, 252, 270
  - securing, 273
- part numbers
  - memory card battery, 248
  - software memory cards, 62
  - SRAM Memory Cards, 248
- pass number, 273
- Pass/fail limit, 36
- pass/fail limit, 37
- Pass/fail limit 1 Description RX audio distn 17 dBbelow rated power, 214
- Pass/fail limit 10 Description RX conv hum and noisewith signaling, 215
- Pass/fail limit 11Description RX convsquelch blocking, 215
- Pass/fail limit 12 Description RX conv threshold sqSINAD @ opening, 215
- Pass/fail limit 13 Description RX convthreshold squelch sensitivity, 216
- Pass/fail limit 14 Description RX conv tight squelchsensitivity, 216
- Pass/fail limit 15 Description RX conv tight squelchSINAD @ opening, 216
- Pass/fail limit 16 Description RX conv variation ofsens delta freq, 216
- Pass/fail limit 17 Description RXhum and noise unsquelched, 216
- Pass/fail limit 18 Description RXstandby current drain, 216
- Pass/fail limit 19 Description RX trunked squelchopening level, 216
- Pass/fail limit 20 Description RX trunked squelchSINAD at opening, 216
- Pass/fail limit 21Description RXusable sensitivity, 217
- Pass/fail limit 22 Description RX usable sensitivitySINAD level, 217
- Pass/fail limit 23Description TX audiodistortion, 217
- Pass/fail limit 24 DescriptionTX audio response delta from 6dB/oct, 217
- Pass/fail limit 25 Description TXaudio freq response roll %, 217
- Pass/fail limit 26 Description TX audio response roll>2.5 kHz, 217
- Pass/fail limit 27 Description TXconv CT/CDCSS deviation, 217
- Pass/fail limit 28 Description TXconv CTCSS frequency error, 217
- Pass/fail limit 29 DescriptionTX currentdrain, 217
- Pass/fail limit 2Description RX audiodistortion, 214
- Pass/fail limit 30 Description TXdeviation if set and measure mic sens, 218
- Pass/fail limit 31 DescriptionTX FM hum andnoise, 218
- Pass/fail limit 32 DescriptionTX frequencyerror, 218
- Pass/fail limit 33 Description TXmicrophone sensitivity, 218
- Pass/fail limit 34Description TX modulation limiting, 218
- Pass/fail limit 35 DescriptionTX outputpower, 218
- Pass/fail limit 36 Description TX output power athigh supply, 219
- Pass/fail limit 37 DescriptionTX output power at high supply lowswitch, 219
- Pass/fail limit 38 Description TX output power at lows supply, 219
- Pass/fail limit 39 Description TXoutput power at low supply low switch, 219
- Pass/fail limit 3Description RX audio freq resp deltafrom 6 dB/oct, 214
- Pass/fail limit 4 Description RX audiofreq response roll, 214
- Pass/fail limit 40 Description TX output power lowswitch setting, 219
- Pass/fail limit 41 Description TX residual AM hum andnoise, 219
- Pass/fail limit 42Description TX trunked-deviation, low speed, 219
- Pass/fail limit 43 Description TX trunked-deviation, high speed, 219
- Pass/fail limit 5 Description RXaudio freq response roll >2.5kHz, 214
- Pass/fail limit 6 Description RX audiooutput @40% of full rated dev, 215
- Pass/fail limit 7 Description RX convCT/ CDCSS squelch opening level, 215
- Pass/fail limit 8 Description RX convCT/ CDCSS squelch SINAD at opening, 215
- Pass/fail limit 9 Description RX conv hum and noisesquelched, 215
- pass/fail limits, 307
  - default values, 214
  - descriptions, 214
  - editing values, 97, 133, 255
  - general description, 97, 133, 254
  - printing, 257
  - saving, 254, 270
  - securing, 273
- pause, 307
- pausing a test, 115, 256
- PC
  - collecting data to, 236
  - power supply connections, 71
- PRESET, 81, 118, 307
- Preset, 22, 37, 44, 59
- Prime?, 224
- print options
  - pitch, margins, paper size, typeface, 262, 266
- printer
  - HP-IB, 260
  - output heading, 281
  - problems, 292
  - serial, 260
- printers supported, 257
- printing, 257
  - problems, 292
  - test results, 281
  - test results using firmware above revision A.14.00, 261
  - test results using firmware below revision A.14.00, 266

- 
- TESTS Screens, 264, 268  
 using A.xx.xx revision software, 260
- problem solving, 285  
 printer problems, 292  
 test set doesn't power up, 301
- Procedure, 24, 46, 83, 118
- procedure, 148, 307  
 deleting, 272  
 general description, 102, 140, 269  
 loading into test set memory, 271  
 names, 269  
 saving, 102, 140, 269  
 securing, 273  
 un-securing, 274  
 what is saved, 269
- procedure doesn't run, 300
- Procedures, Factory-Defined, 149  
 Full, NB\_FULL, 149  
 Manual, NB\_Manl, 149
- Procedures, Factory-Defined  
 Chans, NB\_Chan, 149
- product description, 62
- program  
 exiting a program, 244  
 stored in test set memory, 247
- R**
- radio  
 connecting, 81
- radio connections, 71
- radiodastically fails, 296
- RAM, 307  
 clear, 294  
 disk, 275  
 initializing, 275
- RAM expansion, 295
- Read UUT, 200
- REC=  
 default entry, 233  
 entering record number, 233
- REC= to set record size, 233
- Receiver  
 Basic Test, 297
- retrieving data from a memory card, 234
- RF Level, 201
- RJ-11, 29, 37, 51, 59  
 Type RJ-11, 32, 54
- RJ-11 connectors, 279
- ROM, 307
- RS-232, 29, 32, 37, 51, 54, 59
- RT, 150
- RT external RF pad and cable loss, parameter 19 description, 209
- RT full rated system deviation, parameter 20 description, 209
- RT high supply voltage, parameter 21 description, 209
- RT low supply voltage, parameter 22 description, 209
- RT nominal supply voltage, parameter 23 description, 209
- RT signaling filter 1 opt, parameter 24 description, 209
- RT trunked invert, parameter 26 description, 210
- RT trunked signaling deviation, high speed, parameter 27 description, 210
- RT trunked signaling deviation, subaudible, parameter 28 description, 210
- RT standard RF input level, parameter 25 description, 209
- Run, 283
- Run Mode, 144, 282
- Run Test, 284, 307
- difference between Run and, 235, 251
- running tests, 75  
 overview, 79, 113
- RX, 150
- RX audio distn 17 dB below rated power, pass/fail limit 1 description, 214
- RX audio distortion, 192
- RX audio freq resp delta from 6 dB/oct, pass/fail limit 3 description, 214
- RX audio freq response roll >2.5kHz, pass/fail limit 5 description, 214
- RX audio freq response roll, pass/fail limit 4 description, 214
- RX audio freq response step frequency, parameter 29 description, 210
- RX audio load impedance, 299
- RX audio maximum power, 299
- RX audio output @40% of full rated dev, pass/fail limit 6 description, 215
- RX audio sensitivity, 192
- RX audiodistortion, pass/fail limit 2 description, 214
- RX audioload impedance, parameter 30 description, 210
- RX audiomaximum power, parameter 31 description, 210
- RX Chan Info, 226
- RX conv CT/CDCSS squelch opening level, pass/fail limit 7 description, 215
- RX conv CT/CDCSS squelch SINAD at opening, pass/fail limit 8 description, 215
- RX conv hum and noise squelched, pass/fail limit 9 description, 215
- RX conv hum and noise with signaling, pass/fail limit 10 description, 215
- RX conv sens set and meas, parameter 33 description, 210
- RX conv squelch blocking, 192
- RX conv squelch blocking step frequency, parameter 34 description, 211
- RX conv squelch preset only, parameter 36 description, 211
- RX conv threshold sq SINAD @ opening, pass/fail limit 12 description, 215
-

- 
- RX conv threshold squelch sensitivity, pass/fail limit 13 description, 216
  - RX conv tight squelch sensitivity, pass/fail limit 14 description, 216
  - RX conv tight squelch SINAD @ opening, pass/fail limit 15 description, 216
  - RX conv variation of sens delta freq, pass/fail limit 16 description, 216
  - RX conv CT/CDCSS deviation, parameter 32 description, 210
  - RX conv squelch blocking, pass/fail limit 11 description, 215
  - RX CT Tone, 226
  - RX frequency response, 192
  - RX hum and noise, 192
  - RX set radio volume, parameter 37 description, 211
  - RX squelch opening with signaling, 192
  - RX Squelch Type, 226
  - RX tolerance for setting volume, parameter 38 description, 211
  - RX trunked squelch opening level, pass/fail limit 19 description, 216
  - RX trunked squelch SINAD at opening, pass/fail limit 20 description, 216
  - RX usable sensitivity, 192
  - RX usable sensitivity SINAD level, pass/fail limit 22 description, 217
  - RX conv squelch control, parameter 35 description, 211
  - RX CT/CDCSS deviation, 298
  - RX hum and noise un-squelched, pass/fail limit 17 description, 216
  - RX stand-by current drain, pass/fail limit 18 description, 216
  - RX tolerance for setting volume, 299
  - RX usable sensitivity, pass/fail 21 limit description, 217
- S**
- save, 307
  - SAVE IBASIC command, 230
  - Save Proc, 284
  - saving
    - procedure, 102
    - test procedure, 102, 140
    - test results, 232
  - saving a procedure, 269
  - SECURE IT ROM program, 273
  - securing a procedure, 273
  - Securing Frequency Information, 229
  - select, 222, 307
  - self test failed, 286
  - sequence, 308
    - changing, 86
    - editing, 122
    - general description, 86, 122
    - saving, 102, 140
  - Serial Port, 279
  - serial port connections
    - figure, 280
  - serial printer, 260
  - serial printer connections, 258
  - Set-up Testing, 28, 30, 50, 52
  - SINAD, 201, 308
  - Sngl Step, 284
  - softkey, 308
  - softkeys, 283
  - software
    - features, 65
    - how to load, 83, 118
    - loading, 81, 116
    - overview, 81, 114
    - stopping the, 256
  - software revision A.xx.xx
    - printer setup, 260
  - software upgrade
    - loading, 116
  - special display conventions used, 222
  - Specification, 59
  - specifications
    - editing values, 97, 133
    - general description, 97, 133, 254
    - saving, 102, 140
  - specifying channel information
    - general description, 90, 126
  - sq freq/code, 226
  - Squelch Frequency Code, 227
  - SRAM, 308
    - memory cards, 246, 248
  - starting up, 118
  - Stop Test, 284
  - stopping a test, 115, 256
  - stopping the program
    - using Test Execution Conditions, 106, 144, 281
  - structures improperly matched, 294
  - System Information Screen
    - entering conventional channels squelch information, 223
    - entering parameters, 206
    - fields, 138
    - procedures to use with, 138
    - testing multiple channels, 152
    - using General Parameters, 151
    - when to use, 151
-

## T

- Take It, 284
- terminal emulator, 242
  - configuration, 238
  - DataStorm Technologies, Inc. Pro-Comm, 236
  - HP AdvanceLink, 236
- Test Execution Conditions, 106, 144, 281
- Test Function
  - Edit Frequency, 126
  - Edit Parameter, 100, 136
  - Edit Sequence, 122
  - Edit Specifications, 97, 133
  - Procedure Manager, 102, 140
- Test Functions, 120
- test parameters
  - editing values, 252
  - general description, 252
- test procedure, 102
  - saving, 269
- Test Procedure Run Mode, 106, 282
- test results
  - printing using firmware above revision A.14.00, 261
  - printing using firmware below revision A.14.00, 266
  - retrieving from a disk, 242
  - retrieving from a memory card, 234, 250
  - saving, 232
  - where sent, 281
- test set
  - doesn't power up, 301
- test system
  - overall description, 62
- test time, 256
- Test?, 224
- Test\_01 - TX and RX stand-bycurrent drain, 153
- Test\_02 - TX frequencyerror, 155
- Test\_03 - TX output power, 156
- Test\_04 - TXmodulation limiting, 158
- Test\_05 - TXaudio frequency response, 160
- Test\_06 - TX audiodistortion, 163
- Test\_07 - TXmicrophone sensitivity, 165
- Test\_08 - TX FM hum andnoise, 167
- Test\_09 - TXresidual AM hum and noise, 169
- Test\_10 - TXsignaling deviation & freq/code, 171
- Test\_11 - RX hum and noise, 173
- Test\_12 - RX audiodistortion, 175
- Test\_13 - RX frequencyresponse, 177
- Test\_14 - RX usable sensitivity, 180
- Test\_15 - RXconv audio squelch sensitivity, 182
- Test\_16 - RX convsquelch blocking, 184
- Test\_17 - RXsquelch opening with signaling, 186
- Test\_18 - RX audiosensitivity, 188
- Test\_19 - RXconv signal displacement bw, 190
- Test\_20 - RX quick test, 192
- Test\_21 - TX quick test, 196
- Test\_22
  - RT Manual Test, 224
- Test\_22 - RT manual test, 200
- Test\_23 - TXtransient frequency behavior, 204
- testing multiple channels, 152, 226
- testing order
  - securing, 273
- testresults
  - output failures, 281
- Tests, 22, 23, 44, 45
- tests, 308
  - entering a sequence of, 86, 122
  - environment and conditions, 100, 136
  - list of available, 64
  - pausing, 115
  - pausing or stopping, 256
  - required order, 148
  - running, 75, 115
  - stopping, 115
- TESTS (Pass/Fail Limits) screen
  - entering into, 255
- TESTS screen, 308
- TNS Loud, 36, 59
- transmit and receive frequencies, 223
- transmit logininformation
  - parameter, 213
- Transmitter
  - BasicTest, 297
  - Transmitter Current Limiting, 70
  - Transmitter isn't keying, 302
- Troubleshooting, 37
- trunked channel numbers, 90, 126, 223
- trunked transmit or receive channel problems, 289
- TX, 150
- TX audio distn % full rated system dev, parameter 39description, 211
- TX audio distortion, 196
- TX audio freq response roll %, 217
- TX audio freq response start frequency, parameter 40description, 211
- TX audio freq response step frequency, parameter 41description, 211
- TX audio frequency response stop frequency, parameter 42description, 211
- TX audio frequencyresponse, 196
- TX audio level, 201
- TX audio response delta from 6dB/oct, pass/fail limit 24 description, 217
- TX audio response roll >2.5 kHz, pass/fail limit 26description, 217
- TX audiodistortion, pass/fail limit 23 description, 217
- TX Chan Info, 226
- TX conv CT/CDCSS control, parameter 43description, 211
- TX CT Tone, 226
- TX currentdrain, pass/fail limit 29 description, 217
- TX de-key between TX tests, parameter 44description, 212
- TX Deviation, 201
- TX deviation if set and measure mic sens,pass/fail 30 limit description, 218
- TX FM hum and noise, 196
- TX FM hum andnoise, pass/fail limit 31 description, 218
- TX Frequency Error, 201
- TX frequencyerror, pass/fail limit 32 description, 218
- TX mic sens set and measure, parameter 45description, 212
- TX modulation limiting, 196
- TX modulation limiting sweep step freq, parameter 46description, 212

- 
- TX output power, [196](#)
  - TX output power at high supply lowswitch, pass/fail limit [37](#) description, [219](#)
  - TX output power at high supply, pass/fail limit [36](#)description, [219](#)
  - TX output power at low supply low switch,pass/fail limit [39](#) description, [219](#)
  - TX output power at low supply, pass/fail limit [38](#)description, [219](#)
  - TX output power low switch setting, pass/fail limit [40](#)description, [219](#)
  - TX outputpower, pass/fail limit [35](#) description, [218](#)
  - TX Power, [201](#)
  - TX residual AM hum and noise, pass/fail limit [41](#)description, [219](#)
  - TX residual AM hum andnoise, [196](#)
  - TX signaling data, [201](#)
  - TX signalingdeviation & freq/code, [196](#)
  - TX Squelch Type, [226](#)
  - TX trunkeddeviation, high speed, pass/fail limit [43](#) description, [219](#)
  - TX trunkeddeviation, low speed, pass/fail limit [42](#) description, [219](#)
  - TXconv CT/CDCSS deviation, pass/fail limit [27](#)description, [217](#)
  - TXconv CTCSS frequency error, pass/fail limit [28](#)description, [217](#)
  - TXmicrophone sensitivity, pass/fail limit [33](#)description, [218](#)
  - TXmodulation limiting, pass/fail limit [34](#) description, [218](#)
  - TXpower high/low switch, parameter [47](#) description, [212](#)
  - TXuser/system key UUT, parameter [48](#) description, [212](#)
- U**
- upgrade
    - loading software upgrade, [116](#)
  - upgrades,ordering, [63](#)
  - Upper Limit, [36](#), [59](#)
  - USER keys, [283](#), [308](#)
  - UUT, [26](#), [48](#)
- V**
- volume can't be set, [299](#)

**X**

XX secure frequency info, [229](#)  
XXsecure frequency info, parameter 49  
description, [212](#)

**Y**

Yes, [284](#)